

INSTRUCTIONS AND APPLICATIONS

Electronic Voltmeter Type 2409/2416

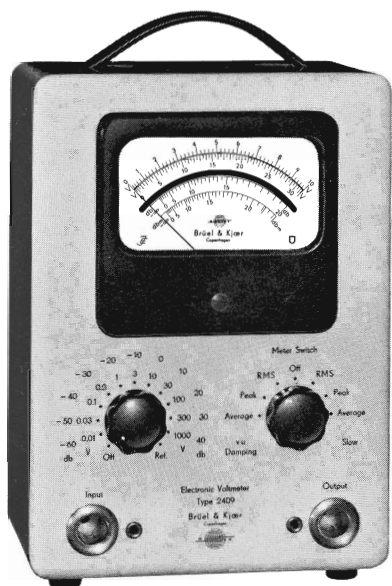

An instrument for the measurement of peak, average absolute, and true R.M.S. values of a.c. voltages in the frequency range 2—20000 c/s. Voltage ranges from 10 mV to 1000 Volt full scale deflection. The high input impedance, low output impedance and accurate attenuator also make this an ideal calibrated amplifier.

Accelerometers
 Acoustic Standing Wave Apparatus
 Artificial Ears
 Artificial Voices
 Audio Frequency Response Tracers
 Audio Frequency Spectrometers
 Audio Frequency Vacuum-Tube Voltmeters
 Automatic A. F. Response and Spectrum Recorders
 Automatic Vibration-Exciter Control Generators
 Band-Pass Filter Sets
 Beat Frequency Oscillators
 Complex Modulus Apparatus
 Condenser Microphones
 Deviation Bridges
 Distortion Measuring Bridges
 Frequency Analyzers
 Frequency Measuring Bridges
 Hearing Aid Test Apparatus
 Heterodyne Voltmeters
 Level Recorders
 Megohmmeters
 Microphone Accessories
 Microphone Amplifiers
 Microphone Calibration Apparatus
 Mobile Laboratories
 Noise Generators
 Noise Limit Indicators
 Pistonphones
 Polar Diagram Recorders
 Preamplifiers
 Precision Sound Level Meters
 Recording Paper
 Strain Gage Apparatus and Accessories
 Surface Roughness Meters
 Variable Frequency Rejection Filters
 VHF-Converters
 Vibration Pick-ups
 Vibration Pick-up Preamplifiers
 Wide Range Vacuum Tube Voltmeters

BRÜEL & KJÆR

Nærum, Denmark . ☎ 80 05 00 . ✉ BRUKJA, Copenhagen . Telex: 5316



Description Contents

Electronic Voltmeter

Type 2409/2416



Contents

Description	3
General	3
Amplifier and Meter Circuit	4
Power Supply	6
Controls and Sockets	7
Operation	9
<i>Procedure</i>	
As Voltmeter	9
As Calibrated Amplifier	9
As Volume Indicator	10
<i>Correct Voltage Levels</i>	
R.M.S. Measurements	10
Average Measurements	11
Peak Measurements	12
Calibrated Amplifier	12
Some Applications	13
Measurement of Impedance, Inductance or Capacitance	13
Checking Amplification and Frequency Response	14
Distortion Measurement	14
Measuring the Q-factor of Inductances	15
Appendix A. VU Measurements	16
Appendix B. Practical Considerations (incl. Transformer feeding)	17
Appendix C. Phase Distortion	20
Appendix D. Measuring Alternating Signals	22
Specification	27

Description

General.

The Electronic Voltmeter Type 2409/2416 is designed for AC voltage measurements in the frequency range 2 Hz (c/s) to 200000 Hz (c/s), with voltage ranges from 10 mV full scale deflection to 1000 volts full scale deflection in 10 dB steps. It is available in a portable form, illustrated on the front cover of this book (Type 2409) and also as Type 2416, shown below, which is suitable for mounting in a standard 19" rack.

Types 2409 and 2416 are electrically identical, so for the sake of brevity, the type number 2409 will be used in most parts of this manual as being representative of both forms of the voltmeter.



Fig. 1. Electronic Voltmeter Type 2416.

A two stage amplifier is followed by rectifying circuits for RMS, average, and peak measurements, and a moving coil meter. Two different degrees of damping can be selected for the meter so that clear and accurate readings can be obtained throughout the frequency range. The amplifier is provided with an output jack making it possible to use the instrument as a calibrated amplifier having a maximum gain of 60 dB (i.e. 1000 times).

Amplifier and Meter Circuit.

The screened input socket is connected to an attenuator circuit containing 10 steps of 10 dB. The eleven measuring ranges are designed to give full deflection for the following voltages: 10 mV, 31.5 mV, 100 mV, 315 mV, 1 V,

3.15 V, 10 V, 31.5 V, 100 V, 315 V, and 1000 V. The attenuator is divided into two sections, one of which contains two steps of 40 dB, the other one containing three steps of 10 dB. Both sections are operated by means of a single switch on the front plate of the apparatus.

A cathode follower stage is inserted between the two attenuator sections in order to obtain a high input impedance. The input impedance is 10 M Ω parallel to 20 pF. A series capacitor in the grid circuit of the cathode follower protects the Voltmeter against DC voltages.

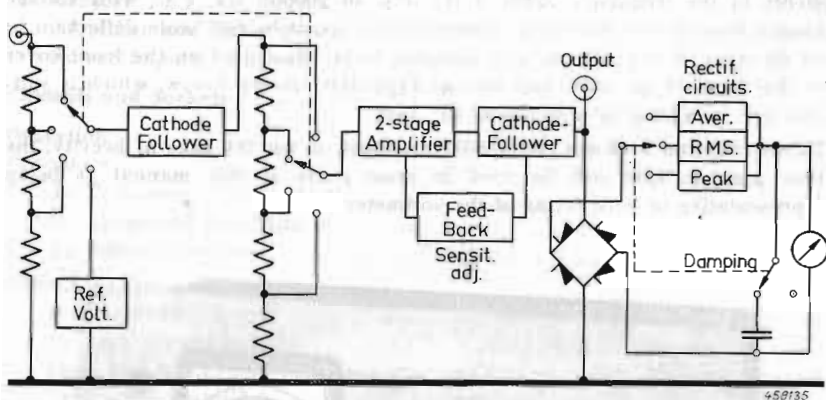

Fig. 2. Block diagram of Type 2409.

From the attenuator the signal is fed to a two stage amplifier, consisting of a triode and a pentode, and followed by a cathode follower providing a low output impedance for the meter circuit as well as the output jack. The amplifier is R-C coupled and by means of a potentiometer the amount of negative feedback, and thereby the sensitivity of the instrument, can be varied. The sensitivity potentiometer is accessible through a hole in the back

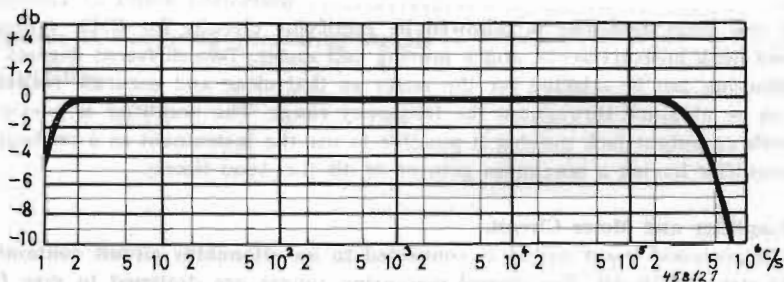

Fig. 3. Typical frequency response of the Electronic Voltmeter Type 2409.

plate of the 2409 or through the front plate of the 2416. It is adjusted with the aid of a screwdriver.

A second feedback circuit gives the voltmeter a sharp cut-off just below 2 Hz (c/s). The signal from the output cathode follower is fed to the meter circuit and also to an output jack making it possible to use the instrument as an amplifier. The maximum amplification is 1000, i.e. 60 dB, and the output impedance is approximately 50 ohms in series with 25 μ F. Output voltages up to 30 volts are available without noticeable distortion (less than 1 %). As the meter has full scale deflection for 10 volts output, the METER SWITCH may be turned to its "Off" position when output voltages higher than 10 volts are desired.

The meter circuit consists of a full wave bridge rectifier, various rectifying circuits and a moving coil meter.

By means of the METER SWITCH it is possible to choose between the three different measuring characteristics, which provide for readings of the following quantities (explained in Appendix D):

True R.M.S.
Peak,
or Average Absolute

values of the alternating input voltage.

The true R.M.S. value of signals with crest factors up to 5 (14 dB) can be measured to within $\pm 6\%$ (± 0.5 dB) of the theoretically correct value.

The peak rectifier circuit is designed to measure *half* the peak-to-peak value of the input signal. This should be borne in mind when peak measurements are carried out on unsymmetrically shaped signals.

Two different meter damping characteristics can be selected. The one normally used, low damping, is in accordance with the American Standard for "vu" measurements (Appendix A). The other provides heavier damping for low frequency work, below 40 Hz (c/s), where the pointer would otherwise fluctuate or the indicated value would be too low.

The moving coil meter itself is illuminated and the scale is graduated in volts from 0 to 10 V and from 0 to 31.5 V as well as in dB from 0 to 20 dB re. 1 volt and furthermore in dbm, which is here defined as dB re. 0.775 volts (1 mW in 600 ohms).

In order to check and correct the sensitivity of the instrument a reference circuit is built in. When the input attenuator knob on the front plate is turned to its extreme clockwise position, a reference voltage is fed to the grid of the input cathode follower. The reference voltage is developed across a zener-diode, whereby the waveform becomes an approximated square wave. As the wave form is not a pure square wave, the deflection on the meter will be different for different positions of the METER SWITCH. The red mark (8 V) on the scale, which is used for reference, is the value to which the meter pointer should deflect, when the METER SWITCH is in position "R.M.S.". The meter damping has no influence on the reference point.

Power Supply.

The Electronic Voltmeter can be operated from power lines supplying 100 — 115 — 127 — 150 — 220 or 240 volts and at frequencies from 50 to 400 Hz (c/s) not DC. The power consumption is about 28 watts.

The instrument is protected by a fuse in the primary side of the power transformer. The fuse holder is combined with the voltage selector at the back of the instrument. To set the voltmeter to the correct supply voltage, unscrew and withdraw the cartridge fuse and then, with the aid of a coin, turn the selector until the white bar is in the desired position. Replace the fuse.

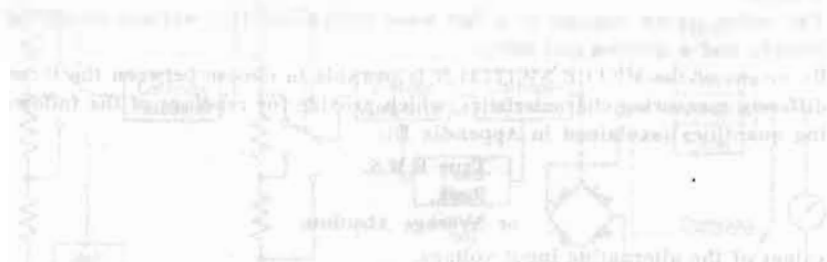

The power supply section of the Electronic Voltmeter is designed to operate from power lines supplying 100 — 115 — 127 — 150 — 220 or 240 volts and at frequencies from 50 to 400 Hz (c/s) not DC. The power consumption is about 28 watts.

The instrument is protected by a fuse in the primary side of the power transformer. The fuse holder is combined with the voltage selector at the back of the instrument. To set the voltmeter to the correct supply voltage, unscrew and withdraw the cartridge fuse and then, with the aid of a coin, turn the selector until the white bar is in the desired position. Replace the fuse.

The power supply section of the Electronic Voltmeter is designed to operate from power lines supplying 100 — 115 — 127 — 150 — 220 or 240 volts and at frequencies from 50 to 400 Hz (c/s) not DC. The power consumption is about 28 watts.

The instrument is protected by a fuse in the primary side of the power transformer. The fuse holder is combined with the voltage selector at the back of the instrument. To set the voltmeter to the correct supply voltage, unscrew and withdraw the cartridge fuse and then, with the aid of a coin, turn the selector until the white bar is in the desired position. Replace the fuse.

The power supply section of the Electronic Voltmeter is designed to operate from power lines supplying 100 — 115 — 127 — 150 — 220 or 240 volts and at frequencies from 50 to 400 Hz (c/s) not DC. The power consumption is about 28 watts.

Control Knobs, Sockets etc.

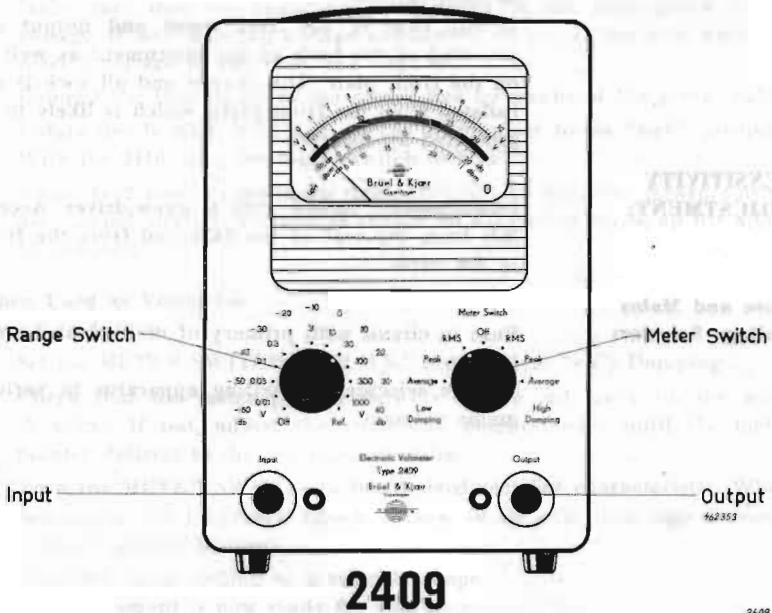

Fig. 4. Front View of the Electronic Voltmeter Type 2409.

RANGE SWITCH:

Calibrated attenuator: 10 dB steps. It is also the On/Off control for the 2409, but not for the 2416 which has a separate toggle switch.

METER SWITCH:

For selection of the three different meter indicating properties

“Average”

“Peak” (half peak to peak)

“R.M.S.”

The three positions to the left give the smaller damping of the indicating meter designated either

"Low Damping" or "vu Damping".

The positions to the right give the higher damping or "Slow" response. In the middle position "Off.", the meter circuit is disconnected.

INPUT and OUTPUT:

The screened sockets take standard B & K coaxial plugs JP 0018. The chassis side is also connected to 4 mm sockets so that pairs of banana plugs can be used instead.

In the case of the 2416 input and output are provided at the back of the instrument as well as on the front plate. The chassis and all sockets are isolated from the front plate, which is likely to be grounded by the rack.

**SENSITIVITY
ADJUSTMENT:**

Potentiometer turned with a screw-driver. Accessible from the rear of the 2409 and from the front of the 2416.

**Fuse and Mains
Voltage Selector:**

Fuse in circuit with primary of mains transformer (1 amp.).

Voltage selector, for setting apparatus to various mains voltages.

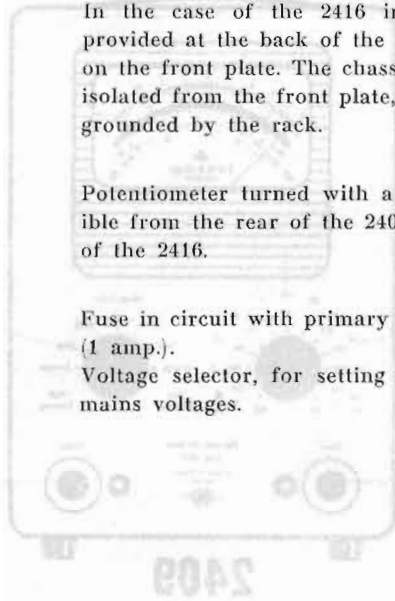

Fig. 4. Front view of the Electronic Voltmeter Type 2409.

Calibrated attenuator to its right. It is also the output control for the 2409, but not for the 2416 which has a separate output switch.

For selection of the three different meter indications.

"Average"
"Peak" (half peak to peak)
"R.M.S."

The three positions to the left give the damping of the indicating meter designated either

WAVE SWITCH

METER SWITCH

Operation

Procedure.

1. Make sure that the apparatus is adjusted to the appropriate mains voltage. If not, turn the voltage adjustment switch at the back until the correct voltage is indicated (see page 6).
2. Connect the instrument to the power line by means of the power cable.
3. Rotate the RANGE SWITCH on the front plate to its "Ref." position. With the 2416, flick the toggle switch to "On".
4. Allow 1—2 minutes warm-up time. (When very accurate measurements are carried out, the instrument should be allowed to warm-up for about 15 minutes).

When Used as Voltmeter.

Items 1 to 4, then

5. Set the METER SWITCH to "R.M.S." — "Low (or "vu") Damping".
6. Check that the meter pointer deflects to the red mark on the scale (8 volts). If not, adjust the sensitivity potentiometer until the meter pointer deflects to the red mark (8 volts).
7. Turn the METER SWITCH to the desired rectifier characteristic. When measuring low frequency signals (below 40 Hz (c/s)) the high damping ("Slow") should be used.
8. Turn the range switch to a suitable range.

The instrument is now ready for use.

Unlike ordinary passive voltmeters the input impedance is almost unaffected by the range setting, but note that the impedance between the points under investigation should be small compared with 10 M Ω , i.e. 100 k Ω or less.

Some of the complications which may arise are discussed in Appendices B and C.

When Used as a Calibrated Amplifier.

Items 1 to 4, then

9. Connect the centre of the input socket to the centre of the output socket via a short lead.
10. Set the RANGE SWITCH to 0 dB.
11. Rotate the sensitivity adjustment until the amplifier just starts oscillating. This is indicated on the meter as the point where the meter pointer suddenly moves from a position slightly above zero to full deflection

12. After removing the short lead, the amplifier is ready for use and the attenuator scale can be used for reference, i.e. when the attenuator switch is set to -10 dB, the amplification is 10 dB (or 3.2 times), when the attenuator switch is set to -20 dB, the amplification is 20 dB (10 times) etc.

N.B. Do not forget to set up the instrument as a voltmeter before using it again for that purpose.

The source feeding this amplifier should have an impedance of less than $100\text{ k}\Omega$, and the amplifier output should look into an impedance of at least $5\text{ k}\Omega$, preferably resistive. The load impedance should normally be more than $50\text{ k}\Omega$ if the meter is in circuit.

When Used as a Volume Indicator.

Items 1 to 4, then

13. Switch the METER SWITCH to "vu damping" (low damping), "Average", and the attenuator switch to its "Ref." position.
14. Adjust the sensitivity potentiometer until the meter pointer deflects to the reference mark to the "dbm" scale.
15. Turn the range switch to a suitable range and make the measurements, consulting Appendix A.

N.B. All vu measurements must be made with the meter switch in the "Average" position.

Correct Voltage Levels.

The problem of characterizing the magnitude of a varying signal by the most informative figure is not as simple as one would suppose. To derive the maximum benefit from this versatile instrument the terms "R.M.S.", "Average", and "Peak" should be fully understood and to assist those who are not clear, the quantities are explained in an appendix.

The following practical points must be borne in mind:

R.M.S. Measurements.

The circuit is developed to measure the R.M.S. value of signals with crest factors f_c as high as 5, which as exemplified by Fig. 5 is adequate even for most pulse work within the frequency range of the instrument.

$$f_c = \frac{V_{\text{peak}}}{V_{\text{rms}}} \approx 5$$

However, the maximum current which can be drawn from the amplifier is 8 mA, and since the rectifier circuit represents a load of $5\text{ k}\Omega$, the amplifier peak output voltage should not exceed

$$5\text{ k}\Omega \times 8\text{ mA} = 40\text{ volts.}$$

Therefore the highest deflection for R.M.S. values of the meter pointer when measuring signals with crest factors 5, should not exceed

$$V_{\text{rms}} = \frac{V_{\text{peak}}}{f_c} = \frac{40}{5} = 8 \text{ Volts}$$

For full deflection the crest factor f_c should not exceed:—

$$f_c = \frac{40}{10} = 4$$

since the meter itself has 10 Volts full scale deflection regardless of range setting.

The high frequency limit of the instrument may be important when measuring signals with many significant harmonics.

Average Measurements.

Care should be taken not to overdrive the amplifiers when measuring the average value of a complex signal which has high peaks. It is therefore necessary to know the highest peaks, positive or negative, which occur in the measured signal. By using the two factors, crest factor f_c and form factor f_f ,

$$f_c = \frac{V_{\text{peak}}}{V_{\text{rms}}} \quad f_f = \frac{V_{\text{rms}}}{V_{\text{average}}}$$

the peak value of the signal may be calculated*), provided the average value (read on the meter) and the two factors are known.

$$V_{\text{peak}} = f_c \times f_f \times V_{\text{average}}$$

As the 40 Volts peak should not be exceeded, when the meter pointer gives full deflection for average value, the highest permissible value for

$$f_c \times f_f = \frac{40}{10} = 4.$$

If the meter pointer has not full deflection, the product $f_c \times f_f$ could be proportionately higher.

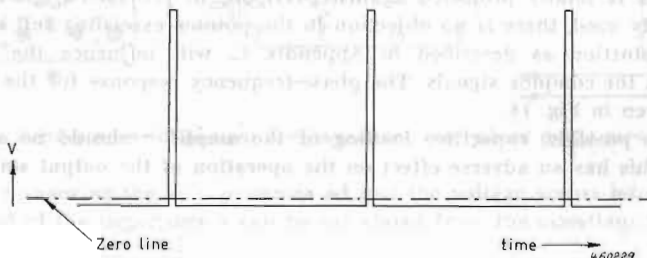

Fig. 5. Example of unsymmetrical signal with a crest factor of approximately 5.

*) The objection to taking a simple peak measurement (q.v.) here is that it is the half peak-to-peak value which is read.

When measuring signals with many significant harmonics, i.e. pulses, the amplifier limiting at high frequency should be remembered.

Peak Measurements.

The meter deflection corresponds to the half peak-to-peak value of the signal. This should be taken into account when the input signal is not symmetrical, because the peak value read on the meter is not then the maximum that occurs.

The peak meter is calibrated for signals of crest factor 1.41. With signals of other crest factors there will be small deviations — within the specified 2 % tolerance —, as mentioned in Appendix D.

When measuring complex signals, not only must the attenuation of harmonics outside the frequency range be considered as with R.M.S. and Average readings, but also phase distortion within the frequency range may be significant. See Appendix C.

Calibrated Amplifier.

As stated earlier, when the meter networks are in circuit the amplifier output voltage must not exceed 40 volts peak owing to current limiting. These networks can be disconnected by turning the METER SWITCH to "Off", but even assuming that there is then no load on the amplifier, the peak output should not be more than 45 volts or overdriving will result. Keeping distortion below 1 %, the maximum R.M.S. value of a sine wave (crest factor 1.41) which the amplifier can handle is about 30 volts, or somewhat less if the meter is in circuit.

The maximum permissible output current is 8 mA, so even when the meter circuits are switched out, any external impedance across the output must be greater than 5 k Ω or the full voltage range cannot be used.

When the meter is in use the external impedance must be 50 k Ω or more if high peak voltages are present.

The meter is totally protected against overload, so provided the amplifier is correctly used, there is no objection to the pointer exceeding full scale.

Phase distortion as described in Appendix C, will influence the output waveform for complex signals. The phase-frequency response for the amplifier is given in Fig. 14.

As far as possible, capacitive loading of the amplifier should be avoided because this has an adverse effect on the operation of the output stage.

Some Applications

In addition to straightforward current measurements, for which external shunts are required, and voltage measurements, this versatile instrument can be used in conjunction with an oscillator to form an excellent laboratory test system. The B & K Beat Frequency Oscillators

Type 1013 200 Hz (c/s)—200 kHz (kc/s),

Type 1022 20 Hz (c/s)—20 kHz (kc/s),

Type 1017 2 Hz (c/s)—2 kHz (kc/s),

between them cover the frequency range of the 2409 and make possible the measurement of, for example, the following:

Impedance, Inductance, or Capacitance.

For the measurement of the numerical value of the impedance as well as the phase angle, the bridge arrangement shown in Fig. 6 may be employed. Using the Electronic Voltmeter for indication, the resistor R is adjusted till the voltage across ab is equal to the voltage across ac. Then the numerical value of the unknown impedance, z, is equal to the resistance R.

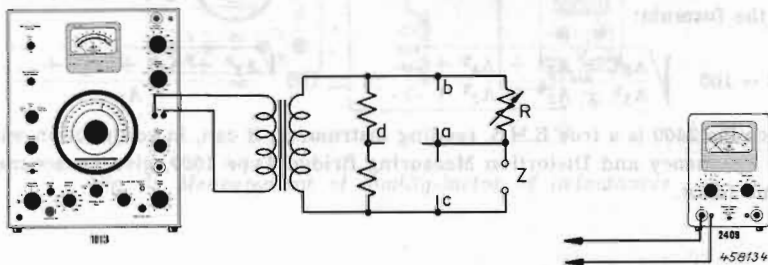

Fig. 6. Measuring arrangement for impedance and phase angle measurements.

When measuring the voltage across ad and the voltage across bd, the phase angle ϕ of the impedance z can be calculated from the equation: $\tan \phi/2 =$

$$\frac{ad}{bd}$$

If there is a condenser at Z, its capacitance $C = \frac{1}{2\pi f R}$

where f = frequency in c/s. If Z is due to an inductance, $L = \frac{R}{2\pi f}$.

Amplification and Frequency Response.

The frequency response of a four-terminal network can be checked when an arrangement as shown in Fig. 7 is used. The resistors R_i and R_o should match the input and output impedance of the network under test.

By reading the two values off the voltmeter dB-scale in connection with the dB-scale of the calibrated attenuator, the input and output voltage is expressed in dB above 1 volt. By subtracting the input value from the output value, the amplification (or attenuation) is found directly in dB.

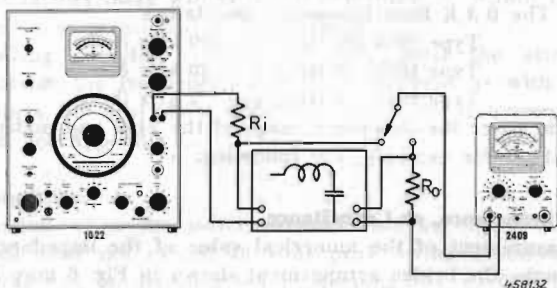

Fig. 7. Measurement of amplification and frequency response of amplifiers, filters etc.

Distortion.

The non-linear distortion in four-terminal networks is normally expressed by the formula:

$$d = 100 \sqrt{\frac{A_2^2 + A_3^2 + A_4^2 + \dots}{A_1^2 + A_2^2 + A_3^2 + \dots}} \% \approx 100 \frac{\sqrt{A_2^2 + A_3^2 + A_4^2 + \dots}}{A_1}$$

Since the 2409 is a true R.M.S. reading instrument, it can, in conjunction with the Frequency and Distortion Measuring Bridge Type 1607, give an accurate value for d .

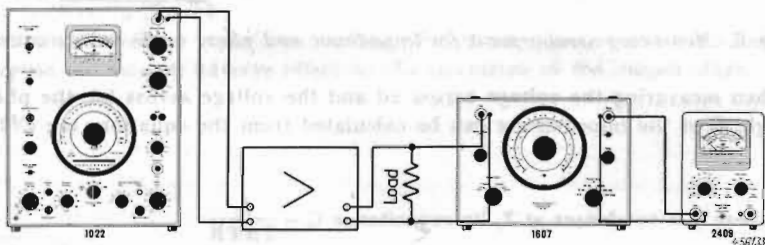

Fig. 8. Measuring arrangement for distortion measurements.

The 1607 is basically a variable blocking network, with which any frequency in the range 20 Hz (c/s) to 20000 Hz (c/s) can be attenuated by more than 80 dB.

The complete output signal from the network under test should first be fed to the Electronic Voltmeter Type 2409, and the amplification adjusted until the meter pointer gives maximum deflection on the meter (10 on scale). The measuring frequency is then rejected by the 1607, and the reading on the Electronic Voltmeter is now the factor $d\%$. Note: The METER SWITCH on Type 2409 must be switched to measure the RMS value of the signal.

The Quality Factor of Inductances.

Fig. 9 shows how the Q of a self-inductance can be measured with the Electronic Voltmeter Type 2409. With the aid of a low-loss capacitor C the measuring circuit is brought into resonance at the measuring frequency used. The ratio of the two voltages, measured in the two positions of the switch, is the desired Q-value; $Q = \frac{V_2}{V_1}$. It is a condition that $Q \times \frac{1}{2\pi f C} \leq 10 M\Omega$.

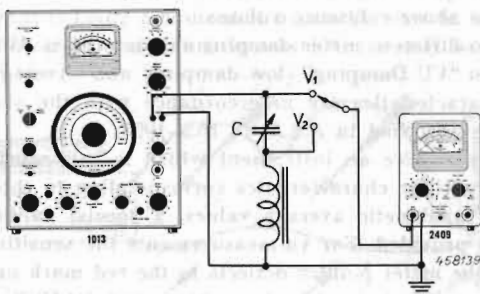

Fig. 9. Measurement of quality-factor of inductances.

Appendix A

VU Measurements.

The Electronic Voltmeter Type 2409 can be used as a "volume unit" (vu) indicator. "Volume", which is defined as "the dynamic magnitude of complex audio-frequency electrical waves such as occur in speech and music", can be measured by reading off the dbm-scale directly. With the range switch in position 0 dB/10 V, a deflection of 0 dbm corresponds to 0 vu, which is equal to a power level of 1 mWatt developed in a resistance of 600 ohms, the voltage reference thereby being 0.775 volts.

When the range switch is turned to any other position, the indicated attenuation in dB should be added to the value read off on the meter dbm-scale in order to give the level in vu. The level which for this instrument can range from -60 to +62 dbm, is numerically equal to the number of decibels which express the ratio of the magnitude of the waves to the magnitude of the above reference volume.

The 2409 has two different meter damping characteristics. When the METER SWITCH is set to "VU Damping" (low damping) and "Average", the damping and rectifier characteristics are in accordance with the standards for vu-measurements as specified in A.S.A. C. 16.5.-1954.

As the standards require an instrument which is calibrated in RMS-values and which has rectifier characteristics corresponding to those used for the measurement of arithmetic average values, a special calibration mark on the dbm-scale is provided. For vu-measurements the sensitivity should thus be adjusted till the meter pointer deflects to the red mark on the dbm-scale, when the range switch is in its ref. position, and METER SWITCH set to "Average", vu.

The correct vu reading is determined as the "greatest deflection occurring in a period of about a minute for program waves, or a shorter period (e.g. 5 to 10 seconds) for message telephone speech waves, excluding not more than one or two occasional deflections of unusual amplitude".

To measure the power level of a transmission line the instrument is connected directly across the line, and the level can be read off the dbm-scale, provided that the characteristic impedance of the line is 600 ohms*).

Often the instrument is used for measurements on lines with an impedance different from 600 ohms. In such cases the reading obtained on the dbm-scale no longer represents the power level in dbm, but is the voltage level in dB above 0.775 volts, and should be referred to as "dB re. 0.775 volts".

*) For symmetrical input, use Transformer TI 0001, see page 18.

Appendix B

Practical Considerations.

The use of the voltmeter is normally perfectly straightforward, especially at "everyday" voltage levels, but minor difficulties may arise in certain applications. It is impossible to generalise and to solve all such snags with the help of written instructions, but the user may have to consider some of the following points.

Grounds and Ground-Loops.

In common with most mains operated equipment, there is a small capacitive path to ground, which may result in a certain amount of noise pick-up. This pick-up can be greatly reduced by grounding the chassis side of the input directly. However, remember that by doing this a ground loop can be formed via other grounds in the system being investigated.

To be sure of what is being measured it is usually wise to use two test leads and not to rely on a ground return in which there may be injected E.M.F.s

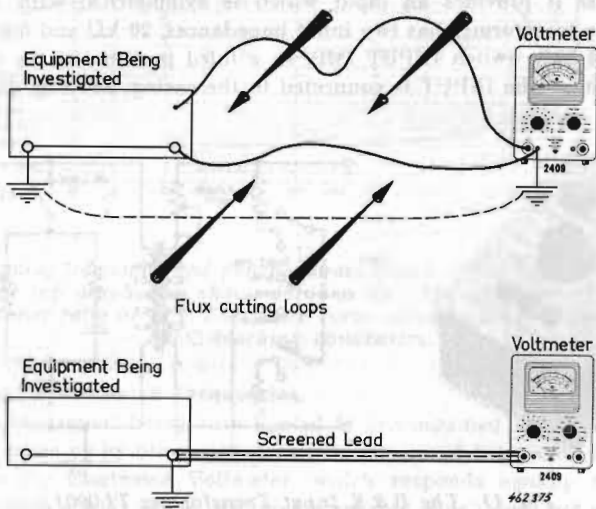

Fig. 10. When measuring small signals, use screened leads (bottom picture) and try to avoid ground loops. An arrangement such as that in the top picture is inherently un-sound but is particularly bad practice when using a high impedance instrument like the 2409/2416.

from unexpected sources. By altering the position of the grounds, and being careful in the lay-out of leads, using screened cable wherever possible, an optimal solution can be found.

Do not forget that the steel case of the 2409 (not the 2416) is connected directly to the chassis, and although the instrument stands on rubber feet, it is possible to inadvertently introduce an extra ground path if the case is close to a metal structure.

This last fact is important, not only from the measurement, but also from the safety point of view when checking the voltage across two terminals which are both at some D.C. potential with respect to ground. The 2416 presents no difficulties here, but when investigating, for example, the anode circuits of a power amplifier, both test leads for a 2409 should be in series with a capacitor having an impedance which is very small compared with $10\text{ M}\Omega$ at the frequency concerned.

Transformers.

Often one solution to ground loop problems is to use an isolating transformer, an accessory which is essential in measuring arrangements having incompatible grounding requirements, for instance bridge circuits such as that shown in Fig. 6.

The B & K Input Transformer TI 0001 is particularly useful in conjunction with the Electronic Voltmeter, not only for ordinary isolation purposes but also because it provides an input which is symmetrical with respect to ground. The transformer has two input impedances, $20\text{ k}\Omega$ and 600Ω , which are selected by a switch INPUT IMP. In a third position of the switch the middle point of the INPUT is connected to the casing. See Fig. 11.

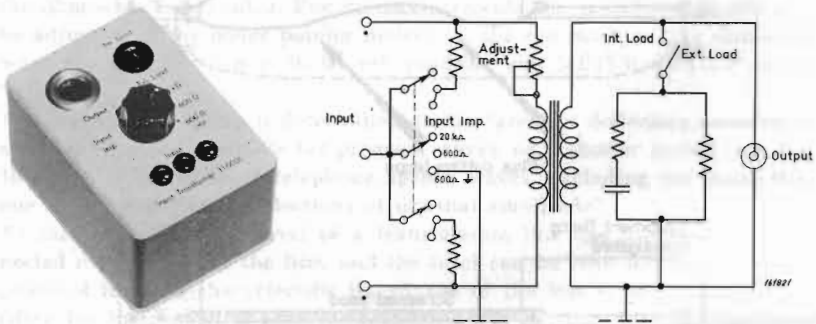

Fig. 11. The B & K Input Transformer TI 0001.

To ensure correct loading ($15\text{--}25\text{ k}\Omega$) on the transformer secondary, the "Internal Load" must be switched in and the special screened cable AO 0018, which has a capacity of 26 pF , should form the link to the voltmeter.

If there is a DC component in the signal to be measured, protect the primary of the transformer with a series capacitor of about $1 \mu\text{F}$ in the input leads. (See Fig. 13).

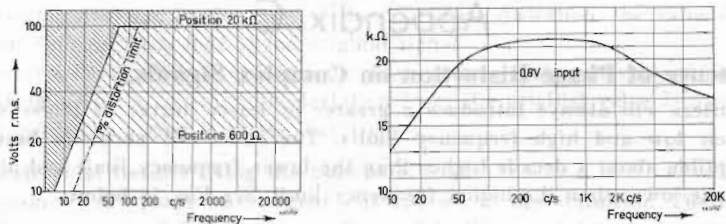

Fig. 12.

- a) Maximum input voltage to the Input Transformer T10001. At low frequencies the limit is $V_{m.a.} = 1.6 f$ (or $0.8 f$ for less than 1% distortion).
- b) Input impedance of the Transformer T10001 at various frequencies. (Typical curve for 0.8 V input voltage).

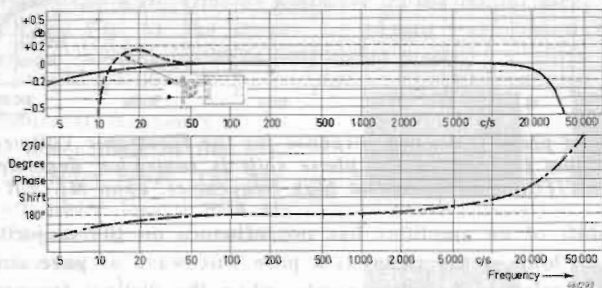

Fig. 13. Typical frequency and phase characteristics of the Input Transformer T10001. The top graph also shows (broken line) the tolerance of $\pm 2\%$ on the transformer ratio of 1 : 1. The phase curve refers to a direct input with no D.C.-blocking condensers.

Suppression of Unwanted Frequencies.

Sometimes the signal being investigated is accompanied by a considerable amount of noise or by other signals which are not of immediate interest. In such cases the Electronic Voltmeter, which responds equally to all frequencies within a wide range, will give a reading which does not specifically refer to the problem being studied. It is then necessary to add an external filter on the input which, in the case of a simple passive network, will have a much lower input impedance than the Voltmeter itself, if there is to be no adverse effect on reading accuracy.

Appendix C

Influence of Phase Distortion on Complex Signals.

Amplifiers will always introduce a greater or lesser degree of phase shift at their low and high frequency limits. The shift will normally become perceptible about a decade higher than the lower frequency limit and about a decade lower than the higher frequency limit. See Fig. 14 below.

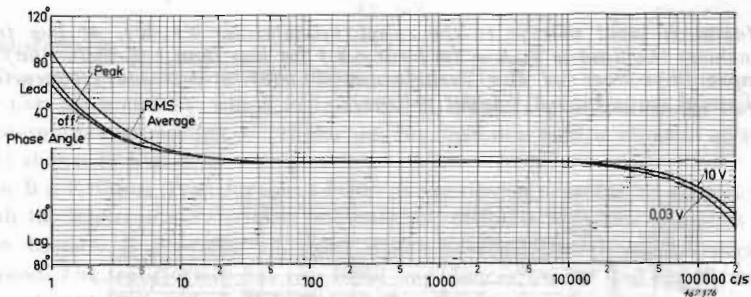

Fig. 14. Typical phase-frequency response for the Electronic Voltmeter Type 2409/2416. At low frequencies the phase shift is somewhat dependent upon the METER SWITCH setting, and at high frequencies, upon METER RANGE.

The phase shift of an amplifier has no influence on the majority of its applications as long as the signal is a pure sine wave or pure sine waves with no phase relation, in other words, when the distinct frequencies do not comprise the harmonics of a signal. If such a signal is rectified and applied to an indicating circuit measuring true R.M.S., Average, or half Peak-to-peak values of the signal, any possible phase distortion will have no influence on the measured result. On the other hand, if the applied signal has a complex periodic character and thus contains harmonics with a certain phase relationship (as is the case, for example, with a square-wave or triangular signal), the signal shape will be distorted when treated in an amplifier with frequency-dependent phase shift. However, the number of harmonics and their original amplitudes are unchanged in the phase distorted signal, presuming that the amplitude-frequency characteristic of the circuit is practically straight in the range of the signal frequency components. The following should be noted when a signal containing harmonics is applied to a rectifier circuit which detects true R.M.S., average, or half peak-to-peak:—

Measuring R.M.S.: This is by far the most important in the majority of investigations. When using this characteristic of the indicating circuit, the phase relationship of the different components in the signal has no influence. **Therefore, by measuring a phase distorted signal with an R.M.S. indicating circuit, the same value will be read as for the undistorted signal.**

Measuring Average: In this case, if there is phase distortion, the value of the signal deviates from that of the original signal.

Measuring Peak: When utilizing the half peak-to-peak property of the indicating circuit a considerable deviation from the original value is measurable when the signal is phase distorted.

Experimental Results Using the 2409/2416.

A symmetrical square wave signal was applied to the voltmeter. The actual Peak, Average, and R.M.S. value (all equal in this case) was known so that any deviations in meter reading could be seen immediately.

As expected, the R.M.S. indication remained constant except at high fundamental frequencies of the square wave, where the harmonics lay outside the amplifier's frequency range and were attenuated. The Average reading was affected by up to 25 % (1 or 2 dB) at the extreme ends of the frequency range, but the Peak reading doubled (deviated by about 6 dB) at 2 Hz (c/s).

Fig. 15 shows the waveforms as measured at the output jack. As would be expected from Fig. 14, the shapes are almost independent of Voltmeter knob settings. (Assuming satisfactory signal levels).

a) Fundamental frequency 2 Hz (c/s), the lower limit of the voltmeter's frequency range. The harmonics are phase lagged with respect to the fundamental, causing phase distortion.

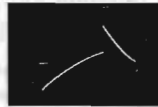

a



b

b) 50 Hz (c/s). Very little distortion.



c



d

c) 1 kHz (kc/s). Undistorted.

d) 100 kHz (kc/s). The harmonics are phase shifted with respect to the fundamental and also attenuated somewhat.



e

e) 200 kHz (kc/s), the upper frequency limit for the voltmeter. The harmonics are almost completely rejected because of the high frequency cut-off, leaving only the fundamental sine wave.

Fig. 15. Oscilloscope photographs of the waveform at the output jack when a square wave is applied to the amplifier input.

a) 2 Hz (c/s). b) 50 Hz (c/s).

c) 1 kHz (kc/s). d) 100 kHz (kc/s).

e) 200 kHz (kc/s).

Appendix D

Measuring Alternating Signals.

Measurements of the instantaneous values of an alternating voltage are not very instructive and in any case are usually impossible to obtain. A measuring instrument must be designed to take an "overall view", smoothing out the waveform variations, but yet it must respond to changes in the effective value of the signal. The instrument in effect samples the levels of a varying signal $V(t)$ during a time interval T (between t_1 and t_2) which is sufficiently long so that if a slightly different value of T is used, the same meter reading results. At the same time, T is short enough to allow the pointer to respond to changes in overall level.

The three quantities which are most commonly used to characterise the magnitude of such a signal are

Peak Value,

$$V_p = V \text{ max. } (t) \text{ during } T; \dots\dots\dots 1.$$

Average Absolute Value,

$$V_A = \frac{1}{T} \int_{t_1}^{t_2} |V(t)| dt, \dots\dots\dots 2.$$

referred to as "Average" value;

or **RMS Value,**

$$V_{RMS} = \sqrt{\frac{1}{T} \int_{t_1}^{t_2} [V(t)]^2 dt}, \dots\dots\dots 3.$$

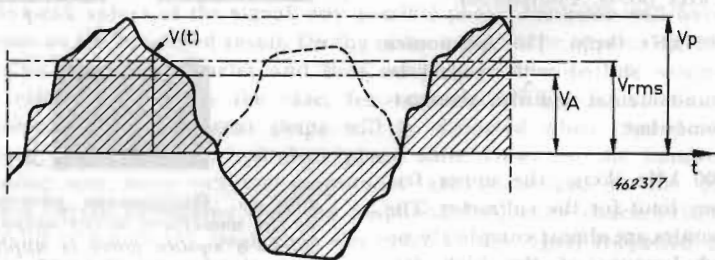

Fig. 16. Example of a periodic signal with indication of the Peak, R.M.S., and Average values of the voltage.

Which of these should be used, V_p , V_A or V_{RMS} , depends upon circumstances. The peak value is particularly useful when dealing with limiting in non-linear circuits, and the average value is of interest in many investigations, especially those concerned with mechanical forces, perhaps of electromagnetic origin. The R.M.S. value is the most commonly used, in fact it is the quantity normally given unless otherwise stated. It is of great significance because the power dissipated in linear systems depends directly on this value.

Fig. 16 indicates all these quantities for a general waveform.

The crest factor is defined as:

$$f_c = \frac{V_{peak}}{V_{rms}}$$

and the form factor:

$$f_t = \frac{V_{rms}}{V_{average}}$$

From these expressions it is readily seen that the crest factor of sharp periodic pulses must be high, while the crest factor, as well as the form factor for an ideal square-wave is exactly 1. It is thus possible, in some cases, by measuring the crest factor and the form factor to obtain a rough picture of the signal wave shape.

Since the R.M.S. value is the quantity which is usually required, it has become common practice to calibrate meters to indicate R.M.S., even though the instrument actually measures the average or peak value. This is justified for sinusoidal signals because the crest factor and the form factor have fixed values, but if an R.M.S. indication is wanted for other waveforms

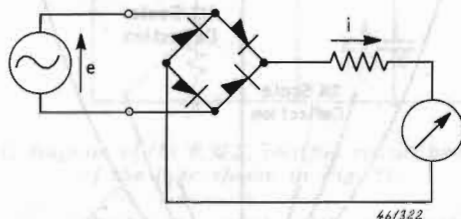

Fig. 17. Schematic diagram of Average rectifier.

where f_c and f_t vary, the instrument must really measure RMS values.

The Electronic Voltmeter Type 2409/2416 does give a true R.M.S. indication as well as making Average and Peak measurements.

The Average rectifier circuit is shown schematically in Fig. 17. The operation of the average circuit is understood most easily by considering the mathematical expression for the components of any rectified waveform. The

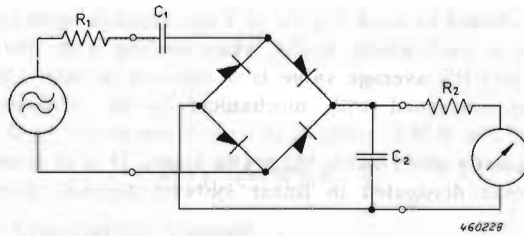

Fig. 18. The circuit used to obtain Peak indication.

meter itself is insensitive to all the alternating components, but responds to the steady component, which is exactly as given in equation 2.

To enable the full-wave Peak rectifier to offer maximum accuracy with many different unsymmetrical signals, the amplifier output is fed to the bridge via a capacitor C_1 . (See Fig. 18). By doing this, C_2 always sees a virtually symmetrical signal (rectified), and is thus charged up*) to half the peak-to-peak voltage. C_2 can only discharge through the meter movement and the time constant R_2C_2 is long compared with the signal period. The

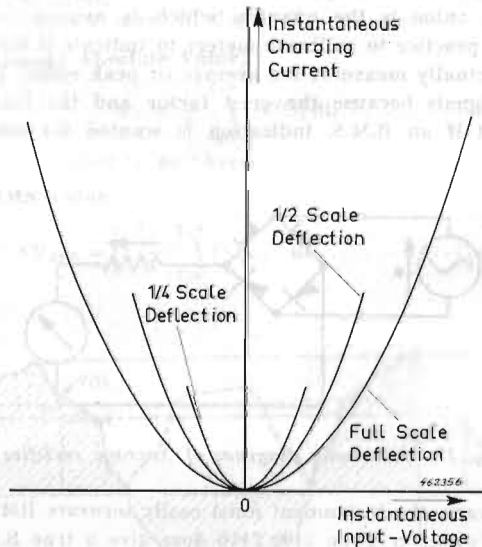

Fig. 19. Ideal R.M.S. rectifier characteristics.

*) In the case of rectangular pulses, the whole cycle is useful and there is no "dead-time". Dead-time has an adverse effect on accuracy.

reading error is a function of the signal waveform and of the ratio between R_2 and R_1 . Ideally, R_2 should be infinite, and R_1 zero. In practice, R_2/R_1 is large enough to ensure that Peak readings on periodic waves are within 2%, even for crest factors of 5, the instrument being calibrated at one crest factor only (1.41).

The R.M.S. arrangement is similar to the Peak circuit in as much as the meter itself measures the current drain from a condenser which has the charge so lost replenished from the signal feeding the rectifier. The difference lies in the special manner in which the condenser is charged by this input. It can be shown that for a certain R.M.S. value, i.e. a fixed meter reading, the instantaneous input voltage (which varies from zero to perhaps several times the R.M.S. voltage) should theoretically have a parabolic relationship with the charging current. Furthermore, there should be a particular parabola for each R.M.S. reading: Fig. 19 gives some examples.

This form of characteristic is realised in practice by the insertion of a non-linear element (Figs. 20 and 21).

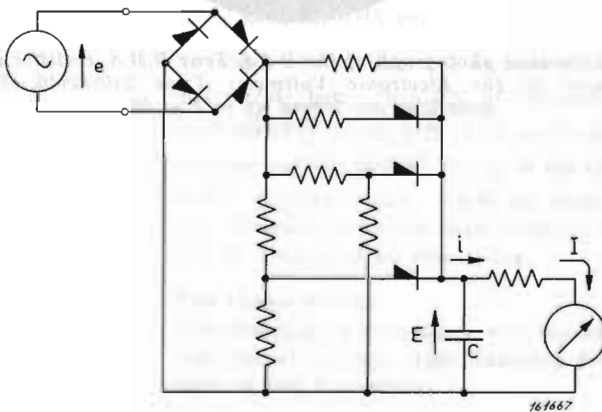

Fig. 20. Schematic diagram of the R.M.S. rectifier circuit having characteristics of the type shown in Fig. 21.

This circuit can correctly handle signals with crest factors as high as 5, which covers most waveforms likely to be met in practice, including pulses as "spikey" as those shown in Fig. 5, and also random noise. Theoretically, random noise has an infinite crest factor, but almost no error is introduced by taking the crest factor to be 3, because the probability of occurrence of the higher peaks is so small that their energy contribution is insignificant. For Average, Peak, or R.M.S. measurements at lower frequencies it is important to select the correct meter circuit time constant, or damping characteristic. Not only is it hard to read a fluctuating pointer, but at

20 Hz (c/s) or so, where the pointer is almost stationary, the lower of the two dampings (shorter time constants) will give rise to too low a reading. Above 40 Hz (c/s) the lower damping gives accurate results, and has the advantage that the pointer can easily follow changes in level.



Fig. 21. Oscilloscope photograph of the B & K True R.M.S. rectifier characteristics as used in the Electronic Voltmeter Type 2409/2416. The same quantities are traced as in Fig. 19.



The circuit is a bridge rectifier with a meter in the center branch. The bridge arms consist of diodes and resistors. A capacitor is connected across the meter. The circuit is designed to measure the true R.M.S. value of an AC signal. The meter is a moving coil type with a damping mechanism. The circuit is powered by a 240V AC source. The meter is connected to the bridge through a series resistor. The capacitor is connected across the meter to provide a time constant for the measurement. The circuit is designed to be accurate for frequencies up to 40 Hz. The meter is a 240V type. The circuit is a bridge rectifier with a meter in the center branch. The bridge arms consist of diodes and resistors. A capacitor is connected across the meter. The circuit is designed to measure the true R.M.S. value of an AC signal. The meter is a moving coil type with a damping mechanism. The circuit is powered by a 240V AC source. The meter is connected to the bridge through a series resistor. The capacitor is connected across the meter to provide a time constant for the measurement. The circuit is designed to be accurate for frequencies up to 40 Hz. The meter is a 240V type.

Specification

Frequency Response:	Linear to within 2% (± 0.2 dB) RMS from 2 Hz (c/s) to 200000 Hz (c/s).
Voltage Ranges:	Full deflection for 10 — 31.5 — 100 and 315 mV and for 1 — 3.15 — 10 — 31.5 — 100 — 315 and 1000 volts.
Input Impedance:	10 M Ω paralleled by 20 μ F.
Meter Indication:	The instrument can be switched to read Peak (half peak-to-peak), Average Absolute, or True RMS values.
Accuracy:	<i>Attenuator</i> , better than 2% at 1000 Hz (c/s). <i>Meter scale</i> , better than 1% of full scale deflection. <i>Peak rectifier circuit</i> , 2% of the read value. <i>Average rectifier circuit</i> , ± 1 % of the read value. <i>R.M.S. rectifier circuit</i> , ± 6 % for crest factors up to 5. Probable error for most common waveforms, ± 2 %. Calibrated on sine waves.
Meter Damping:	Two characteristics. Low damping, in accordance with the standards for "vu" measurements. High damping for measurement at low frequencies.
Stability:	Instrument stabilized to compensate for line voltage variations. For a 10% variation in line voltage the meter deflection will change less than 2%.
Sensitivity Adjustment:	Simple pre-set potentiometer, externally accessible. Built in reference voltage which alters less than 0.5% for a line voltage variation of 10%.
Scales:	Illuminated and graduated in volts from 0 to 10 V and from 0 to 31.5 V. Also in dB above 1 volt (0—20 dB) and in dbm, which is here defined as dB re. 0.775 V (0—22.2 dbm).

Gain: 0.01 to 1000 times. (—40 to +60 dB in 10 dB steps.)

Output Impedance: Approx. 50 ohms in series with 25 μ F.

Output Current: 8 mA max from amplifier.

Distortion: Less than 0.2 % with an output voltage of 10 Volts.

Hum and Noise: With open circuit input and maximum amplification the hum and noise level is equivalent to less than 100 μ volts at the input terminals, and it is equivalent to less than 20 μ volts with short circuited input terminals.

Tubes: 12AX7 (ECC83), 6U8 (ECC82), 6X4 (EZ90), and OA2.

Power Supply: 100 — 115 — 127 — 150 — 220 — 240 Volts,
Frequency 50—400 Hz (c/s).
Consumption 28 W approx.

Dimensions:

	2409	2416
Height	10" (26 cm)	7" (18 cm)
Width	7" (18 cm)	19" (48 cm)
Depth	5" (13 cm)	5½" (14 cm)

(Excluding dials and knobs).

Weight:

	2409	2416
Lbs.	10	16
Kg	4.5	7

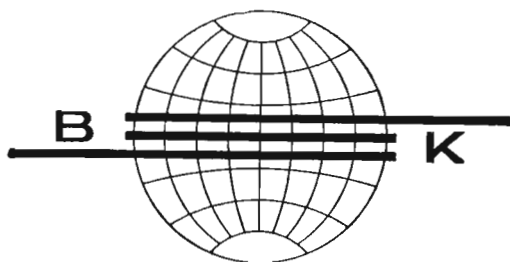

MARCH 1961
Valid from Serial no. 63.203

Parts-List

and

Trouble Shooting

Electronic Voltmeter

Type 2409/2416

Brüel & Kjær



DENMARK

PARTS - LIST 2409 / 2416

Component Type	Stock Reference	Circuit-diagram Reference	
Power cord, Enr.	AN 0005		
Power cord, USA	AN 0006		
Capacitors:			
Electrolytic	4 μ F/250 V	CE 2034	C 1
»	40 μ F/150 V	CE 2038	C 7, 8
»	24 μ F/ 25 V ~	CE 3520	C 5
»	2 \times 100 μ F/350 V	CE 2989	C 9, 10
»	500 μ F/3-4 V	CE 3498	C 13, 14
»	16 μ F/450 V	CE 6846	C 4
»	25 μ F/ 50 V	CE 8948	C 6
»	200 μ F/ 6 V	CE 8944	C 11, 12
»	12 μ F/ 50 V	CE 8947	C 2
»	16 μ F/ 70 V	CE 8949	C 3
Ceramic	5 pF	CK 0034	C 29
»	25 pF	CK 0039	C 30
Metallized paper	8 μ F/160 V	CP 0010	C 27
»	16 μ F/160 V	CP 0005	C 28
Polyester	1 μ F/125 V	CS 0025	C 26
»	220 nF/125 V	CS 0017	C 25
»	47 nF/400 V	CS 0109	C 23, 24
Polystyrene	180 pF/200 V	CT 0233	C 21
»	21.6 nF/200 V	CT 3129	C 22
Trimmer	0.7—3 pF/400 V	CV 0113	C 31, 32
»	3—30 pF	CV 7864	C 33
Miscellaneous:			
Rubber foot (only for 2409)	DF 7007		
Spring for tube	DL 0025		
Meter	IN 2409	I	
Coaxial jack	JJ 0014		
Coaxial plug	JP 0018		
Jack for grounding	JT 6204		
Socket for ECC 83, V 1, ECF 82, V 2	JV 9012		
Socket for OA 2, V 3	JV 7505		
Cabinet (only for 2409)	KQ 2409		
Front plate (only for 2416)	FA 2416		
Attenuator switch (only for 2409)	OR 2409	O 1	
Attenuator switch (only for 2416)	OR 2416	O 1	
Meter switch (only for 2409)	OS 2409	O 2	
Meter switch (only for 2416)	OS 2416	O 2	
Power voltage selector	OA 0012	O 3	
Potentiometer 500 Ω /2 W	PQ 1501	P 1	

2409/2416

PARTS-LIST 2409 / 2416

Component Type	Stock Reference	Circuit-diagram Reference
Trimmer potentiometer	1 k Ω PG 2100	P 2
» »	5 k Ω PG 2500	P 3, 5
» »	100 k Ω PG 4102	P 4
» »	1 M Ω PG 5102	P 6
Bakelite knob (only for 2409)	SN 0807	
Bakelite knob (only for 2416)	SN 0810	
Power transformer	TN 8926	
Printed circuit	XC 0001	
» »	XC 0010	
» »	XC 0011	
Germanium diode	QV 0085	Q 2-7
Germanium diode	QV 0078	Q 1
Zener diode	QV 1106	Q 8
Silicon diode	QV 0211	Q 9
Resistors:		
Wire-wound 3 W	7 k Ω RO 0803	R 2
» »	6 W 25 k Ω RO 0900	R 3
» »	$\frac{1}{2}$ W RK 800 Ω	R 12
» »	$\frac{1}{3}$ W RK 0.8 M Ω	R 25
Carbon film $\frac{1}{2}$ W	RK 100 Ω	R 1
» »	RK 125 Ω	R 10
» »	RK 160 Ω	R 11
» »	RK 800 Ω	R 13
» »	RK 1 k Ω	R 1, 14
» »	RK 6.3 k Ω	R 50
» »	RK 20 k Ω	R 17
» »	RK 50 k Ω	R 18-20
» »	RK 100 k Ω	R 21, 22
» »	RK 160 k Ω	R 23-24
» »	RK 2 M Ω	R 26
» »	RK 3.15 M Ω	R 27
» »	RK 5 M Ω	R 28
» »	RK 25 M Ω	R 29, 30
» »	1 W RK 100 k Ω	R 31
» »	$\pm 5\%$ $\frac{1}{2}$ W RK 7 k Ω	R 15
» »	» » RK 10 k Ω	R 16
» »	» » RK 20 k Ω \rightarrow ∞	R 49
Precision Resistors:		
Carbon film $\pm 0.5\%$ $\frac{1}{2}$ W	RK 462.2 Ω	R 47
» » »	RK 1 k Ω	R 46
» » »	RK 1.01 k Ω	R 43
» » »	RK 3.15 k Ω	R 45

2409/2416

PARTS-LIST 2409 / 2416

Component Type	Stock Reference	Circuit-diagram Reference
Carbon film $\pm 0.5\%$ $\frac{1}{2}$ W	RK 10 k Ω	R 44
» $\frac{5}{\text{}}$ »	RK 101 k Ω	R 42
» $\pm 1\%$ »	RK 2.54 k Ω	R 48
» » »	RK 8.9 k Ω	R 51
» » »	RK 17.6 k Ω	R 52
» » »	RK 19.7 k Ω	R 53
» » »	RK 23.7 k Ω	R 54
» » »	RK 34.3 k Ω	R 55
» » »	RK 49 k Ω	R 56
» $\pm 0.5\%$ 1 W 10 M Ω	RH 0700	R 41
Tubes:		
Twin triode	12 AX 7 (ECC 83)	V 1
Triode-Pentode	6 U 8 (ECF 82)	V 2
Stabilizer	(O A 2)	V 3
Fuse 1 A	(VF 0008)	V 7
Pilot lamp	(VS 1271)	V 6

2109/2416

TROUBLE SHOOTING 2409 / 2416

Symptom and Condition	Defect	Cure
Apparatus dead, no scale light.	Defective fuse V 7. Defective switch N. Defective switch O 3. Defective transformer T.	Replace.
Apparatus dead, scale light working, stabilizer tube is not burning.	Defective transformer T. Defective diode Q 9 Defective tube V 3. Defective resistor R 3. Defective capacitor C 4.	Replace.
Apparatus dead, scale light working, stabilizer tube burning normally.	Defective tube V 1. Defective tube V 2. Defective capacitor C 7, 8, 9, 10.	Replace. Whenever V 2 is replaced, P 4 should be adjusted till Va (pin 6 on V 2) is 95 volts.
Meter not working. Apparatus normal on "Output" but no deflection on the meter.	Defective meter I. Defective germanium diode Q 3, 4, 5, 6, 7. Defective resistor R 49, 55. Defective switch O 2.	Repair or replace.
Apparatus normal on "RMS" but "Peak" or "Average" not working or indicating incorrect.	Defective resistor R 15, 50, P 5 Defective capacitor C 1, 6, 14, 28. Defective switch O 2.	Repair or replace.
Apparatus normal on "Average" but "RMS" does not work or indicates incorrect.	Defective germanium diode Q 6, 7. Defective capacitor C 12, 26, 27. Defective resistor R 48, 51, 52, 53, 54, 56. Defective switch O 2.	Repair or replace.
Reduced sensitivity, bad frequency characteristic, sensitivity adjustment not working sufficiently.	Fault in amplifier. Defective tube V 1, 2. Defective resistor or capacitor.	Replace.
Increased sensitivity — bad frequency characteristic. Sensitivity adjustment not working.	Fault in negative feedback, Defective potentiometer P 1. Defective resistor R 22, 25, P 6 Defective capacitor C 31.	Replace.
Frequency characteristic bad at low frequencies when 10 mV range is used.	Defective condenser C 2, 3, 11, 13, 23, 24, 25, 28. Defective resistor R 12, 14, 26, 27, 28, 29, 30.	Replace.
Frequency characteristic bad at high frequencies when 10 mV range is used.	Incorrect value of C 31. Defective tube V 1, 2.	Adjust.
Steps on range switch incorrect: at low frequency: at high frequency:	Defective resistor R-41-47. Grid current in V 1. Defective condenser C 21, 22, 29, 32, 33.	Adjust or replace.

2409/2416

TROUBLE SHOOTING 2409 / 2416

Symptom and Condition	Defect	Cure
Hum and noise level too high on 10 mV range with open input circuit.	Defective tube V 1. Defective or incorrectly adjusted potentiometer P 2. No screening effect from instrument cover.	Replace. Adjust or replace. Make sure that electrical contact is obtained between the different parts of the instrument housing.
Apparatus measuring correctly, but reference voltage incorrect.	Defective zenerdiode Q 8. Defective resistor R 16, 31, 43. Defective or incorrectly adjusted potentiometer P 3.	Replace. Adjust or replace.
Meter pointer deflects to maximum when the range switch is rotated.	Defective capacitor C 2.	Replace.

2409/2416

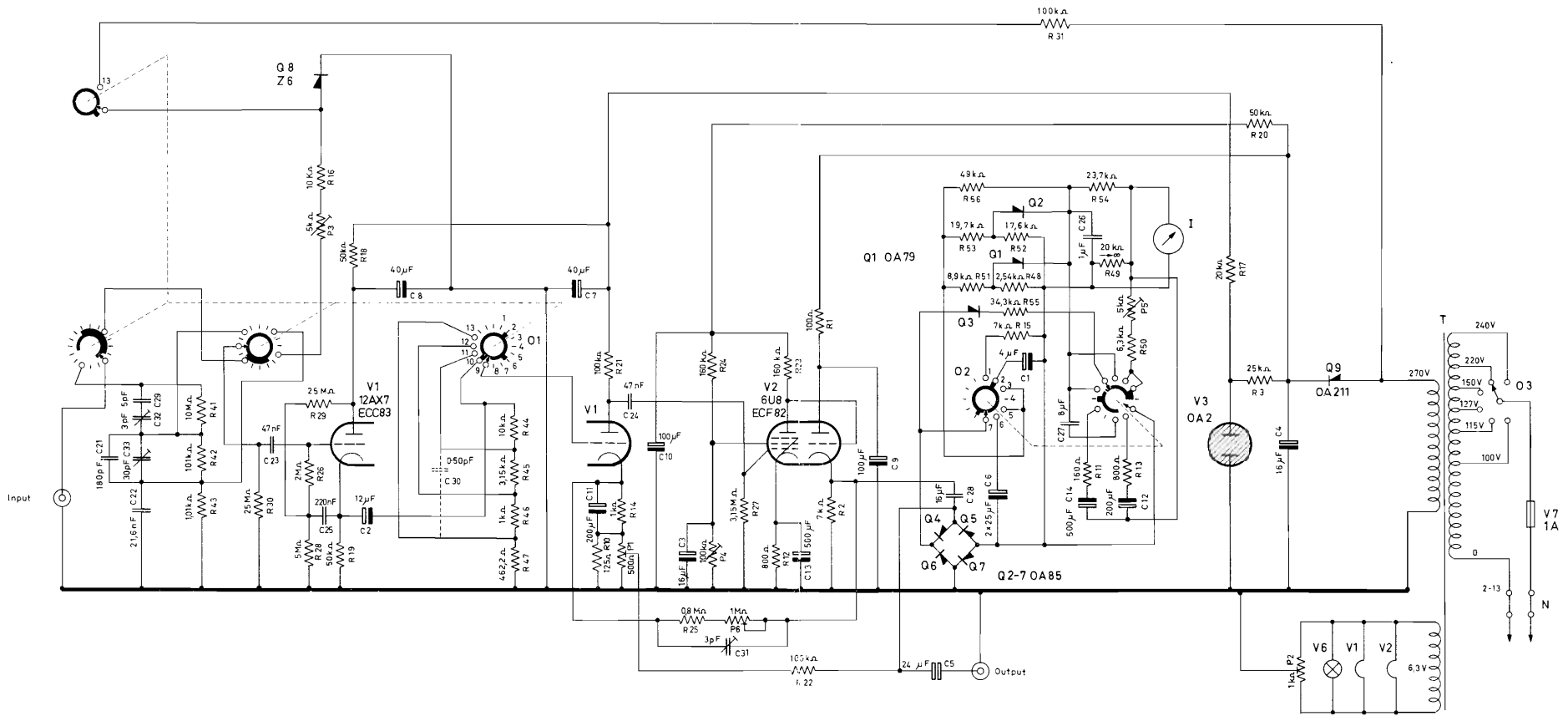

O1: Meter Range

- 1: Off
- 2: 0,01 V
- 3: 0,03 "
- 4: 0,1 "
- 5: 0,3 "
- 6: 1 V
- 7: 3 "
- 8: 10 "
- 9: 30 "
- 10: 100 "
- 11: 300 "
- 12: 1000 "
- 13: Ref.

O2: Meter Switch

- 1: Average Low Damping
- 2: Peak " "
- 3: RMS " "
- 4: Off " "
- 5: RMS High Damping
- 6: Peak " "
- 7: Average " "

All switches are shown in position 2.

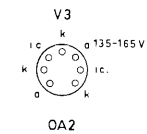
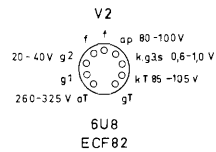
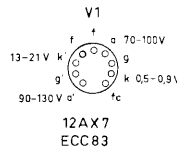

24-3-61	63203		

Brüel & Kjær
Copenhagen

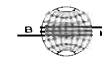

Electronic Voltmeter
Type 2409/2416