

# INSTRUCTION MANUAL

Type CMB11  
CAPACITANCE COMPARATOR



# RADIOMETER

ELECTRONIC MEASURING INSTRUMENTS  
FOR SCIENTIFIC AND INDUSTRIAL USE

GENERALAGENT

**BERGMAN & BEVING AB**

Huvudkontor: Karlav. 76 Stockholm 10 Tel. 08/679260  
Malmöfilialen: Carlsgatan 4 Malmö 1 Tel. 040/76760

## CONTENTS

|  | page |
|--|------|
| SPECIFICATIONS                             | 0-1  |
| SECTION 1 - GENERAL DESCRIPTION            | 1-1  |
| SECTION 2 - OPERATING PRINCIPLE            | 2-1  |
| SECTION 3 - OPERATING INSTRUCTIONS         |      |
| 3.1 Controls and terminals                 | 3-1  |
| 3.2 Preparing the instrument for operation | 3-2  |
| 3.3 Operating the instrument               | 3-2  |
| SECTION 4 - DETAILED DESCRIPTION           |      |
| 4.1 Introduction                           | 4-1  |
| 4.2 The 1 Megacycle generator              | 4-1  |
| 4.3 Measuring circuit                      | 4-1  |
| 4.4 Amplifier                              | 4-2  |
| 4.5 Phase sensitive detector               | 4-2  |
| 4.6 Power Supply                           | 4-4  |
| SECTION 5 - MAINTENANCE                    |      |
| 5.1 General                                | 5-1  |
| 5.2 Removing instrument from the cabinet   | 5-1  |
| 5.3 Tube replacement                       | 5-1  |
| 5.4 Potentials                             | 5-1  |
| 5.5 Adjustments                            | 5-2  |
| APPENDIX                                   |      |
| Complete circuit diagram                   |      |

## SPECIFICATIONS

## COMPARISON MEASUREMENTS

## RANGE

$\pm 1$ ,  $\pm 3$ ,  $\pm 10$ ,  $\pm 30$ ,  $\pm 100$ ,  $\pm 300$ , and  $\pm 1000$  pF, full scale.

First division at + and  $-0.02$  pF.

The value of the standard capacitor is limited to 1000 pF for the accuracy stated.

## ACCURACY

1% of reading + 1% of full scale or 0.05% of actual capacitance value, whichever is the greater.

## DIRECT MEASUREMENTS

## RANGE

1, 3, 10, 30, 100, 300, and 1000 pF, full scale.

First division at 0.02 pF.

## ACCURACY

1% of reading + 1% of full scale.

## SCALES

The meter has two linear scales,  $-3, 0, +3$ , and  $-10, 0, +10$  and has two movable reference pointers for limit settings.

## STABILITY

Less than 0.5% change in indication for a 5% change in line voltage.

## TEST SIGNAL

Frequency: 1 Mc  $\pm 0.1\%$

Voltage: 1.8 volts rms  $\pm 10\%$

## GUARD CIRCUIT

The guard circuit at each pair of terminals can be loaded with max. 500 pF without affecting the accuracy stated.

## TERMINALS

Binding posts for connection of the capacitors. A 5-pin Tuchel T3363 socket at the back of the cabinet is used for connecting the accessories.

## POWER SUPPLY

Voltages: 110, 115, 127, 200, 220, and 240 volts.

Line frequency: 50 to 60 cps.

Consumption: 65 watts.

## TUBES

2 E80CF (6B L8), 2 E188CC (6922 WA), 1 OB2.

All tubes are of the long-life type.

## MOUNTING

Steel cabinet finished in grey enamel with a sloping upper front panel for easy meter reading.

## OVER-ALL DIMENSIONS

| Height | Width | Depth |        |
|--------|-------|-------|--------|
| 430    | 285   | 230   | mm     |
| 17     | 18    | 9     | inches |

## WEIGHT

12 kilos net (26 lbs.)

## ACCESSORY SUPPLIED

1 type 12G19-1.5 power cord

## EXTRA ACCESSORIES

Component Adapter, type IM501

Component Jig, type KPH1

## SECTION 1 GENERAL DESCRIPTION

The 1 Mc Capacitance Comparator can measure small capacitors in agreement with the I.E.C. and MIL recommendations. It has been developed mainly for use in production and acceptance control, but is equally useful as a laboratory instrument.

Without any balancing it measures either capacitance directly from 0.02 pF to 1000 pF, or it makes comparative measurements with a standard capacitor, measuring differences from 0.02 pF to 1000 pF. Both sign and magnitude are indicated by the meter which has two auxiliary, movable pointers for tolerance settings for rapid "go-no-go" measurements.

The measurement is not affected by stray capacitance from a capacitor to its surrounding or by leakage and dielectric loss. The instrument incorporates a guard circuit which also permits the measurement of remote capacitors, for example in environmental test chambers.

To prevent wrong settings the range switch has a locking device which is operated with a screw driver, as are all the other controls.

The instrument has outputs that can be connected to limit sensing devices to operate sorting machines, control lamps, etc.

The component jig is used for rapid measurement or sorting of capacitors. It contains an electrically operated component clamping mechanism, operated by a foot switch.



## SECTION 2 OPERATING PRINCIPLE

The operating principle of the instrument is shown in fig. 1 below.

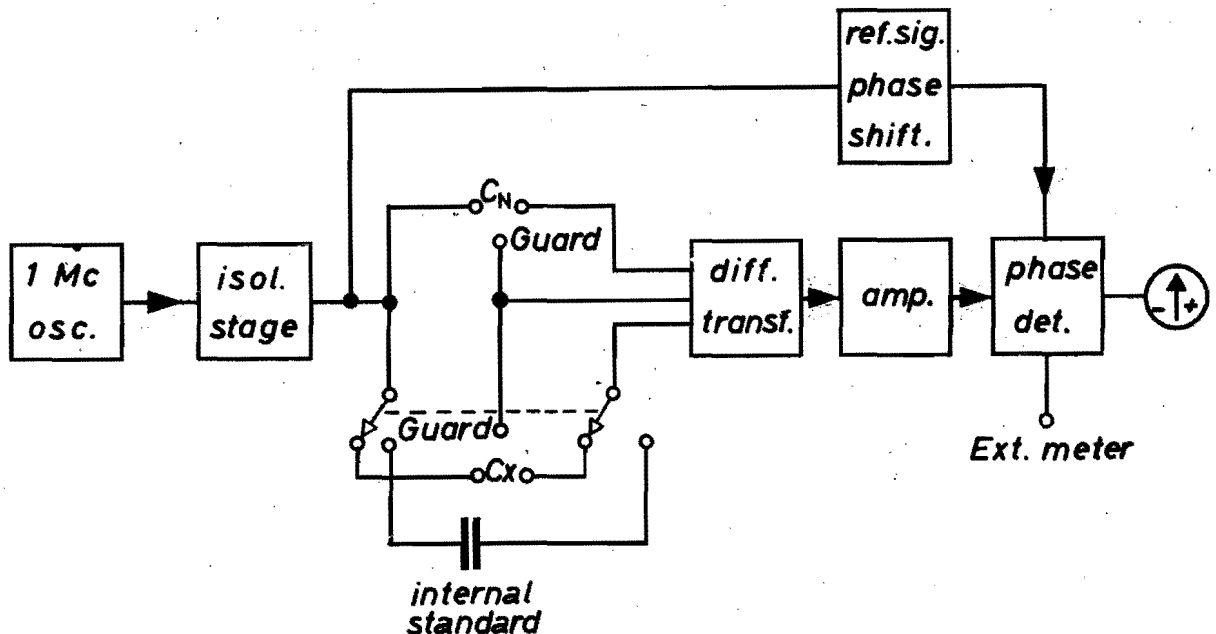

Fig. 1

### Simplified schematic diagram of type CMB11 Capacitance Comparator

A stable 1 Mc test voltage is obtained from a crystal controlled oscillator with an isolating stage. Between the test signal source and each of the two branches of a differential current transformer are inserted a pair of terminals. One takes a standard capacitor  $C_N$ , the other an unknown capacitor  $C_X$ . If the two capacitors inserted are of equal value, no current is coupled to the transformer secondary, while any difference in value produces an unbalance-current which is proportional to the difference between the two capacitors. The unbalance signal is passed through an attenuator to an amplifier with a strong negative feed-back, and finally to a phase sensitive detector which also receives a reference signal which is  $90^\circ$  out of phase with the test voltage. The detector output is coupled to a meter with zero at the center. The meter current is proportional to the difference between the two capacitances connected to the two pairs of terminals, and is independent of the difference

in the loss factors of the two capacitors. The losses produce a current in phase with the test voltage that is not detected by the phase sensitive detector. This however, holds true only if the loss components are relatively small so that the amplifier is not overloaded. The permissible difference between the loss factors of the two capacitors is a function of the capacitance and the attenuator (Range) setting. In fig. 2 the maximum difference in the loss factors,  $\Delta \text{tg} \delta$ , is plotted for the various ranges.

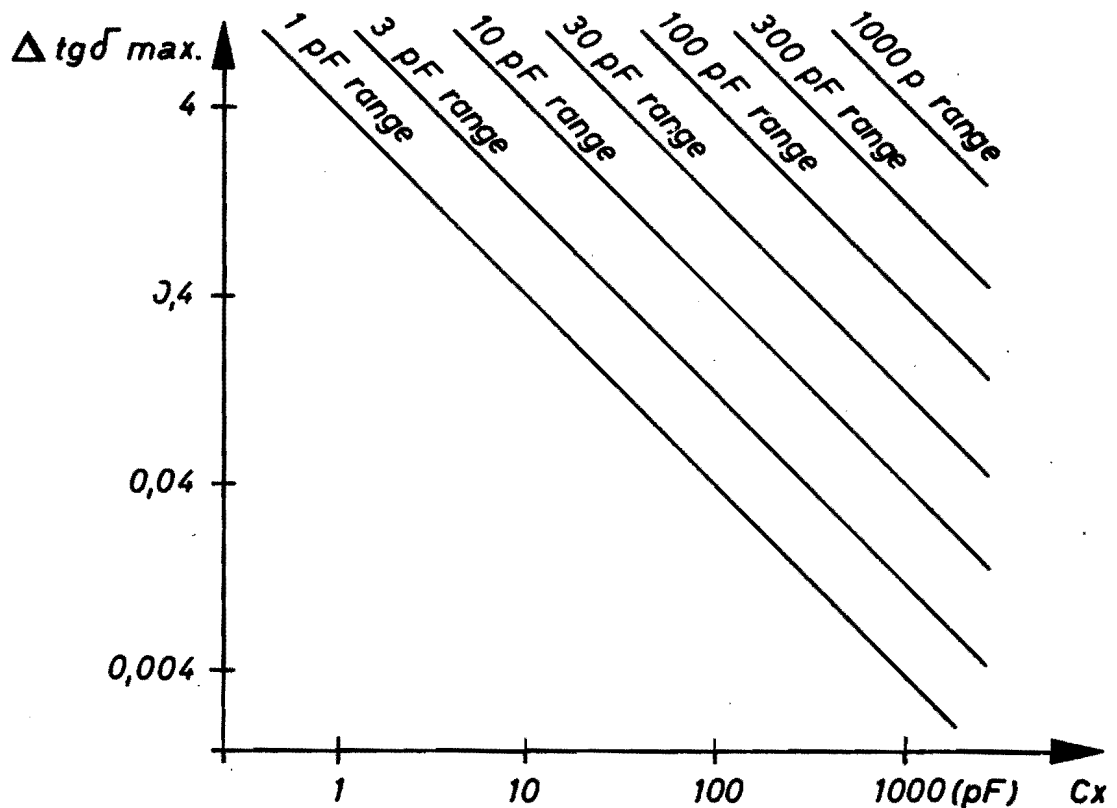

Fig. 2

Maximum allowable difference in loss factor to avoid misreading the capacitance difference

To measure the absolute value of a capacitor the terminals that receive a standard capacitor are left open, and the meter indicates the value directly.

In this case, the loss factor can be as high as 4 without affecting the measurement since by selecting the proper range the loss current is automatically attenuated in the same proportion as the capacitive current.

Calibration is simple. By pressing the CAL push button an internal standard capacitor of 100 pF is measured, and the amplifier gain can be adjusted to

the correct value. Because of the strong negative feedback the stability of the instrument is excellent, and readjusting the calibration control is seldom necessary. The CAL switch automatically disconnects the capacitors connected to the terminals from the measuring circuit, and it selects the 100 pF range regardless of the setting of the RANGE selector. This makes it easy to check the calibration at any time.

When measuring on 3-terminal capacitors, guard terminals are used (one at each pair of terminals) to eliminate influence from undesired capacities. Each guard terminal can be loaded with maximum 500 pF without affecting the accuracy stated in the specifications. The guard terminals are also used if it is necessary to use shielded cables to connect the capacitors to the instrument. This is more convenient for making measurements in connection with a climatic chamber when the capacitance comparator and a standard capacitor are located outside the chamber containing the sample.

The guard terminals are at ground potential so that all stray capacities to ground are connected to the guard circuit and prevented from affecting the measurement.



### SECTION 3 OPERATING INSTRUCTIONS

#### 3.1 CONTROLS AND TERMINALS

The following controls and terminals are located on the front panel of the instrument:

|                            |  |
|----------------------------|--|
| ON-OFF                     | Power switch   |
| CAL.                       | Push-button. Used when calibrating   |
| CALIBRATE                  | Potentiometer. Used to calibrate the instrument. Is adjusted with a screw-driver.  |
| MEASURE                    | Push-button. Used during measurements.   |
| RANGE                      | 7-position rotary switch. Used to select the desired range. It is locked by turning the locking device half-way round.               |
| $C_X$                      | Terminals. Used to connect the capacitor to be measured. The red terminal is the common generator terminal.                          |
| $C_N$                      | Terminals. Used to connect the standard capacitor during comparison measurements. The red terminal is the common generator terminal. |
| BALANCE                    | Trimmer. Used to set the zero of the instrument when the capacitors have been removed. Adjusted with a screw-driver.                 |
| GUARD                      | Terminals. Used for connecting to guard circuits.  |
| Tolerance-limit indicators | Auxiliary pointers which are set to indicate the desired limits. Actuated by knobs on the meter housing.                             |

The back has:

- Power cord receptacle
- Line voltage selector
- Fuse
- Tuchel-connector for extra accessories
- Meter circuit opening slide-switch to be used with accessories

### 3.2 PREPARING THE INSTRUMENT FOR OPERATION

The following instructions should be followed before taking the instrument into operation for the first time:

- (1) Make sure that the line voltage selector is set at the correct line voltage, and that the proper fuse is in the instrument. When the instrument leaves the factory, the voltage selector is set at 220 volts, and a 0.4 amp slow-blow fuse is incorporated. A 0.8 amp slow-blow fuse must be used, if the instrument is to operate on 110-127 volts.
- (2) Make sure that the line frequency is within the specified range. Instruments for other line frequencies can be supplied to order.
- (3) Check the mechanical zero-setting of the meter and reset, if necessary.
- (4) Connect the instrument to the power line with the cord supplied.
- (5) Set the RANGE switch to 1000 and the ON-OFF switch to ON. Allow the instrument to warm up for 1 hour, so that if there is any moisture it can be expelled.

Now the instrument is ready to be operated.

### 3.3 OPERATING THE INSTRUMENT

- (1) Connect the instrument to the power line and turn the power switch to ON.
- (2) Allow the instrument to warm up for 10 minutes.
- (3) Press the button CAL.
- (4) Set CALIBRATION control so that the meter gives full-scale deflection.
- (5) Press the button MEASURE.
- (6) If component adapters, extension cable, or guard systems are to be used, connect them, but not the capacitors to be measured, to the instrument.
- (7) Set the RANGE switch to 1 pF.
- (8) Set the trimmer BALANCE with a long-handled screw driver so that the meter reads zero.
- (9) Set the RANGE switch to the desired full-scale value.

The instrument is now ready for use.

#### 3.31 Direct capacitance measurements

Connect the capacitor to be measured to the  $C_x$  terminals. The instrument indicates the capacitance in pF with an accuracy up to 1% of full scale value +1% of the reading.

## 3.32 Comparison measurements

When comparing the capacitance of two capacitors, one serves as a reference, and the other is the unknown.

Connect the reference capacitor to the  $C_N$  terminals and the unknown capacitor to the  $C_X$  terminals. Now the instrument indicates the difference,  $C_X - C_N$  in pF and the sign of the difference.

When using a variable standard capacitor and the instrument as null detector, an accuracy better than 0.01 pF or 0.05%, whichever is the greater, can be had.

In order to have the previously mentioned accuracy make sure that the inductance of the external connections is small and equal in the  $C_X$  and the  $C_N$  arms, especially when comparing large capacitors (above 100 pF).

Differences in inductance are indicated by two unequal readings of  $|C_1^X - C_2^N|$  and  $|C_2^X - C_1^N|$ , which are had when interchanging the two almost-equal capacitors,  $C_1$  and  $C_2$ , in the  $C_X$  and  $C_N$  terminals.

The inductances in the instrument are balanced to within 0.01  $\mu$ H and insure that the full accuracy is maintained when connecting the capacitor directly to the terminals. When using extension cables, component adapters etc., the inductance should be either equalized by using short pieces of cable, or a correction must be applied to the readings.

The correction is given by

$$\Delta C = \frac{(C_1^X - C_2^N) + (C_2^X - C_1^N)}{2}$$

subtracted from the reading  $C_1^X - C_2^N$ .

The correction  $\Delta C$  can be applied to all subsequent measurements of capacitors  $C_1$  as long as their capacitances are of the same order of magnitude as that of the capacitor used to find the correction factor. Generally the true capacitance difference will be

$$C_1 - C_2 = \frac{(C_1^X - C_2^N) - (C_2^X - C_1^N)}{2}$$

Using double shielded cable with the inner shield connected to the

guard terminal ensures relatively small inductance and freedom from cable capacitance influences.

Note: To maintain full accuracy of the instrument, the calibration should be checked after the first half hour of operation and subsequently every hour.

To do so, press the push-button CAL. and readjust CAL-IBRATION so that the meter needle deflects to the calibration mark. This check should be made with the capacitors to be measured connected to the terminals, so that the voltage generator is properly loaded.

## SECTION 4 DETAILED DESCRIPTION

### 4.1 INTRODUCTION

The type CMB11 Capacitance Comparator essentially consists of 5 sub-units:

- (1) the 1 Mc generator
- (2) the measuring circuit
- (3) the linear amplifier
- (4) the phase sensitive detector
- (5) the power supply

The complete circuit diagram of the instrument is appended to this manual.

### 4.2 THE 1-MEGACYCLE GENERATOR

As already stated, the generated voltage is practically constant in both frequency and amplitude.

The generator is made up of a crystal controlled 1-Mc oscillator (V1a), a buffer stage (V1b), an output stage (V2), and a matching network (T1, R25, and C12).

The open-circuit amplitude stability is better than  $\pm 0.2\%$  for  $\pm 5\%$  line voltage variations. This stability is had by operating the oscillator from a regulated supply voltage and by using almost unity gain cathode followers for the subsequent stages. Amplitude stability with varying capacitive load is had by the matching network. The capacitive loads, which are made up of  $C_X$ ,  $C_N$ , and capacitances connected to the guard terminals are made part of a parallel resonant circuit. In this way amplitude variations because of the finite output impedance of the output stage, are compensated for by resonance effects, and a stability is had which is better than  $\pm 0.2\%$  for capacitive load variations of  $\pm 1000$  pF, within specified loads.

### 4.3 MEASURING CIRCUIT

The measuring circuit is made up of the differential current transformer T2, the universal shunt, the RANGE switch S3, the MEASURE and CAL. switches S1 and S2, the terminals, and BALANCE device C15 and C16.

The current transformer T2 has a split balanced primary winding. The center tap of this winding is connected to the generator. Two currents flow in opposite directions through the two halves of the balanced primary. These currents are proportional to the capacitances which are connected to the ends. The current in the secondary winding is proportional to the difference of the two primary currents. The voltage set up in the universal shunt (R26-R36) by the secondary current is amplified and measured. The shunt is provided with taps to obtain the desired ranges.

With CAL. pressed in, C13 and C14 (whose combined capacitance is set to  $100 \pm 0.5$  pF at the factory) are connected to one end of the primary winding and produce a current with which the instrument is calibrated. During the calibration the capacitors connected across the terminals are automatically disconnected from the measuring circuit, and the RANGE switch is made inoperative.

When pressing the MEASURE switch, the CAL. switch is released, and the terminals  $C_X$  and  $C_N$  are connected to the windings of T2. Capacitors C15 and C16 are used to balance the terminal capacitance (as well as that of internal and external connections). C15 is accessible through a hole in the front panel and is marked BALANCE.

Inductance in the measuring circuit has to be kept to a minimum to prevent errors in measurement because of the series resonance. By careful wiring and transformer design the total series inductance in the instrument is kept below  $0.25 \mu\text{H}$  so that the errors introduced remain within the specifications.

#### 4.4 AMPLIFIER

The amplifier consists of two similar sections, V4 and V5.

Each section has a high gain tuned amplifier stage coupled to a broad-band amplifier stage with heavy negative feedback applied over both of them. The amplifier has a zero phase shift at the operating frequency, high input impedance, low output impedance and an amplification of 60 db which is approximately constant to within  $\pm 0.01$  db.

#### 4.5 PHASE SENSITIVE DETECTOR

The phase sensitive detector is of the linear, single ended type which utilizes video detector germanium diodes (CR2, CR3).



The reference voltage for the detector is taken from the generator output through a  $90^\circ$  phase shifting network and isolation amplifier (V3). The reference voltage is applied to the single ended winding of the modulation transformer T3 while the signal voltage which comes from the amplifier output is applied to the center of the split transformer winding. The voltages applied to the two diodes are  $\bar{V}_{\text{ref}} + \bar{V}_{\text{sign}}$  and  $\bar{V}_{\text{ref}} - \bar{V}_{\text{sign}}$ .  $\bar{V}_{\text{ref}}$  is large compared to  $\bar{V}_{\text{sign}}$ , so the two diodes conduct simultaneously during the positive half cycles of  $\bar{V}_{\text{ref}}$ . The rectified voltages measured on the diodes, will be  $K(\bar{V}_{\text{ref}} + \bar{I}_{\text{ref}} \cdot \bar{V}_{\text{sign}})$  and  $-K(\bar{V}_{\text{ref}} - \bar{I}_{\text{ref}} \cdot \bar{V}_{\text{sign}}) = K(\bar{I}_{\text{ref}} \cdot \bar{V}_{\text{sign}} - \bar{V}_{\text{ref}})$ .  $K$  is the rectification factor,  $\bar{I}_{\text{ref}} \cdot \bar{V}_{\text{sign}}$  the component of the signal voltage in phase with the reference. By the resistive adder, R54, R55, and R56, the sum of the rectified voltages,  $K \cdot \bar{I}_{\text{ref}} \cdot \bar{V}_{\text{sign}}$  is derived and indicated by the meter. The signal voltage component which is  $90^\circ$  out of phase with the reference voltage is not detected since averaged over the positive half cycle of the reference voltage, in which the diodes conduct, it is always zero. The component detected is proportional to the reactive current and accordingly to the capacitance  $C$ , while the component resulting from the losses is rejected. With  $C_X > C_N$  the meter deflects to  $\oplus$ . With  $C_X < C_N$  the meter deflects to  $\ominus$ . The meter deflection is controlled by the CALIBRATION control, R58.

The detector and meter terminals are brought out to the 5-pin Tuchel connector on the back of the instrument so that an external meter or a limit sensing device etc. may be connected. In normal use pin 1 and 2 are short circuited by the slide-switch S4 so that the internal meter is connected. When the instrument is used as a tolerance meter, it may be desirable to prevent the over-the-limit meter deflections when handling the components. In this case a switch may be inserted between pin 1 and 2 to open the meter circuit automatically while handling the components (as it is done in the type KPH1 Component Jig).

In case an external meter is used it should have a sensitivity of 0.25-0-0.25 mA and an internal resistance of approximately 500 ohms. It should be connected to pins 1 and 3 of the Tuchel connector thus replacing R59 in the meter circuit, when S4 is opened.

#### 4.6 POWER SUPPLY

With a voltage selector the primary of the line transformer, T4, can be set to any of the line voltages 110, 115, 127, 200, 220, and 240 volts. The voltage from the secondary of the line transformer is rectified in a bridge rectifier (CR1). All sub-units, except the oscillator, are supplied via R-C filters. The oscillator supply voltage is stabilized by the voltage regulator V6.

In addition the line transformer has 2 windings for filament supply of the oscillator and amplifier sections.

## SECTION 5 MAINTENANCE

### 5.1 GENERAL

The type CMB11 Capacitance Comparator was designed with special reference to industrial use so that it gives a long and reliable performance without maintenance. Should repairs become necessary, they should be made by skilled personnel who have the necessary equipment to ensure the proper repair and adjustment.

### 5.2 REMOVING THE INSTRUMENT FROM THE CABINET

After removing the eight binding-head screws at the edges of the front panel the instrument can be taken out of the cabinet.

### 5.3 TUBE REPLACEMENT

The tubes used in the instrument are long-life ruggedized types which very seldom require replacement. All tubes are accessible when the instrument has been removed from the cabinet. The tubes need not be selected.

### 5.4 POTENTIALS

The list of potentials below can be used when servicing the instrument. All potentials stated are referred to chassis and have been measured with a vacuum-tube voltmeter. Deviations up to 20% may be tolerated.

|                     |              |        |
|---------------------|--------------|--------|
| Tube No. 1 - E188CC | pin No. 1    | +108 V |
|                     | 2            | + 35 V |
|                     | 3            | + 37 V |
| Tube No. 2 - E188CC | pin No. 1, 6 | +120 V |
|                     | 2, 7         | + 37 V |
|                     | 3, 8         | + 39 V |
| Tube No. 3 - E188CC | pin No. 1    | +150 V |
|                     | 2            | + 22 V |
|                     | 3            | + 25 V |
|                     | 6            | +128 V |
|                     | 7            | + 19 V |
|                     | 8            | + 22 V |

|                    |                    |        |
|--------------------|--------------------|--------|
| Tube No. 4 - E80CF | pin No. 1          | +170 V |
|                    | 3                  | +175 V |
|                    | 6                  | +170 V |
|                    | 8                  | +5.9 V |
| Tube No. 5         | same as tube No. 4 |        |
| Tube No. 6         | pin No. 1.5        | +108 V |
| CR1 Rectifier      | +terminal          | +290 V |

## 5.5 ADJUSTMENTS

Do not change the adjustments made at the factory, unless repairs make this necessary. In that case remove the instrument from the cabinet and let it warm up for one hour. Next follow the procedure below:

### 5.51 Generator amplitude adjustment

Press CAL, set CALIBRATE to center position, and adjust R62 (power supply chassis, top) to obtain full scale reading on meter.

### 5.52 Detector null

Press MEASURE and balance on 1 pF range.  
Set RANGE to 1000 pF.  
Adjust R56 (detector print board, back) to obtain zero reading.

### 5.53 Amplifier tuning

Connect a vtvm with a high impedance detector probe to the amplifier output (upper corner of amplifier print board, right-hand side). Set RANGE to 30 pF and push CAL.  
Adjust L2, L3 and C19 (amplifier print board) to give maximum amplitude on vtvm. Disconnect the vtvm. Adjust R17 for maximum deflection of the internal meter.  
Push MEASURE and set RANGE to 1 pF.  
Set the observed amplitude to its previous value with the trimmer BALANCE:  
Adjust C18 (accessible through a hole in the cover over the CAL-MEASURE switch) to have maximum deflection.

### 5.54 After replacing the instrument in its cabinet readjust the detector null according to 5.52. R62 can be reached with a screwdriver through the hole in the back of the cabinet.

Performance tests are made by measuring standard capacitors, such as GR type 711.

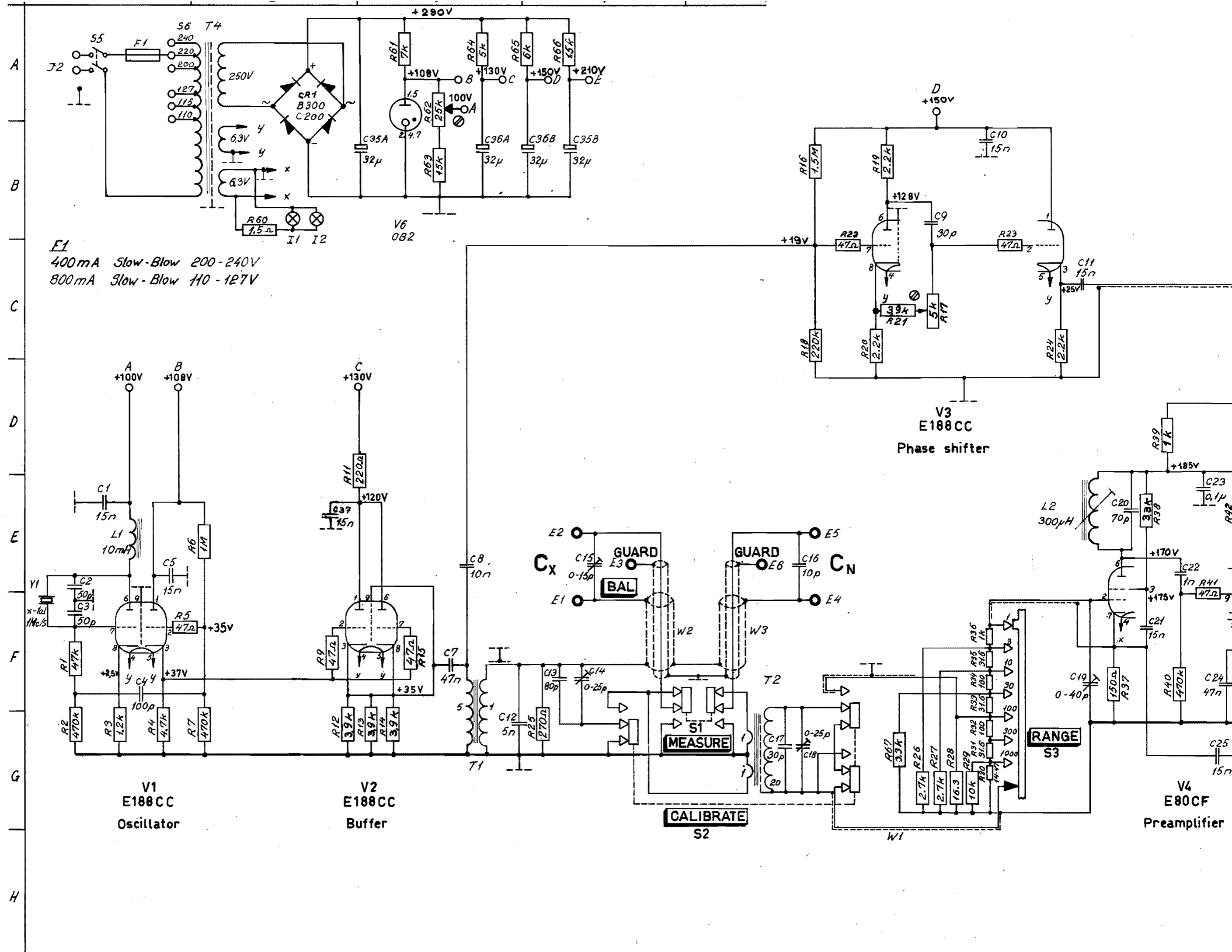

**F1**  
 400mA Slow-Blow 200-240V  
 800mA Slow-Blow 110-127V

**V3**  
 E188CC  
 Phase shifter

**V1**  
 E188CC  
 Oscillator

**V2**  
 E188CC  
 Buffer

**S1**  
 MEASURE

**S2**  
 CALIBRATE

**S3**  
 RANGE

**V4**  
 E80CF  
 Preamplifier

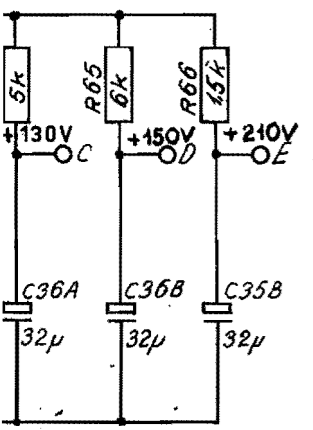

**RADIOMETER**  
COPENHAGEN

This drawing must not be passed on to any person not authorized by us to receive it, nor be copied or otherwise made use of by such person without our authority

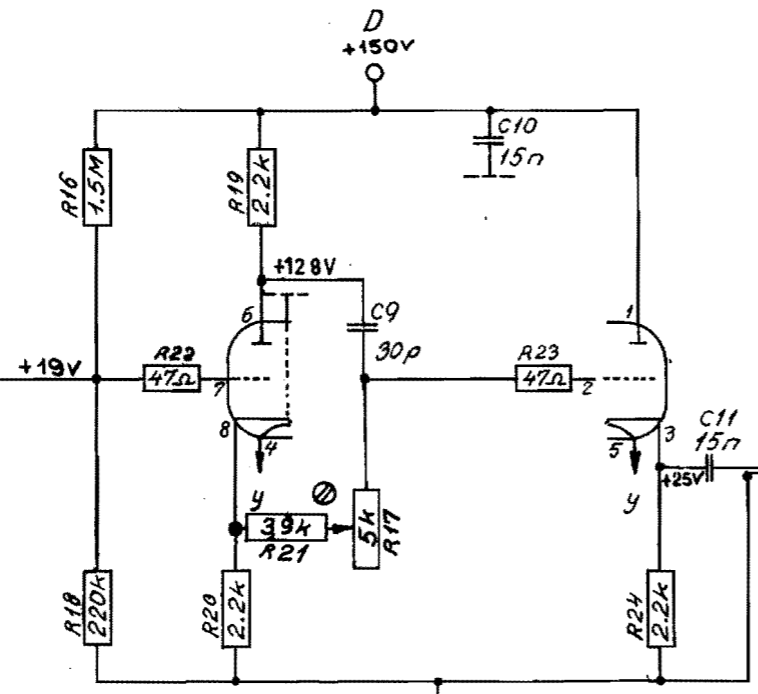

**V3**  
E188CC  
Phase shifter

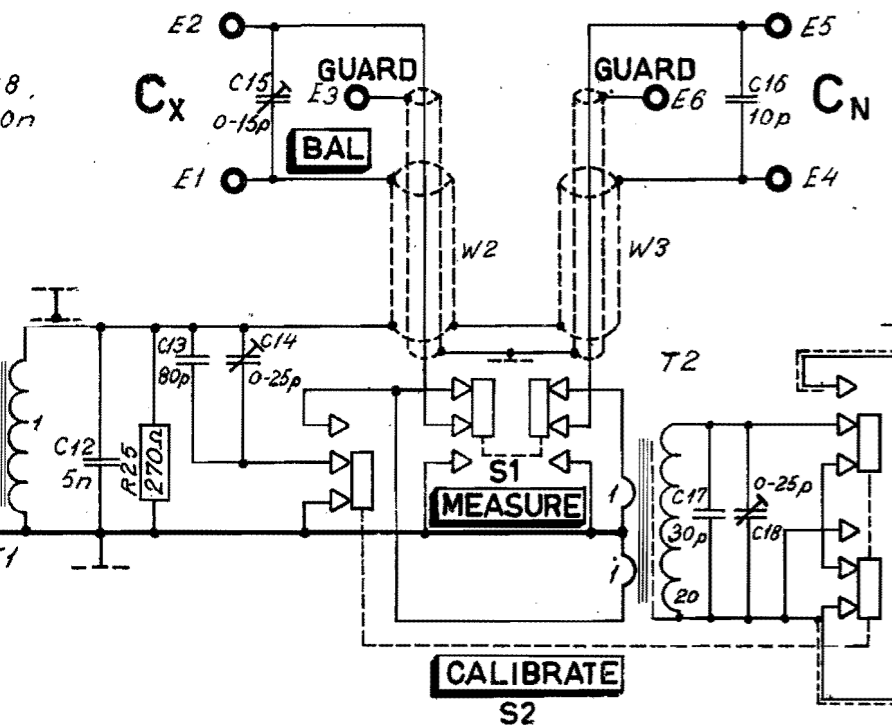

**S2**  
CALIBRATE

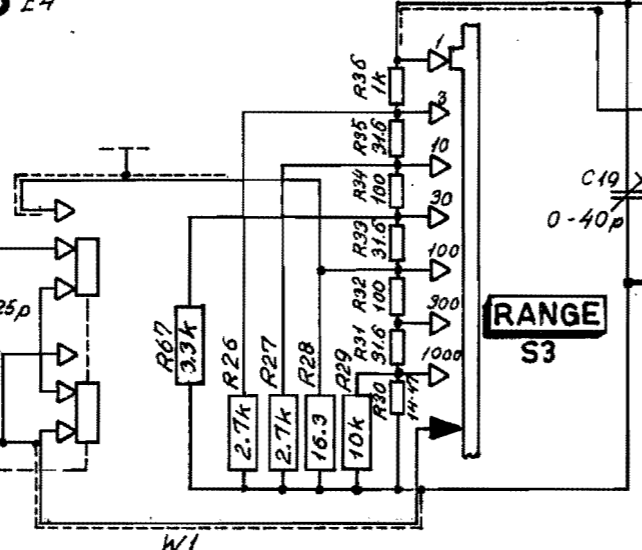

**S3**  
RANGE

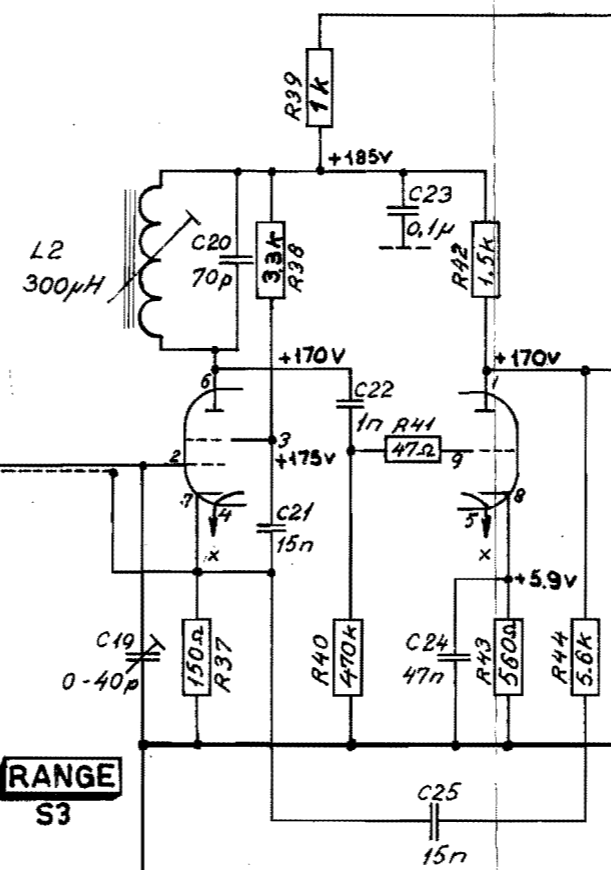

**V4**  
E80CF  
Preamplifier

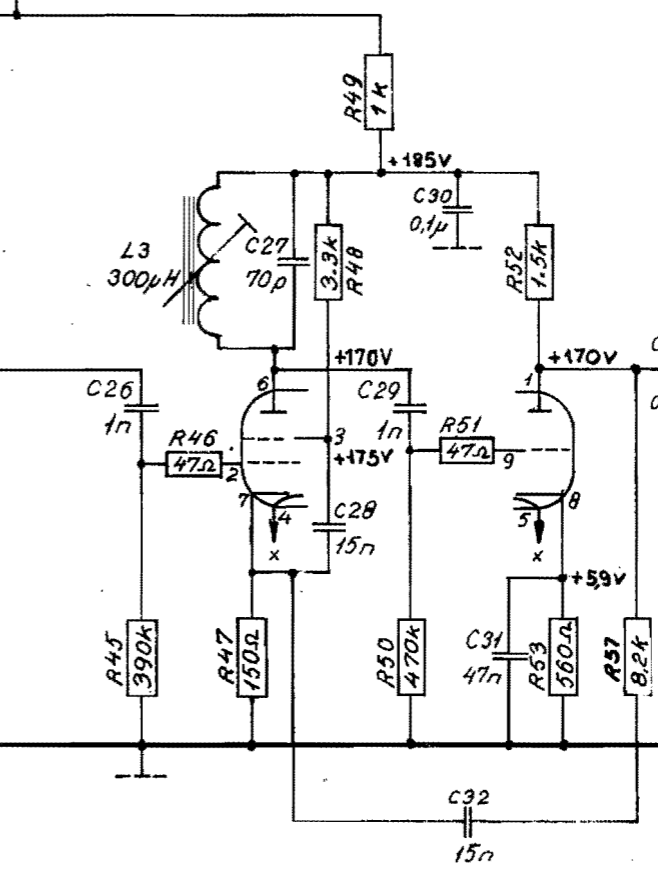

**V5**  
E80CF  
Amplifier

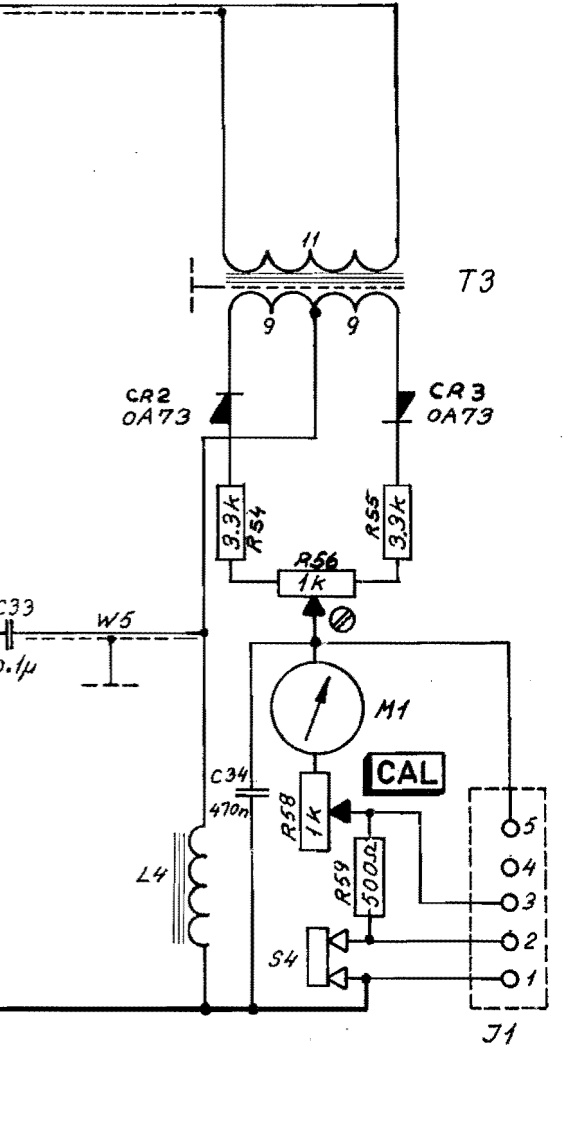

**Detector**

|         |              |      |        |       |       |
|---------|--------------|------|--------|-------|-------|
| 6       | 16/5-62      | EP   |        |       |       |
| 5       | 18-4-62      | EP   |        |       |       |
| 4       | 27/3-62      | HJ   | EP     |       |       |
| 3       | 28/2-62      | EP   |        |       |       |
| 2       | 20/9-61      | EP   |        |       |       |
| 1       | 20/9-61      | EP   |        |       |       |
| Rt. Nr. | Fra Fab. Nr. | Date | Rt. af | Konf. | Norm. |

**RADIOMETER** **COPENHAGEN**

**72 EMDRUPVEJ NV**

Capacitance Comparator  
**TYPE CMB11a**  
From no. 45572 to no.

|          |       |        |        |
|----------|-------|--------|--------|
| Målestok | Tegn. | L.T.J. | 2/6-61 |
| ~        | Konf. | J.G.   | 7/6-61 |
| Norm.    |       |        |        |

Erstatter  
**1348-A2**  
Erstattes af





**RADIOMETER - 72, EMDRUPVEJ - COPENHAGEN NV - DENMARK**