

FA 8

# INSTRUCTION MANUAL

Wave Analyzer  
type FRA3



# RADIOMETER

ELECTRONIC MEASURING INSTRUMENTS  
FOR SCIENTIFIC AND INDUSTRIAL USE

## TABLE OF CONTENTS

	page
SECTION A - INTRODUCTION	A1
SECTION B - SPECIFICATIONS	B1
SECTION C - ACCESSORIES	C1
1. Sweep Drive Gear Box, type SDG1	C1
2. Balancing Transformer, type BAT11	C5
SECTION D - OPERATING PRINCIPLE	D1
1. Operating Principle of the Analyzer	D1
2. Operating Principle of the Tone Generator	D2
3. Controls, Terminals and Meter of the Analyzer	D3
4. Line Voltage Receptacle, Fuse, and Voltage Selector	D7
SECTION E - OPERATING INSTRUCTIONS	E1
1. General	E1
2. Step-By-Step Operation	E1
SECTION F - CIRCUIT DESCRIPTION	F1
1. Input Attenuator	F1
2. Input Amplifier	F1
3. 60 kc Input Low-Pass Filter	F2
4. First Mixer	F2
5. Flip-Flop	F3
6. F-Oscillator	F3
7. 120 kc IF Band-Pass Filter	F4
8. Emitter-Follower	F4
9. Second Mixer	F5
10. Second Oscillator (118 kc $\pm$ 100 cps)	F5
11. Shaper	F5
12. 2 kc Band-Pass Filter	F6
13. 2 kc Buffer Amplifier	F6
14. 2 kc Amplifier No.1	F7
15. Meter Range Attenuator	F7

16. 2 kc Amplifier No.2	F8
17. Meter Amplifier	F8
18. Meter Rectifier	F8
19. A-Oscillator	F9
20. Regulating Stage	F9
21. AGC Amplifier	F9
22. 120 kc BFO Band-Pass Filter	F10
23. BFO Buffer for Mixer	F10
24. BFO Mixer	F10
25. 60 kc BFO Low-Pass Filter	F11
26. Amplitude Potentiometer	F11
27. BFO Voltage Amplifier	F11
28. BFO Output Emitter-Follower	F11
29. 1 kc Square-Wave Calibrator	F12
30. Power Supply	F12

# Wave Analyzer type FRA3

## Section A. Introduction

The Wave Analyzer, type FRA3, is a solid-state, line-operated, heterodyne wave analyzer with six constant bandwidths.

It is chiefly designed for harmonic and noise analyses, selective measurement of frequency characteristics and intermodulation measurements. Due to the extremely low distortion, hum and noise level combined with great sensitivity ( $30 \mu\text{V}$  f.s. deflection), frequency analyses are carried out with very high accuracy within the frequency range from 10 cps to 60 kc.

The frequency can be determined with an accuracy of  $0.3\% + 3$  cps on a 6.9 meters long linear frequency scale bearing divisions for every 10 cps. By means of a multiplier switch, the range can be converted into a 10 cps to 6 kc range with a division for every cps and an accuracy of  $1\% + 3$  cps.

The tuning of the Wave Analyzer can be accomplished automatically with an ex-

ternal motor - e.g. an external recorder - via the Sweep Drive Gear Box, type SDG1, or manually - either slowly with a fine frequency tuning knob, or rapidly with the main frequency tuning-knob, which due to the elaborate flywheel construction of the frequency dial, permits the total frequency range to be scanned by a single twist of the tuning knob.

To increase the measuring speed and accuracy of harmonic analyses, the Wave Analyzer is equipped with a pushbutton that switches the selective frequency response into a flat response, and at the same time decreases the sensitivity to provide for an accurate check of the overall level of the input signal.

The very well-defined data of the band pass filters gives an effective noise bandwidth of  $1.04 \times$  the 3 dB bandwidths to be obtained for all six bandwidths, and renders the Wave Analyzer especially suited for noise analyses. Furthermore,

the indicating meter responds to the rms value of white noise and has in addition to the regular integrating time an increased, switchable integrating time for narrow-band analyses:

In order readily and accurately to accomplish selective measurements of the frequency response, the Wave Analyzer features a built-in beat-frequency oscillator. The frequency of the low-distortion output signal from the BFO is synchronized to the frequency to which the analyzer section is tuned, or it has a constant difference continuously adjustable between  $-2$  kc and  $+2$  kc. The BFO is provided with an AGC circuit enabling variations of the signal level at any preselected point in the system under test to be reduced from 40 dB to 1 dB.

Throughout the entire frequency range, continuous intermodulation measurements can easily be performed by means of the

detuning facility of the BFO in combination with a built-in super-position network having input terminals that provide for connection to an external oscillator.

Besides being indicated on the meter, the output signal of the Wave Analyzer is available as a 2 kc signal on a recorder output socket. With a dynamic range of more than 80 dB, the analyzer is excellently suited for recordings of noise, frequency spectra and intermodulation phenomena.

The versatility of the Wave Analyzer with respect to special applications is greatly increased by a series of terminals situated on the rear of the instrument. Among other possibilities, the Wave Analyzer can be driven from an external oscillator with a frequency range of 240-360 kc and thus act as a slave analyzer, provided that the external oscillator is that of a second Wave Analyzer, type FRA3.

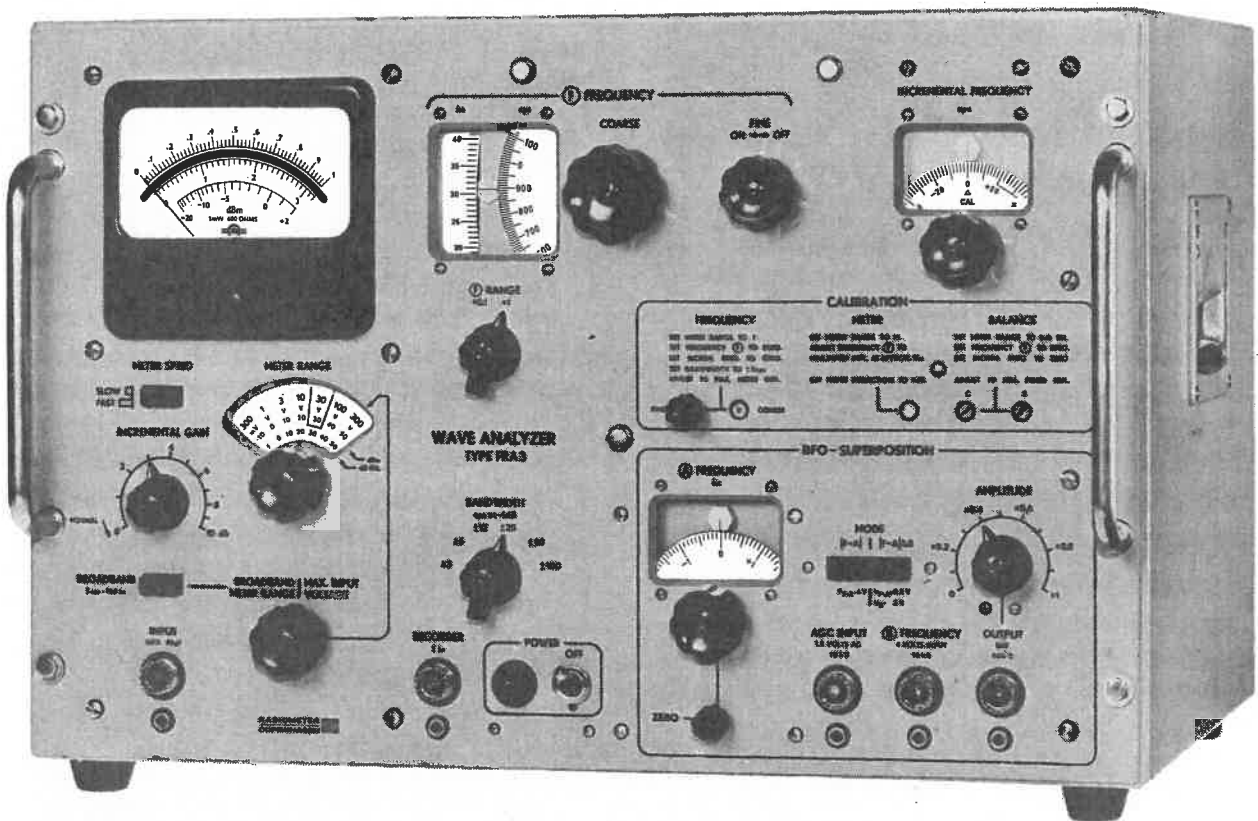

Fig. 1. The Wave Analyzer, type FRA3.

## Section B. Specifications

### FREQUENCY

- Ranges:** 10 cps to 60 kc (63) and 10 cps to 6 kc.
- Calibration:** Drum dial with engravings for each kilocycle (0.1 kc).  
Flywheel dial with engravings for each 10 cps (1 cps).  
Strictly linear scales. Length: 6.9 meters.  
No perceptible backlash.  
60 kc travel by a single twist of the flywheel dial.
- Accuracy of Calibration:** On 60 kc range: 0.3% + 3 cps. Typically 0.1% + 3 cps.  
On 6 kc range: 1% + 3 cps. Typically 0.5% + 3 cps.
- Drift:** Approx. 3 cps in second hour at low frequencies,  
10 cps at 60 kc. Less later on.
- Incremental Frequency:** Incremental frequency dial calibrated from 0 to  $\pm 100$  cps with a division for each 2 cps. Calibration independent of setting of main dial.
- Selectivity:** 6 bandwidths selected by switch.  
All selectivity curves are flat-topped and steadily sloping  
-1 dB at:  $\pm 3 \pm 6 \pm 12 \pm 25 \pm 50$  and  $\pm 100$  cps detuning.  
-50 dB at:  $+25 + 50 + 100 + 200 + 400$  and  $+800$  cps detuning.  
-50 dB at:  $-25 - 50 - 90 - 175 - 300$  and  $-500$  cps detuning.  
-100 dB at:  $+100 + 200 + 400 + 800 + 1200$  and  $+1600$  cps detuning.  
-100 dB at:  $-100 - 200 - 300 - 500 - 800$  and  $-1000$  cps detuning.  
BROADBAND pushbutton converts Analyzer into an untuned voltmeter with 20 cps - 60 kc range. Response within 0.3 dB. (10 cps - 300 kc range; response within 1 dB.)  
Effective bandwidth for noise 1.04 times 3 dB bandwidth.  
3 dB bandwidth typically 9-18-36-72-144-288 cps.

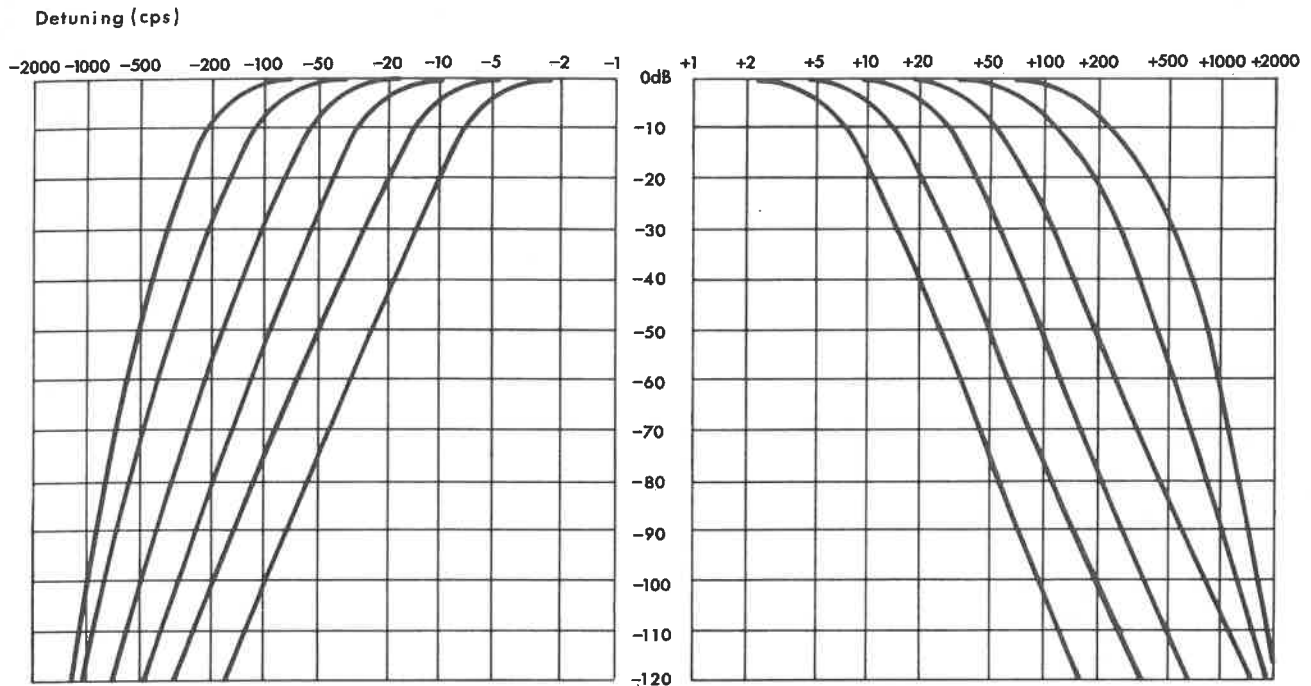

Fig.2. Typical response curves of the Wave Analyzer, type FRA3.

BROADBAND pushbutton converts the analyzer into an un-tuned voltmeter with 20 cps - 60 kc range. Response within 0.3 dB. (10 cps - 300 kc range. Response: 1 dB).

## VOLTAGE

### Total range:

30  $\mu$ V to 300 V full scale in a 1-3-10 sequence.

0 to +10 dB continuously by INCREMENTAL GAIN control. Scale with subdivisions calibrated at 0 and +10 dB.

Voltage ranges also valid in noise measurements, even at full deflection, because an overdrive of 10 dB with sinusoidal input is tolerable.

### Sensitivity:

Lowest detectable voltage is below 2  $\mu$ V.

### Meter:

Meter senses rms value of noise spectra and up to five superimposed sinusoidal voltages of equal magnitude, even at full deflection. 2 meter speeds by pushbutton that changes integrating time of full-wave rectifier. Taut-band suspension.

Meter Scales:	Linear 0 - 1 and 0 - 3. Logarithmic: -20 to +2 dB ref. to 1 mW/600 $\Omega$ . Mirror-backed scales.
Accuracy:	5% of full-scale value (20 (10) cps - 60 kc). Calibration from built-in 1 kc oscillator.
Drift:	Approx. 1%, completed in first hour.
Harmonic Distortion:	Less than -85 dB (typically -95 dB). At low frequencies a rise of some dB can occur.
Spurious voltages:	Will not disturb -85 dB signals.
Hum:	Less than -100 dB with INCREMENTAL GAIN at 0 dB. Typically 10 dB lower. Less than -90 dB with INCREMENTAL GAIN at +10 dB. Typically 10 dB lower. Permalloy shielding of sensitive components allows for external hum fields generated by ordinary laboratory instruments in close proximity.
Noise:	Dependent on setting of BANDWIDTH, F-dial and input attenuator; approx. -105 to -90 dB with no input signal, and a jitter on any signal of approx. -100 dB peak-to-peak at fast meter speed and lower at slow meter speed.
INPUT	
Impedance:	1 M $\Omega$ , 45 pF on all ranges. Unbalanced. 10 M $\Omega$ , 7 pF with Tektronix Probe. Balanced with optional Balancing Transformer, type BAT11. Transformer: 10 k $\Omega$ in major part of range.
RECORDER OUTPUT	
	About 1.8 V, 2 kc output at full deflection. Amplitude proportional to 10 dB overdrive at input. More than 80 dB dynamic range. 2 k $\Omega$ output impedance. Recording speed: Dependent on bandwidth setting and response of input signal. At harmonic analyses: 10 cps/sec to 3000 cps/sec depending on bandwidth setting.



## BEAT FREQUENCY OSCILLATOR

### FREQUENCY

Ranges: 10 cps-60 (63) kc and 10 cps-6 kc.  
Synchronously tuned by Analyzer F-dial or detuned by A = 0 to  $\pm 2$  kc from frequency F by auxiliary dial A.

Accuracy: Frequency F: 0.3% + 3 cps (typically 0.1% + 3 cps).  
Frequency A: 2% + 2 cps.

### OUTPUT VOLTAGE

Two ranges selected by pushbuttons:  
0 to 4 volts open circuit voltage or  
0 to 0.5 volts open circuit voltage. Both continuously variable by potentiometer, calibrated 0 to 1.

Accuracy: Better than 5%.

Output Impedance: 600  $\Omega$ .

Load: Any.

Frequency response: Within 1 dB from 10 cps to 60 kc;  
within 0.4 dB from 20 cps to 50 kc.

Harmonics: Less than -70 dB at max. output; about  
-90 dB at reduced output.

Hum: Less than -70 dB.

Residual h. f. Approx. -50 dB.

### REGULATION

0.5 dB rise of 1.3 V AGC (automatic gain control) input gives about 40 dB logarithmic compression of BFO output with a time constant of approx. 0.15 sec.

Input impedance of AGC socket: 10 k $\Omega$ .

### SUPERPOSITION

Facility exists for superposition of an external signal with frequency B on the internal signal with frequency  $|F + A|$  from the beat frequency oscillator.

The two signals are fed to their individual emitter-followers which both are connected to the output terminal via 1200  $\Omega$  resistors.

Input signals of emitter-followers:

External: 4 volts to B-FREQUENCY jack with 10 k $\Omega$  input impedance.

Internal: 1 volt from BFO with frequency  $|F + A|$   
 $F$  = reading on analyzer dial.  
 $A$  = reading on auxiliary dial (0 to  $\pm 2$  kc).

Output signals from  
 emitter-followers:

0 to 2 volts of signal B.  
 0 to 0.5 volts of signal  $|F + A|$ . Both signals are continuously and simultaneously variable by a linear potentiometer calibrated in multiplication factors 0 to 1.

Accuracy: Better than 5%.

Impedance: 600  $\Omega$ .

Load: Any.

Residual inter-modulation: Less than -100 dB (SMPTE) at max. output.

#### TERMINALS

Front Plate: All input and output terminals are UHF type SO239 coaxial sockets which also accommodate 4 mm banana plugs.

Rear Plate: 6 BNC connectors, one slide switch:

Input: 240 kc + 2F (F = dial reading), 4 k $\Omega$ .

Output: 240 kc + 2F, about 2 V rms from 25  $\Omega$  source.  
 Slide switch: INT-EXT. gives normal and slave analyzer operation.

Output: 120 kc + F, about 6 V (peak-to-peak) from 10 k $\Omega$  source.

Output: 120 kc - A, about 25 mV rms from 100  $\Omega$  source.

Output: 120 kc, approx. 30  $\mu$ V to approx. 30 mV at full deflection from 10 k $\Omega$  source. (Depending on METER RANGE setting).

Output: 118 kc, about 1 V rms from 10 pF source.

#### POWER SUPPLY

Voltages: 110, 115, 127, 200, 220, and 240 volts.

Line frequencies: 50 to 60 cps.

Consumption: 30 watts.

**MOUNTING AND  
FINISH**

Transistorized with Nuvistor input tube. Plug-in printed boards. Steel cabinet in grey enamel. The front panel is compatible with a 19" standard rack.

**OVERALL  
DIMENSIONS**

Height	Width	Depth
340 mm 13 1/2"	490 mm 19 1/2"	355 mm (405 mm with handles) 14" (15 3/4")

**WEIGHT**

37 kilos (81 lbs).

**ACCESSORIES  
SUPPLIED**

1 power cord, code 615-300, 1.7 m long.

**ACCESSORIES  
AVAILABLE**

Sweep Drive Gear Box, type SDG1, for chain drive from recorder. SDG1 is supplied with accessories enabling mechanical coupling to FRA3.

Cover, code 884-000, for Wave Analyzer, type FRA3 in standard 19" rack version.

Balancing Transformer: 1:1 type BAT11.

Coaxial cable, code 617-003, with 2 UHF PL259 plugs, 1 m long.

Coaxial cable, code 617-006, with 2 BNC type UG-88/U plugs, 1 m long, for slave analyzer operation.

Adapter, type AD1, for UHF coaxial socket, takes 14 mm coaxial plug.

## Section C. Accessories

### SWEEP DRIVE GEAR BOX, TYPE SDG1

As the Wave Analyzer, type FRA3, is not provided with a built-in gear box, a special Sweep Drive Gear Box, type SDG1, has been designed. The purpose of this box, which can be mounted on top of the Wave Analyzer, type FRA3, is to transfer the mechanical movement of a recorder output-shaft to the coarse shaft of the variable capacitor of the Analyzer. The recorder is assumed to have a horizontal output shaft parallel with the front panel of the Analyzer. A chain-wheel is mounted on the recorder output shaft (or a special adapt-

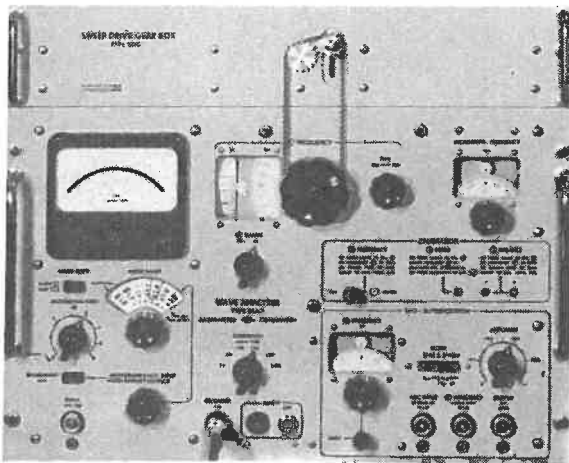

Fig. 3. The Sweep Drive Gear Box, type SDG1.

er with a chain-wheel may be used), and another chain-wheel is mounted on the input shaft of the gear box. The shaft movement is transmitted by means of a precision chain. In the gear box, a gear-and-pinion drive transmits the movement to an output shaft at right angles to the front panel. On the shaft, which is located just above the coarse shaft of the variable capacitor, a chain-wheel is mounted, and by means of a precision chain, the movement is transmitted to the capacitor shaft. The ordinary knob of the capacitor shaft must be replaced by a specially designed knob which includes a free-running chain-wheel. By means of a friction clutch the chain-wheel can be locked to the knob which is in rigid connection with the shaft. This implies that under locked conditions the capacitor is turned by the movement transmitted from the recorder. By unlocking the friction clutch (which is done simply by loosening a knurled screw in the knob), the capacitor can freely be turned without sacrificing the normal flywheel action to any appreciable degree. Once mounted on top of the Analyzer, it is not necessary to dismount the Sweep Drive Gear Box, type SDG1, if the Analyzer is to be used for manual operation.

The Sweep Drive Gear Box, type SDG1,

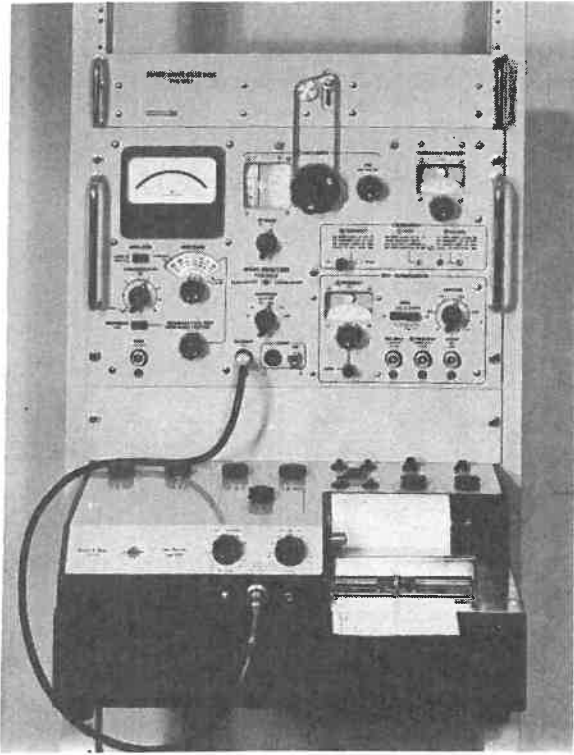

Fig. 4. The combination, Wave Analyzer, type FRA3, Sweep Drive Gear Box, type SDG1, and Brüel & Kjær Recorder, type 2305.

has been developed in order to adapt the Radiometer Recorder, type NS3, or the Brüel and Kjær Recorder, type 2305, to the Wave Analyzer, type FRA3.

The combination SDG1-FRA3-NS3 or 2305 can also be furnished as a rack assembly with all the necessary accessories, i.e. gear wheel adapter, chains, etc. In this case a Brüel & Kjær Conversion Kit, code LT0020, is necessary to transform the Standard Recorder, type 2305 to the rack version. It is also necessary to use a dust cover, code 884-000 for the Wave Analyzer, type FRA3.

For specifications of the Sweep Drive Gear Box, type SDG1, see tables 1 and 2 below.

Accessories supplied with Sweep Drive Gear Box, type SDG1

Code No. 900-091 consisting of:

Chain with 80 links:

Code No. 867-621

Tuning knob with chain wheel:

Code No. 852-402

INFA hexagonal wrench:

Code No. 013-915

INFA hexagonal wrench:

Code No. 013-920

INFA hexagonal wrench:

Code No. 013-925

3 washers, 6.1/15 x 0.5,

Code No. 043-320

Accessories available for connection of FRA3/SDG1 to a type 2305 Brüel & Kjær level recorder - table version.

Code No. 900-092 consisting of:

Chain wheel, 16 teeth, for input shaft of SDG1:

Code No. 867-624

Chain with 160 links between SDG1 and recorder:

Code No. 867-622

Chain wheel with coupling in threaded tubing UT0014:

Code No. 867-623

Coaxial cable, code 617-009, 1 m long, capacitance 45 pF. Terminated in one 14 mm plug and one UHF-type PL-259 plug.

3 rolls of recording paper for Brüel & Kjær Recorder, type 2305, calibrated for FRA3:

Code No. 984-034

FRA3 - SDG1 - BRUEL & KJÆR RECORDER, TYPE 2305

RECORDING SET-UP WITH:

FRA3 WAVE ANALYZER  
SDG1 SWEEP DRIVE GEAR BOX  
2305 BRUEL & KJÆR RECORDER

THE TABLE SHOWS:

RECORDING TIME  
FREQUENCY SPEED  
PAPER LENGTH  
RESOLUTION  
AT VARIOUS DRIVE SHAFT  
SPEEDS AND PAPER SPEEDS

TABLE 1

SPEED OF DRIVE SHAFT II OF 2305 REVOLUTIONS PER MINUTE	"F" DIAL SPEED OF FRA3 REVOLUTIONS PER MINUTE	TIME FOR A 0 TO 60 KC RECORDING MINUTES (20 REVOLUTIONS OF "F" DIAL)	FREQUENCY SPEED CPS PER SECOND	PAPER LENGTH OF A 0 TO 60 KC RECORDING IN METERS						RESOLUTION IN CPS PER MM PAPER							
				10	3	1	0.3	0.1	0.03	10	3	1	0.3	0.1	0.03		
120	20	1	1000	0.6	0.18	0.06						100	333	1000			
36	6	3.33	300	2	0.6	0.2	0.06					30	100	300	1000		
12	2	10	100	6	1.8	0.6	0.18	0.06				10	33.3	100	333	1000	
3.6	0.6	33.3	30	20	6	2	0.6	0.2	0.06			3	10	30	100	300	1000
1.2	0.2	100	10	60	18	6	1.8	0.6	0.18			1	3.3	10	33.3	100	333

FRA3 - SDG1 - NS3

RECORDING SET-UP WITH:

FRA3 WAVE ANALYZER  
SDG1 SWEEP DRIVE GEAR BOX  
NS3 LOGARITHMIC RECORDER

THE TABLE SHOWS:

RECORDING TIME  
FREQUENCY SPEED  
PAPER LENGTH  
RESOLUTION

AT VARIOUS CHAIN GEAR RATIOS  
OF CHAIN DRIVE BETWEEN RECORDER  
NS3 AND SWEEP DRIVE GEAR BOX SDG1

TABLE 2

NS3 DRIVE SHAFT SPEED REVOLUTIONS PER MINUTE	CHAIN GEAR RATIO NS3 TO SDG1	SDG1 GEAR RATIO INPUT - OUTPUT	CHAIN GEAR RATIO SDG1 - FRA3	RESULTING GEAR RATIO	"F" DIAL SPEED OF FRA3 REVOLUTIONS PER MINUTE	TIME FOR A 60 KC RECORDING IN MINUTES (= 20 REVOLUTIONS)	FREQUENCY SPEED CPS PER SECOND	NS3 PAPER SPEED: 5 MM PER SECOND			
								0-60 KC PAPER LENGTH IN METERS	RESOLUTION IN CPS/MM		
								NS3 PAPER SPEED: 1.25 MM PER SECOND			
								0-60 KC PAPER LENGTHS IN METERS	RESOLUTION IN CPS/ MM		
3	1:5	3:1	2:1	1.2:1	2.5	8	125	2.4	25	0.6	100
3	1:1	3:1	2:1	6:1	0.5	40	25	12	5	3	20
3	5:1	3:1	2:1	30:1	0.1	200	5	60	1	15	4

Accessories available for connection of FRA3/SDG1 to a type NS3 Radiometer table version recorder.

Code No. of complete set: 900-093

Chain wheel, 16 teeth, for input shaft of SDG1:

Code No. 867-624

Chain wheel, 80 teeth, for output shaft of NS3:

Code No. 867-627

Output shaft for NS3:

Code No. 866-005

Chain with 160 links between SDG1 and recorder:

Code No. 867-622

Coaxial cable, code 617-009, 1 m long, capacitance 45 pF

5 rolls of uncalibrated recording paper

Code No. 984-007

3 rolls of calibrated paper for 1 kc/cm

Code No. 984-034

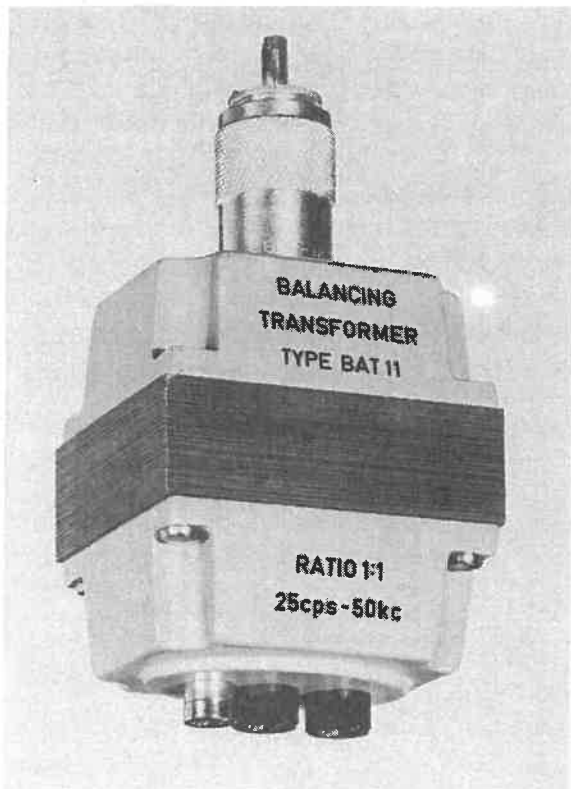

Fig.5. The Balancing Transformer, type BAT11.

Accessories available for Special Purposes.

Chain, open. Length by order:

Code No. 867-620

**BALANCING TRANSFORMER, TYPE BAT11**

The type BAT11 Balancing Transformer changes the one-side grounded input of an instrument to a balanced input. Type BAT11 is an audio-frequency type for use from 25 cps to 50 kc.

The transformer is furnished with the type PL-259 UHF plug. Therefore, it can be plugged directly into the input of the Wave Analyzer, type FRA3.

The Balancing Transformer is designed with special emphasis on frequency response, electrostatic shielding, and input impedance.

The input terminals accommodate 4 mm banana plugs.

**SPECIFICATIONS**

Voltage ratio:

1 to 1

Frequency Response:

25 cps to 50 kc within  $\pm 0.5$  dB

Input Impedance:

Higher than 10 k $\Omega$  throughout the frequency range, provided that the secondary load is less than 20 pF.

Shielding:

The mutual capacitance between the windings is less than 1 pF.

Symmetry:

Common-mode signal rejection:

90 dB at 500 cps

70 dB at 5 kc

45 dB at 50 kc

Magnetic Pick-Up:

When the primary is connected to a source with 300  $\Omega$  impedance, a typical case, the magnetic pick-up is approxi-



mately  $1 \mu\text{V}$  at optimal orientation of the transformer.

#### Insulation:

The dc leakage between the primary and the shield is less than  $5 \times 10^{-10}$  mhos. The working voltage is 250 V dc, and the test voltage is 1000 V dc.

#### Signal Voltage:

The input voltage should not exceed 100 V at frequencies above 250 cps and 0.4 V per cps below 250 cps.

#### Distortion:

With a 5 V input and a  $300 \Omega$  primary source impedance, the distortion is less than 0.2% 2nd and 0.2% 3rd harmonic above 100 cps; about 0.6% 2nd and 1% 3rd harmonic at 30 cps.

#### Dimensions:

54 by 45 mm ( $2 \frac{3}{16}$  by  $1 \frac{3}{4}$  in).

#### Over-all length:

117 mm ( $4 \frac{5}{8}$  in).

#### Weight:

500 grams (1 lb. 2oz).

## Section D. Operating Principle

### OPERATING PRINCIPLE OF THE ANALYZER

The operating principle of the Wave Analyzer is shown in the block diagram of Fig. 6. The Wave Analyzer operates on the heterodyne principle and double conversion with two different intermediate frequencies is used in order to obtain high selectivity in conjunction with variable bandwidth.

The input voltage is always fed to an INPUT ATTENUATOR which attenuates the signal so that the signal at the following INPUT AMPLIFIER never exceeds 100 mV. This amplifier feeds a signal current proportional to the input voltage via the BROADBAND switch and the 60 kc INPUT LOW PASS FILTER to the first MIXER. The mixer changes any (mixer) input signal in the frequency range from 0 cps to 60 kc to a 120 kc signal (among many others), if the F- OSCILLATOR is tuned by setting the F- FREQUENCY dial so that the input frequency is read. This 120 kc signal is proportional in amplitude to the input signal, and is fed, via the 120 kc I.F. BAND PASS FILTER and an EMITTER FOLLOWER, to a 30 dB ATTENUATOR. The attenuator gives 0 dB attenuation with the METER RANGE switch set to the four most sensitive settings, and 30 dB in the last three measuring positions.

The 120 kc signal then passes to the second MIXER and is here mixed with a signal from the 118 kc  $\pm 100$  cps OSCILLATOR, which can be tuned in a  $\pm 100$  cps range by the INCREMENTAL FREQUENCY dial.

The 2nd MIXER produces a 2 kc signal which is filtered in the following 2 kc BAND PASS FILTERS 1 and 2, which are interconnected by the 2 kc BUFFER AMPLIFIER.

The 2 kc signal from the 2nd BAND PASS FILTER is amplified in the following 1st 2 kc AMPLIFIER before it is fed to a 3 x 10 dB ATTENUATOR, and from there to the 2nd 2 kc AMPLIFIER.

Via the BROADBAND pushbutton switch, the 2 kc signal afterwards passes to the METER AMPLIFIER and is rectified in the rms RECTIFIER, which supplies the current to the meter.

When the BROADBAND button is pressed, the signal from the INPUT amplifier travels directly to the METER AMPLIFIER, and the sensitivity is then independent of the METER RANGE setting and equal to the extreme right-hand value on the METER RANGE dial. This reading depends only on the INPUT ATTENUATOR and the INCREMENTAL GAIN settings.

The RMS RECTIFIER senses only the rms value of a white noise input and a sinus-

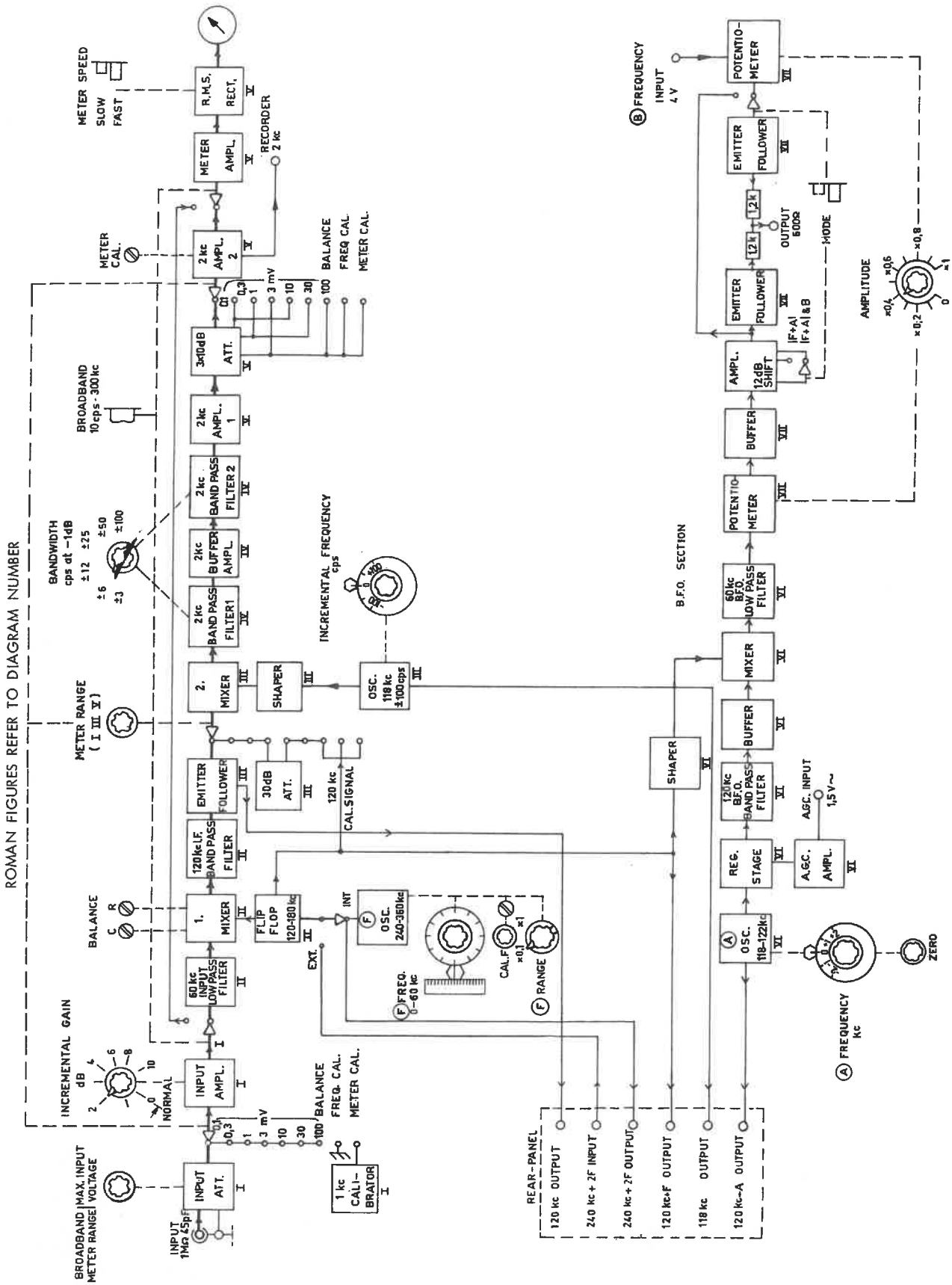

Fig. 6. Block diagram of the Wave Analyzer, type FRA3.

oidal input, so that a greatly distorted input voltage is not measured accurately with the BROADBAND button pressed.

The 2 kc output present at the RECORDER jack is taken from the 2nd 2 kc AMPLIFIER and is proportional to the meter deflection.

In its extreme right-hand position the METER RANGE switch feeds a calibrating voltage from the 1 kc CALIBRATOR to the INPUT AMPLIFIER, enabling a check of the overall sensitivity. In the extreme right-hand position but one, the F-OSCILLATOR signal, halved in the following FLIP-FLOP, is fed to the 2nd MIXER. With the F-FREQUENCY dial set to zero, this signal is tuned to 120 kc by means of the FREQUENCY CALIBRATION knob FINE (and screwdriver setting COARSE) so that the meter gives maximum (not full) deflection. With the METER RANGE in its last sensitive measuring range (0 dB RELATIVE), and with the F dial at zero, the disturbing 120 kc oscillator voltage penetrating the first MIXER can be balanced out by means of two screwdriver settings, BALANCE, C and R.

The F-OSCILLATOR has two ranges which are chosen by the knob F-RANGE  $\times 0.1$  -  $\times 1$ . In RANGE  $\times 1$ , the oscillator frequency varies between 240 kc and 360 kc, when the F-dial is tuned through its entire range. The oscillator voltage goes via a switch to the FLIP-FLOP stage driving the mixer. The FLIP-FLOP changes the frequency range to 120 kc-180 kc, providing for a measuring range from 0 (10 cps) to 60 kc.

With the F-RANGE switch set to position  $\times 0.1$  the oscillator range is 240 kc-252 kc, the FLIP-FLOP range is 120 kc-126 kc, and the measuring range is 0 (10 cps) - 6 kc.

If the switch INTERNAL-EXTERNAL on the back plate is set to EXTERNAL, an external generator can be used instead of the F-OSCILLATOR. Slave analyzer operation is thus readily provided for.

## OPERATING PRINCIPLE OF THE TONE GENERATOR

Also the tone generator section operates on the heterodyne principle.

The 120 kc-180 kc FLIP-FLOP voltage is fed via a SHAPER to a MIXER stage. The A-OSCILLATOR is also connected to the MIXER, but via a REGULATING STAGE, a 120 kc BFO BAND PASS FILTER and a BUFFER stage. The difference-frequency from the mixer lies in the range 0 to 60 kc with the A-FREQUENCY dial set to zero. With the ZERO knob properly adjusted, the frequency is exactly the same as the tuning frequency of the analyzer. The A-FREQUENCY dial reading gives the difference between the analyzer tuning and the BFO output frequency. The attenuation of the REG. STAGE, and consequently the BFO output, depends on the dc output voltage of the AGC AMPLIFIER.

If the ac voltage at the AGC INPUT jack is approx. 1.2 volts, the REG. STAGE starts operating and ceases when the AGC INPUT is approx. 1.5 volts.

The MIXER output is filtered in the 60 kc BFO LOW PASS FILTER and fed to the top of the tandem POTENTIOMETER - AMPLITUDE controlling the output amplitude. The adjustable voltage from the POTENTIOMETER passes to a BUFFER stage and thence to an AMPLIFIER STAGE which gives maximum 4 V to the EMITTER-FOLLOWER output stage when the MODE pushbutton |F + A| is pressed, and 1 V if the |F + A| & B pushbutton is pressed, resulting in a 0.5 V |F + A| open circuit voltage at the OUTPUT jack, due to the loading by the second EMITTER FOLLOWER. This loading is not present when the |F + A| button is pressed, because both EMITTER FOLLOWERS then are connected in parallel and the maximum BFO output in that case is 4 V. Superposition of an external signal fed to the B-FREQUENCY INPUT jack takes place if the |F + A| & B pushbutton is pressed, so that maximum half of the input voltage at the B-FREQUENCY INPUT is had at the OUTPUT

jack together with max. 0.5 V | F + A | signal.

Two of the six input and output jacks on the REAR PANEL are intended for slave analyzer operation, and the rest for connecting special equipment.

**CONTROLS, TERMINALS, AND METER OF THE ANALYZER**

As shown in Fig. 7, the Wave Analyzer, type FRA3, is equipped with the following controls and terminals:

Power Switch (OFF), and Pilot Lamp

Power switch and pilot lamp are located in the middle of the front panel.

Operating Controls of the Analyzer

Frequency Controls

The analyzer has the following three controls:

The main tuning dial F -FREQUENCY (1) either operated directly by the knob COARSE, or by means of the knob FINE, when engaged by pushing to position ON.

The INCREMENTAL FREQUENCY dial (2) alters the frequency of the second oscillator by max. ± 100 cps. The reading is independent of the setting of the main tuning dial.

The F -RANGE switch (3) gives the two multiplying factors 0.1 and 1 of the main dial reading.

Sensitivity Controls

The analyzer has four sensitivity controls:

The MAX INPUT VOLTAGE knob (4) controls the input voltage. It gives max. 70 dB attenuation in 10 dB steps and prevents overloading of the input stage. The dial is geared to the knob and part of it is visible in the METER RANGE window.

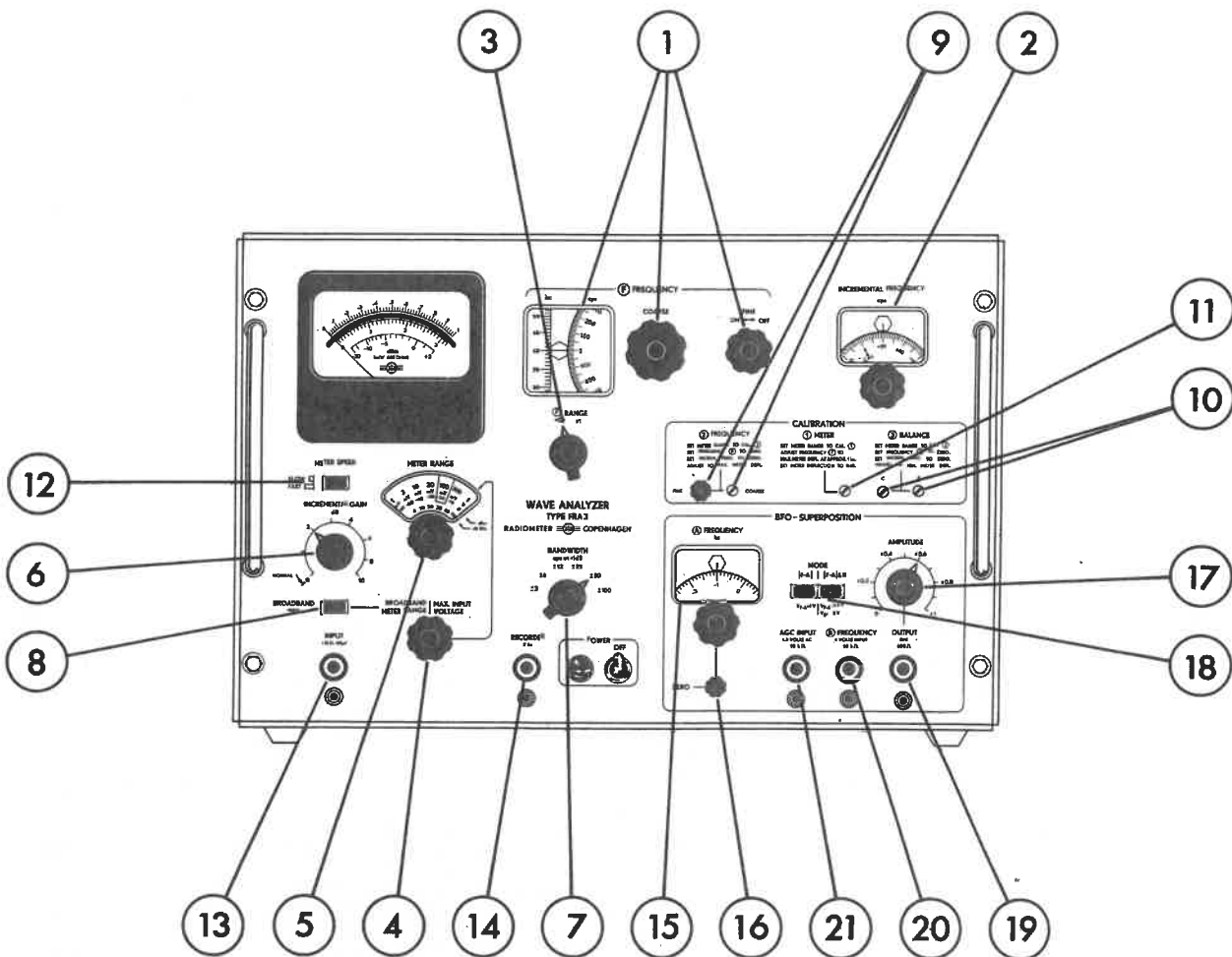

Fig.7. Front plate of the Wave Analyzer, type FRA3.

The reading at extreme right gives the maximum input voltage that can be tolerated if the residual distortion is to be lower than the warranted value. Otherwise a 10 dB rise in input voltage gives approximately a 10 dB rise in residual distortion.

The METER RANGE switch (5) enables a 60 dB rise in 10 dB steps of the sensitivity given by the max. input voltage reading.

The rise in sensitivity can be read from the dB REL. (relative) scale of the cursor dial, using the index spot on the lower edge of the window.

The INCREMENTAL GAIN Potentiometer (6) gives a rise in sensitivity of 0 to 10 dB continuously adjustable and is calibrated at 0 and 10 dB.

All METER RANGE readings are direct when the potentiometer INCREMENTAL GAIN is set at 0 dB-NORMAL.

#### Bandwidth Controls

The BANDWIDTH switch (7) selects one of the six bandwidths:  $\pm 3$ ,  $\pm 6$ ,  $\pm 12$ ,  $\pm 25$ ,  $\pm 50$  and  $\pm 100$  cps, giving the -1 dB points on the selectivity curves which are all flat-topped.

The switch varies the coupling and damping of the two band-pass filters tuned to the second intermediate frequency of 2 kc.

The BROADBAND pushbutton (8) converts the analyzer into an untuned millivoltmeter, when pressed. The sensitivity is 100 mV to 300 V full scale in 10 dB steps with INCREMENTAL GAIN at zero irrespective of the METER RANGE setting.

#### Calibration Controls

The knob FREQUENCY FINE (9) and the screwdriver setting COARSE (9) tune the oscillator frequency to 240 kc when the F-dial is set to zero and the METER RANGE dial is set to the extreme right-hand position but one, -F-, provided that the second oscillator is at 118 kc (INCREMENTAL FREQUENCY dial at zero). The

two variable capacitors in question are connected in parallel to the main tuning capacitor:

The two BALANCE controls C and R (10) set the 120 kc input at the second mixer (originating from the F-oscillator with dial at zero) to a minimum with the METER RANGE switch set to 0 dB REL., or to a more sensitive position if a very fine balance is wanted to enable measurements of very low voltages at frequencies lower than 20 cps.

The METER screwdriver setting (11) adjusts the sensitivity to the correct value when the METER RANGE switch is in its extreme right-hand position, M. An exactly known input voltage of approx. 1 kc is then fed from the built-in square-wave oscillator.

#### Meter Control

The METER SPEED pushbutton (12) gives a fast meter response when released, and a slow meter response when pressed, whereby quieter reading is obtained in noise measurements.

#### Terminals

##### Input terminal

The INPUT terminal (13) has an impedance of 1 M $\Omega$  in parallel with 45 pF for all settings of the input attenuator, BROADBAND METER RANGE/MAX. INPUT VOLTAGE, and for all settings of the INCREMENTAL GAIN potentiometer.

The terminal is a UHF type SO239 coaxial socket which also can accommodate a 4 mm banana plug, or a 14 mm or 13 mm coaxial plug when used in connection with the type AD1 or AD2 adapters.

##### Recorder terminal

The RECORDER output terminal (14) carries a 2 kc voltage of approx. 1.8 V at full-scale deflection with a source impedance of approx. 2 k $\Omega$ . The maximum voltage is 6 V which can be obtained with

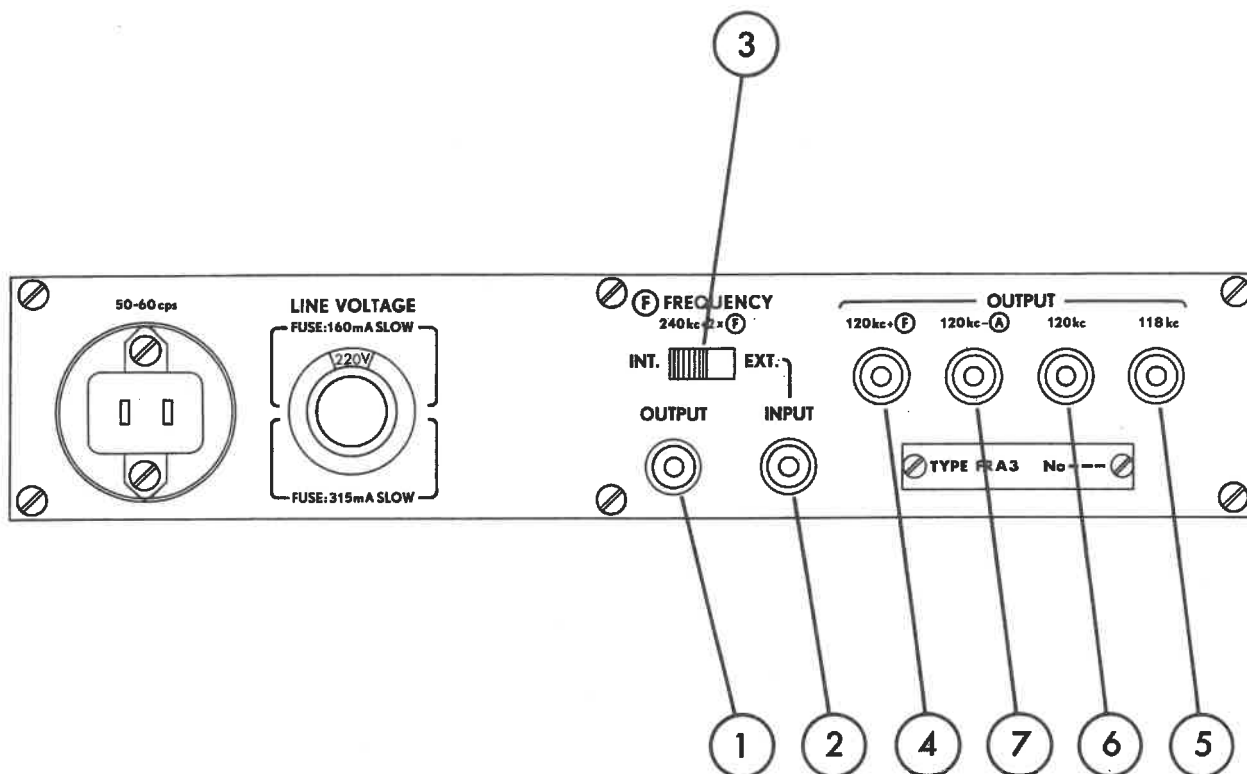

Fig.8. Rear panel of the Wave Analyzer, type FRA3.

10 dB overdrive at the input. The dynamic range is then greater than 80 dB, typically 85 dB.

#### Rear terminals

The six rear panel terminals are all of the BNC type (See Fig.8). The terminal, 240 kc + 2 F OUTPUT (1), always carries the F-oscillator voltage independently of switch settings. About 3 V rms are available from a 25  $\Omega$  source.

The terminal, 240 kc + 2 F INPUT (2), is free when the analyzer is operating in the normal way, but is connected to the flip-flop oscillator when switch (3) on the rear panel is set to position EXT. An input voltage of approx. 2 V rms is sufficient for driving the flip-flop oscillator. The input impedance is 4 k $\Omega$ .

The terminal, 120 kc + F OUTPUT (4), carries the flip-flop signal which also passes to the first mixer. The output voltage is almost square-waved in shape, and its magnitude is approx. 6 V peak-to-peak. The source impedance is 10 k $\Omega$ .

The terminal, 118 kc OUTPUT (5), carries a signal of approx. 1 V from the second oscillator. The frequency can be altered by  $\pm 100$  cps with the INCREMENTAL FREQUENCY dial. The output impedance is approx. 10 pF. Loading the terminal requires a recalibration of frequency.

The terminal, 120 kc OUTPUT (6), carries the input signal of the second mixer. The output voltage depends on the meter deflection and on the setting of the METER RANGE switch, and it lies between 50  $\mu$ V and 50 mV full deflection. The output impedance is 10 k $\Omega$ .

The terminal, 120 kc - A-OUTPUT (7), carries a signal of 25 mV from the A - FREQUENCY oscillator of the beat-frequency oscillator. The frequency lies between 118 and 122 kc. The output impedance is 100  $\Omega$ .

#### OPERATING CONTROLS OF THE BFO

As shown in Fig.7, the BFO section of

the Wave Analyzer is equipped with the following controls and terminals:

#### Frequency controls

The beat-frequency oscillator has three frequency controls:

The main frequency dial is the F-FREQUENCY dial of the analyzer section.

The A -FREQUENCY dial (15), which determines the detuning of the oscillator output frequency against the tuning frequency of the analyzer section.

The A -FREQUENCY, ZERO knob (16), which tunes the oscillator output frequency to be exactly the same as the analyzer tuning frequency, when the A - FREQUENCY dial is set to zero.

#### Output controls

The beat-frequency oscillator section has two output controls. The AMPLITUDE potentiometer (17) gives a continuous control of the output voltage and is calibrated in terms of multiplying factors.

The MODE pushbutton (18) determines the maximum output voltage obtained and provides for superimposing a signal from an external generator on the beat-frequency oscillator output, when the |F + A| & B button has been pressed.

#### Terminals

##### Output terminals

The output terminal of the beat-frequency oscillator (19) has an impedance of  $600 \Omega$  in series with  $50 \mu\text{F}$ . The dc resistance to chassis is  $100 \text{ k}\Omega$ .

The terminal is a UHF type SO-239 socket as all front panel terminals of the instrument.

##### Input terminals

The B -FREQUENCY input terminal (20) takes the signal from an external oscillator and feeds it to the superposition amplifier, if the |F + A| & B MODE push-

button has been pressed. The input impedance is  $10 \text{ k}\Omega$ . If 4 V from a  $10 \text{ k}\Omega$  source are present at the terminal, the ratio between the B-signal and the internal BFO signal is 4 to 1 at the input terminal for all settings of the AMPLITUDE control.

The AGC INPUT terminal (21) takes any signal in the frequency range from approx. 30 cps to 100 kc. The input impedance is  $10 \text{ k}\Omega$ , and if the input voltage is raised to approx. 1.2 V, the regulation starts, and the total regulating range (-60 dB) is traversed for a rise in input voltage of approx. 1 dB.

#### METER

The meter is equipped with a mirror-backed scale and a knife-edge pointer providing for accurate reading free from parallax. It has three scales of which the two upper ones are used when measuring voltage, the reading being given directly in rms millivolts or volts. The lower scale is used for relative measurements and is graduated in decibels. The mechanical zero screw is located on the meter itself.

The moving coil is taut-band suspended.

#### LINE VOLTAGE RECEPTACLE, FUSE, AND VOLTAGE SELECTOR

As seen in Fig. 8, all three are located on the rear of the instrument. Use 1 160 mA slow-blow fuse for a line voltage between 200 and 240 volts and a 315 mA for 110 - 127 volts operation. The Wave Analyzer, type FRA3, is set to a line voltage of 220 volts when leaving the factory and is furnished with 2 corresponding fuses.

To switch to another line voltage, proceed as follows:

First unscrew the center screw, then withdraw the disc; next rotate it until the desired line voltage is visible, and finally remount it and tighten the center screw.



## Section E. Operating Instructions

### GENERAL

The accuracy obtained when measuring the harmonics generated by an instrument under test - e.g. an amplifier - is dependent on the amplitude of the harmonic under measurement and on the residual distortion of the analyzer.

The three components of a certain harmonic present in the tone generator, the apparatus under test, and the analyzer, are added up as vectors, and the sum is thus dependent on their phase relation.

A low-distortion generator and analyzer are therefore of importance if high accuracy is wanted, and if the inconvenience of filtering the tone generator output and the analyzer input is to be avoided.

If the input signal to the amplifier under test is taken from the BFO output of a second FRA3, 1 volt is obtainable with approx. 0.003% second harmonic and with the higher harmonics at a lower level.

The typical residual second harmonic of the wave analyzer is 0.002%, and the higher harmonics are at a lower level.

The second harmonic of the amplifier under test lies, therefore, somewhere between  $h\% - 0.005\%$  and  $h\% + 0.005\%$ , if  $h$  is the value measured.

The higher harmonics are measured with greater accuracy than the second.

### STEP-BY-STEP OPERATION

#### 1. Calibration

- 1) Connect the analyzer to the line and to the apparatus under test; then allow it to warm up for some minutes.
- 2) Set F-RANGE switch to position  $\times 1$ , or to position  $\times 0.1$  if frequencies higher than 6 kc are of no interest.
- 3) Make sure that the rear panel switch is set to position INT.
- 4) Set METER RANGE switch to -F- (extreme right-hand position but one).
- 5) Set F-FREQUENCY dial to zero.
- 6) Set INCREMENTAL FREQUENCY dial to zero.
- 7) Set BANDWIDTH switch to  $\pm 3$  cps and METER SPEED to FAST.
- 8) Adjust FREQUENCY FINE, CALIBRATION knob (and COARSE setting, if necessary) for greatest possible meter deflection.
- 9) Set METER RANGE switch to position 0 dB REL.
- 10) Adjust the BALANCE controls C and R for minimum meter deflection ( $< 1$  mV).

Set BFO AMPLITUDE to zero or A-FREQUENCY dial off zero if an optimum in balance is wanted in order to make low-level measurements possible at low frequencies.

- 11) Set METER RANGE switch to M (extreme right-hand position).
- 12) Adjust F-FREQUENCY dial to max. meter deflection at approx. 1 kc.
- 13) Adjust the meter deflection to 0 dB by means of the screwdriver-operated METER control.

As a rule the sensitivity drifts only about 1% during the warmup time and it is therefore seldom necessary to repeat steps (11), (12) and (13).

## 2. Absolute Amplitude Measurements

- 1) Calibrate the sensitivity as explained in (11), (12), and (13) of section 1 above.
- 2) Calibrate frequency dial, too, (section 1 (3) to (8)) if max. frequency accuracy is needed.
- 3) Calibrate frequency dial and adjust BALANCE, too, if measurements at low frequencies (10 to 300 cps) are to be made.

Unbalanced oscillator signal should be lower than minus 40 dB REL if a 100  $\mu$ V - 10 cps voltage is to be measured.

Set A-FREQUENCY dial off zero or AMPLITUDE at ZERO in order to prevent "low frequency cross-talk" between BFO section and analyzer section. This makes the setting of BALANCE easier.

- 4) Set INCREMENTAL GAIN to NORMAL.
- 5) Set METER RANGE switch to 0 dB REL. (use the index spot on the lower edge of the METER RANGE window).

6) Press BROADBAND

7) Adjust BROADBAND METER RANGE knob so that a deflection of at least one third of maximum is obtained, if possible. If not, set the knob so that the extreme right-hand reading (MAX: INPUT VOLTAGE) in the METER RANGE window is 100 mV.

- 8) Release BROADBAND pushbutton.
- 9) Tune the analyzer to the desired frequencies by means of the F-FREQUENCY knobs COARSE and FINE.
- 10) Use the  $\pm 3$  cps BANDWIDTH setting when tuning to a low frequency (10 cps to 100 cps) and when measuring components with a very small frequency difference, or signals of a few microvolts.

Otherwise use a greater bandwidth in order to facilitate the tuning.

The disturbance of signals of a few microvolts from "spurious" (of same magnitude) is easily avoided by detuning the F-dial so little that the signal deflection is not influenced, but so much that the "spuriously" generated 2 kc I.F. signal is altered sufficiently in frequency so that a heavy attenuation is had in the 2 kc filters. This is possible because almost all the "spurious" are generated by very high harmonics of the oscillators.

Disturbance from "low harmonic spurious" is avoided by shifting the first I.F. slightly by means of the INCREMENTAL FREQUENCY dial and retuning the F-dial.

11) Use the METER RANGE switch to raise the sensitivity, if the meter deflection is too small. DO NOT TOUCH the knob MAX. INPUT VOLTAGE/BROADBAND METER RANGE or the INCREMENTAL GAIN knob; otherwise the residual distortion will rise.

If an increase in residual distortion of approx. 10 dB can be tolerated, a 10 dB rise in input is allowable, but not more. The rise in input can be made either by means of the INCREMENTAL GAIN potentiometer or by means of the MAX. INPUT voltage knob.

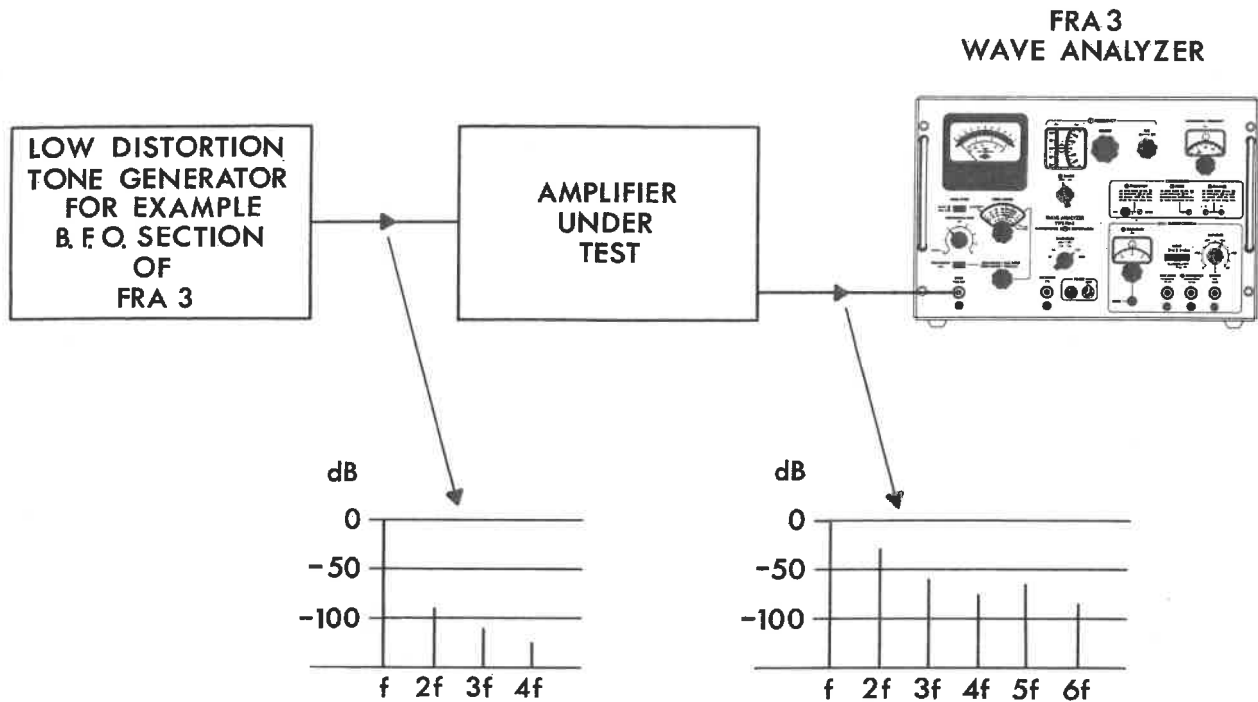

Fig. 9. Relative amplitude measurements (harmonic analyses).

12) Set A-FREQUENCY dial off zero in order to prevent "H. F. cross-talk" disturbance, if components of a few microvolts are to be measured.

### 3. Relative Amplitude Measurements

1) Calibrate frequency dial if max. frequency accuracy is wanted.

2) Adjust BALANCE settings if measurements of low frequencies are to be made. (A-FREQUENCY dial off zero).

3) Set METER RANGE to 0 dB REL.

4) Press BROADBAND pushbutton.

5) Set BROADBAND METER RANGE and INCREMENTAL GAIN knobs so that full meter deflection is obtained. At least 30 mV are necessary.

6) Release BROADBAND pushbutton.

7) Set BANDWIDTH to  $\pm 100$  cps if the input frequencies are unknown, and spin the F-FREQUENCY dial through the 1 kc to 60 kc range, searching for the strong-

est component. In harmonic analysis, this generally will be the fundamental. If the strongest component (generally approaching the BROADBAND amplitude) is not found in the 1 to 60 kc range, choose a smaller bandwidth and search for it below 1 kc at reduced tuning speed. If it is not found there either, it lies outside the tuning range.

8) Readjust to full meter deflection at the fundamental frequency by means of the INCREMENTAL GAIN potentiometer.

9) Measure the individual harmonics by tuning the Analyzer to a frequency 2, 3, 4, 5, . . . . n times the tuning frequency of the fundamental.

10) Use only the METER RANGE switch in order to get a sufficiently high deflection on weak signals. The sensitivity can be raised by 60 dB max. in 10 dB steps.

11) Read the amplitude in % on the two upper meter scales.

The uppermost scale gives: 100%, 10%, 1% and 0.1% full scale.

The middle scale gives: 30%, 3% and 0.3% full scale.

If the fundamental is set to 0 dB instead of to full deflection, the level of the harmonic, expressed in dB, is obtained by adding the meter scale dB reading to the negative dB REL. reading of the METER RANGE window (negative sign is omitted because of lack of space).

#### 4. Beat Frequency Oscillator Operation

1) Calibrate the analyzer section (see section 1).

2) Set MAX. INPUT VOLTAGE dial reading to e.g. 3V.

3) Set METER RANGE cursor to 3V.

4) Set A-FREQUENCY dial reading to 0 kc.

5) Press pushbutton: MODE | F + A |

6) Set AMPLITUDE potentiometer to e.g.  $\times 0.8$ .

7) Connect OUTPUT terminal of the BFO to INPUT terminal of the Analyzer tuned to e.g. 1 kc.

8) Adjust ZERO knob of A-FREQUENCY dial so that max. deflection is obtained on the meter. The BFO output voltage is  $4 \times 0.8 = 3.2$  volts.

The Analyzer and the BFO are now synchronized throughout the entire frequency range.

9) Disconnect the Analyzer INPUT terminal.

10) Connect the BFO output to the input of the apparatus under test.

If this is a filter with a characteristic impedance different from  $600 \Omega$ , then the output impedance of the BFO must be changed by resistors to match the filter, which also must be loaded properly at its output.

11) Connect the output of the apparatus under test to the INPUT of the Analyzer.

12) Adjust the output voltage of the BFO to the required level. If a level below 0.5 volts is needed, press the | F + A | & B MODE pushbutton.

13) Set METER RANGE and MAX. INPUT VOLTAGE controls of the Analyzer so that a convenient deflection is obtained.

14) Use the  $\pm 3$  cps bandwidth if low-level measurements are made, in order to reduce the influence of noise.

Use shielded cables at low-level measurements in order to secure grounding and to avoid high-frequency pick-up from strong oscillators and transmitters. (T.V. transmitters can give rise to components lying at the frequencies of the synchronizing signals of the TV transmitter (e.g. 50 cps and 15625 cps) if the input leads have the proper length to form a tuned antenna).

15) Connect the BFO OUTPUT terminal with the AGC INPUT terminal if a low impedance source is wanted.

The output voltage must be set to 4 volts. The AGC (automatic gain control) reduces the output voltage to approx. 1.3 volts. Consequently, the regulation (AGC action) takes place only if the voltage across the load is somewhat higher (e.g. 2 volts) before the AGC terminal is connected.

16) Rotate the F-dial through the desired frequency range and determine the response of the apparatus under test.

At frequencies lower than 20 cps, "cross-talk" occurs between the BFO section and the Analyzer section (via the "ripple" voltage of the tube filament), giving a lower measuring limit of  $30 \mu\text{V}$  at 20 cps (dependent on tube specimen) and higher at lower frequencies. The "cross-talk" is approx.  $-90$  dB at higher frequencies.

### 5. Intermodulation Measurements (SMPTE Method)

- 1) Calibrate analyzer (see section 1).
  - 2) Calibrate BFO section (see section 4).
  - 3) Connect OUTPUT terminal with INPUT terminal.
  - 4) Press |F + A| & B MODE pushbutton.
  - 5) Set potentiometer AMPLITUDE to x 1.
  - 6) Measure the output voltage (0.5 volts) with A -FREQUENCY dial set to zero and F -FREQUENCY dial off zero (e.g. at 5 kc).
  - 7) Connect an external audio-frequency generator with an internal impedance of 10 k $\Omega$  to the B -FREQUENCY input terminal and set the frequency to a value between 20 cps and 2000 cps as determined by the apparatus under test.
  - 8) Set A -FREQUENCY dial off zero.
  - 9) Tune analyzer to B -FREQUENCY.
  - 10) Adjust output of B -FREQUENCY generator so that the analyzer meter shows a voltage (2 V) that is exactly 4 times the first measured voltage of approx. 0.5 volts (see 6).
- The relation 1 to 4 will now hold for all settings of the AMPLITUDE knob.
- 11) Connect the apparatus under test to the BFO OUTPUT terminal and to the analyzer INPUT terminal.
  - 12) Adjust the OUTPUT voltage to the level claimed by the apparatus under test. If the 2 volts + 0.5 volt maximum output voltage is too low and has to be amplified, make sure that the amplifier employed has sufficiently low intermodulation.
  - 13) Press BROADBAND pushbutton and set MAX. INPUT voltage knob and INCREMENTAL GAIN knob so that the meter deflects to the 0 dB line. Release the pushbutton.
  - 14) Set F -FREQUENCY dial to a frequency other than B.

15) Make sure that the meter deflection is minus 12 dB when: METER RANGE is set to 0 dB REL., A -FREQUENCY is set to zero and A-ZERO is adjusted for maximum deflection.

16) Set the A -FREQUENCY dial so that the dial reading is plus or minus B. Increase the sensitivity with METER RANGE knob until an (intermodulation) deflection is had, and adjust the A-dial (or A-ZERO) to maximum deflection.

The BANDWIDTH setting depends on the B -FREQUENCY. A low B-frequency calls for a narrow bandwidth and so does a low intermodulation level.

17) Read the intermodulation side-frequency of first order by adding the (negative) dB REL. reading of the METER RANGE dial (the minus sign is omitted because of lack of space) to the dB reading on the meter dial.

Reduce the figure by 12 dB in order to get the SMPTE figure for the side-frequency of first order.

Measure the other side-frequency by tuning the A -FREQUENCY dial to opposite sign. The tuning of the A -FREQUENCY dial (or the external B -FREQUENCY oscillator) is correct when the intermodulation voltage is maximum.

18) Rotate F -FREQUENCY dial through the entire range and determine the variation in intermodulation.

The maxima at multiples of the fixed B -FREQUENCY are due to harmonic distortion in the B-input signal and harmonic distortion in the apparatus under test. Proper filtering of the B-signal, if necessary, gives the distortion of the apparatus under test.

19) Measure the intermodulation side-frequencies of second order by setting the external B -frequency to the A -frequency value divided by two or by doubling the A-reading. The two possible A -frequency settings (of opposite sign) give the two side-frequencies.

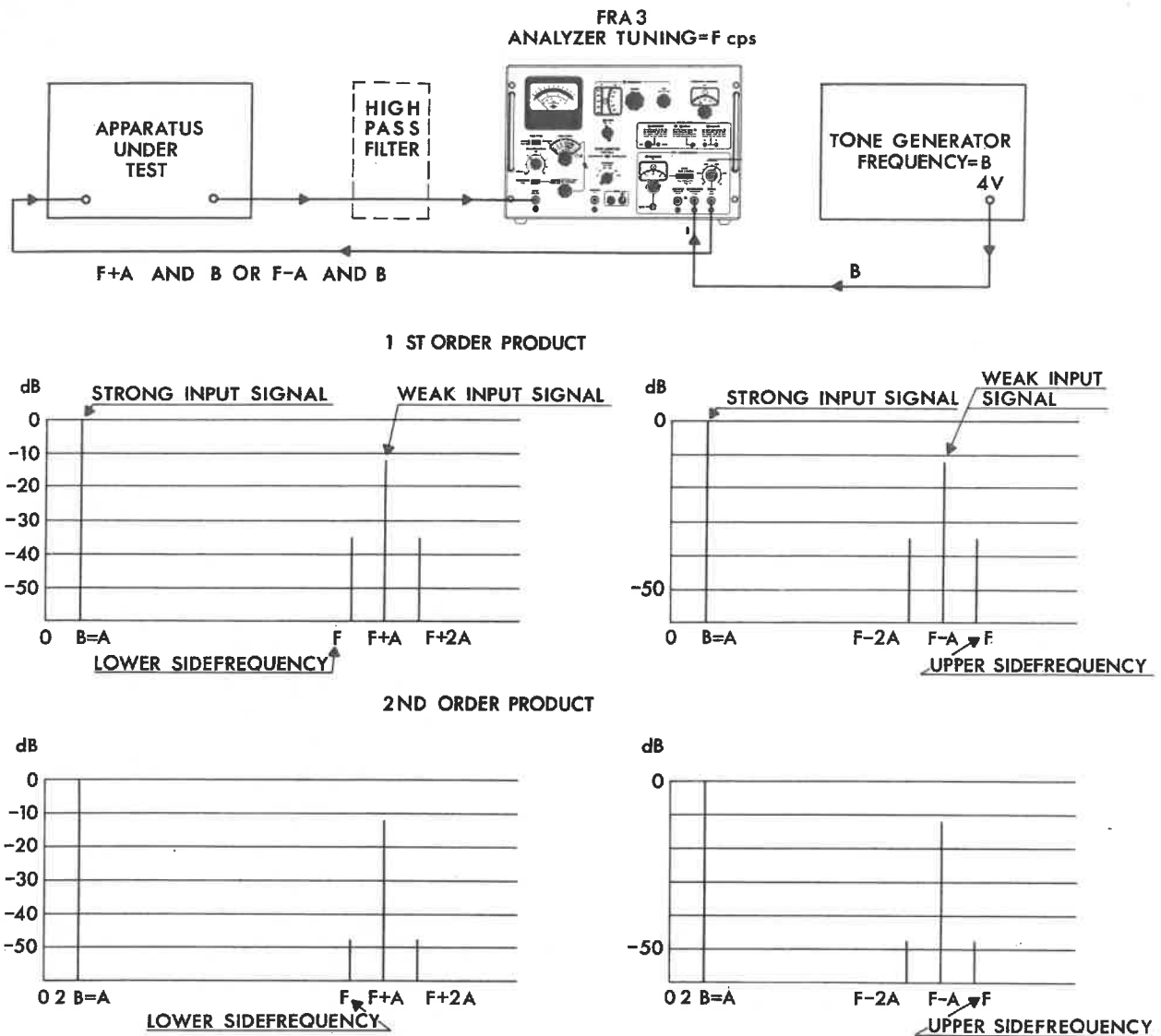

Fig.10. Intermodulation measurements of 1st and 2nd order according to the SMPTE method.

20) Insert a high-pass filter (between the output of the apparatus under test and the INPUT terminal of the analyzer) that attenuates the B -frequency component by somewhat more than 12 dB, if the intermodulation is very low. The filter allows for a 12 dB rise in analyzer sensitivity without a rise in residual distortion in the analyzer over the guaranteed value.

The  $|F + A|$  frequency signal must then give 0 dB meter deflection, if A- is

made zero (METER RANGE at 0 dB REL.).

The measuring range is the pass-band of the high-pass filter, and readings outside the pass-band, at too low frequencies, are not correct.

21) If the intermodulation factor is needed at a certain frequency F, tune the analyzer to F. Measure and note as many side-frequencies as wanted by setting the A-FREQUENCY dial to  $\pm B$ ,  $\pm 2B$ ,  $\pm 3B$ , ..., where B is the frequen-

cy of the external oscillator.

Fine tuning is possible by means of the INCREMENTAL FREQUENCY dial.

If the amplitudes of the upper and lower side-frequencies are designated

$a_1, a'_1, a_2, a'_2, a_3, a'_3, \dots$  and so on, the intermodulation factor is:

$$m = \frac{\sqrt{(a_1 + a'_1)^2 + (a_2 + a'_2)^2 + \dots}}{a_0}$$

where  $a_0$  is the amplitude of the signal  $F \pm A$  from the BFO section.

The frequency of this signal is in fact changed a little every time a new side-frequency is measured, because the intermodulation product in each instance is compelled to lie at the tuning frequency  $F$  of the analyzer. But if the response of the circuit under test is

reasonably flat, the difference between the amplitudes ( $a_0$ ) of  $F$  and  $F \pm n B$  is of no importance.

6. Intermodulation Measurements According to the C.C.I.F. Method

1) Connect two oscillators to the input of the amplifier under test in such a way that the intermodulation between them is sufficiently low.

If the intermodulation at the input of the amplifier under test is 20 dB lower than the intermodulation at the output, a measuring accuracy of 10% is secured, provided that the residual intermodulation of the analyzer (approx. -90 dB) is sufficiently low.

The problem of intermodulation between the two oscillators is easily solved if a second FRA3 Wave Analyzer is available. The BFO signal of the analyzer can be superimposed on a signal from

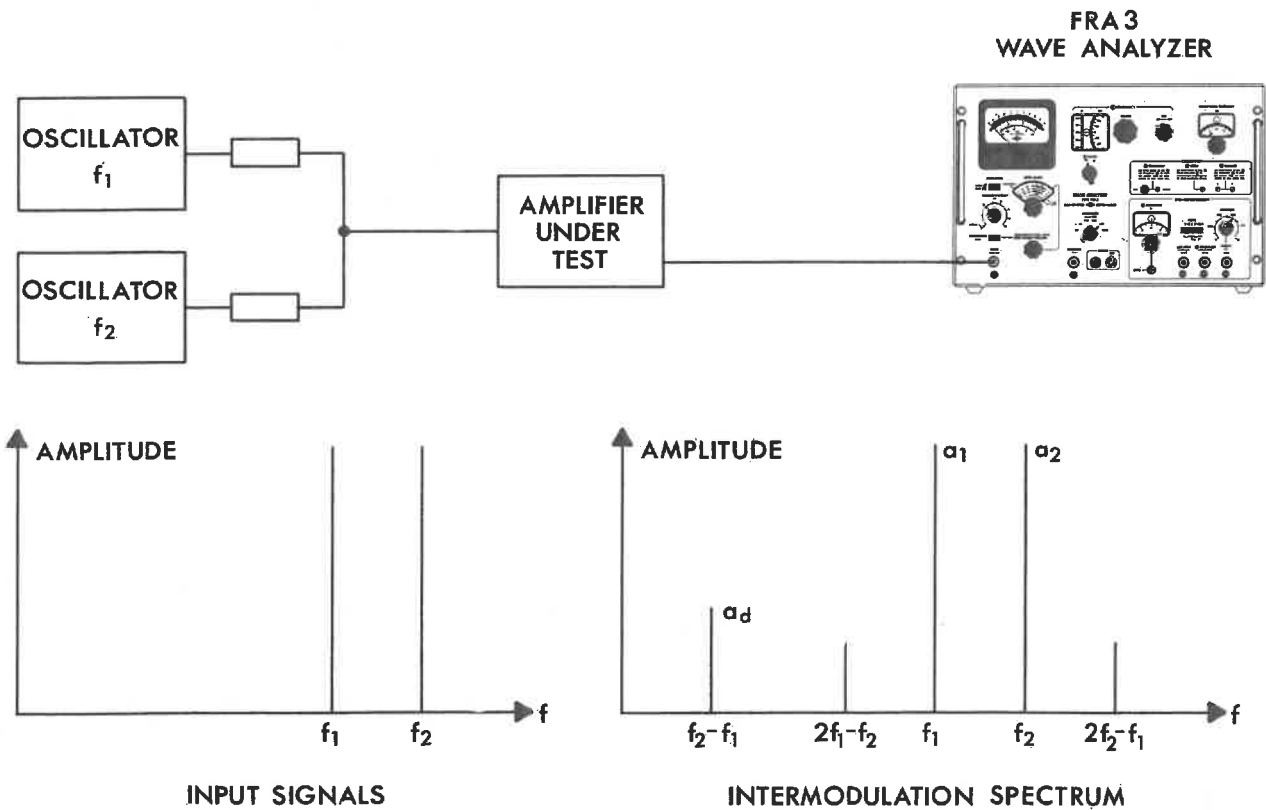

Fig.11. Intermodulation measurements according to the CCIF method.

an external oscillator (1 V rms). The superposition amplifier then supplies the two frequencies with equal amplitudes, adjustable between 0 and 0.5 volts. The intermodulation between the signals is more than 100 dB down.

2) Adjust the two input signals to the same appropriate value.

3) Measure the two signals at the output of the amplifier under test and also the amplitude of the intermodulation product at their difference-frequency component by means of the Wave Analyzer.

The percentage of CCIF intermodulation is then:

$$d_i = \frac{a_d}{a_1 + a_2} \times 100$$

where  $d_i$  = intermodulation

$a_d$  = amplitude of difference-frequency component

$a_1$  = amplitude of signal No.1

$a_2$  = amplitude of signal No.2

## 7. Noise Measurements

1) Adjust the analyzer.

2) Connect the noise source to the input of the analyzer. Use a shielded cable and do not place apparatus near by that generate strong external fields (line transformers, heavy audio output transformers, choke coils, etc.).

3) Choose a proper BANDWIDTH setting. Be sure to use the narrowest bandwidth when measuring at low frequencies in order to avoid an error from the (small) unbalanced oscillator signal at the first mixer. A very carefully set BALANCE enables noise measurements down to approx. 10  $\mu$ V at 30 cps. The noise bandwidths are exactly 1.04 times the 3 dB bandwidth. The 3 dB bandwidths are: 9 - 18 - 36 - 72 - 144 and 288, typically. The exact values are easily found by

means of the 0-6 kc dial with an input of 1 kc, which provides for low backlash.

4) Tune F -FREQUENCY dial to the frequency of interest.

5) Set METER SPEED pushbutton to position SLOW in order to reduce the fluctuations and to obtain a fair estimate of the average deflection.

The meter rectifier senses the rms value of a noise spectrum. All stages can tolerate a sinusoidal overdrive of 10 dB. Accurate measurements are thus ensured.

The residual noise of the analyzer is approx. minus 90 dB at  $\pm 100$  cps bandwidth (-105 dB at  $\pm 3$  cps bandwidth) for frequencies higher than 1 kc, except at maximum sensitivity (MAX. INPUT VOLTAGE reading: 100 mV), where the noise of the 1 M $\Omega$  and 45 pF input impedance may contribute, if the external source impedance is high enough. This contribution decreases with increasing frequency, and it is scarcely detectable at 10 kc. At 20 cps and  $\pm 3$  cps bandwidth the noise is approx. 1.5  $\mu$ V.

## 8. Slave Analyzer Operation

1) Connect the 240 kc + 2 F -OUTPUT terminal on the rear panel of the "master" analyzer to the 240 kc + 2 F INPUT terminal of the slave analyzer.

2) Calibrate both analyzers.

3) Set the switch F-FREQUENCY 240 kc + 2 F of the slave analyzer to position EXT.

4) Feed the same signal to both analyzers and tune the master to the frequency of the signal by means of the F-FREQUENCY dial.

5) Tune the slave analyzer by means of the INCREMENTAL FREQUENCY dial.

6) Connect the INPUT terminals of the two analyzers to the two sources in question needing a selective measuring channel.



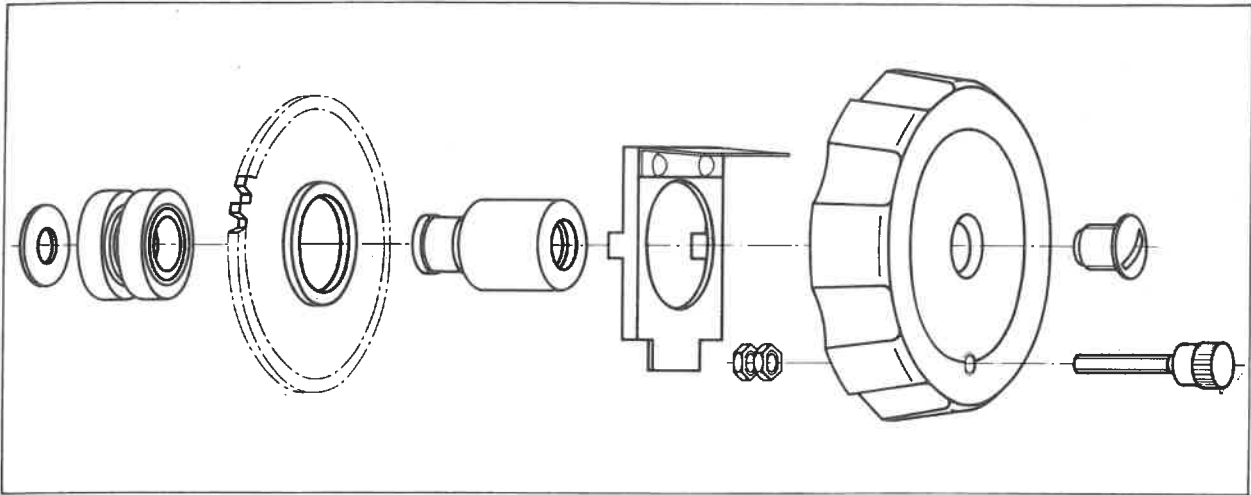

Fig.12. Disassembled frequency knob of the Wave Analyzer, type FRA3.

### 9. Recording.

1) Remove the two plug buttons on the top of the analyzer cabinet.

2) Place the Sweep Drive Gear Box, type SDG1, on the analyzer so that the two rubber knobs on its base fit into the plug button holes.

3) Lock the gear box firmly to the cabinet by turning the heads of the two expanding screws clockwise while pressing downwards until a faint click is heard

(release by pressing and turning counter-clockwise).

4) Unscrew the black nylon screw in the middle of the F-FREQUENCY dial knob and remove knob.

5) Remove the metal insert now visible by unscrewing the two grub screws. (See Fig. 12).

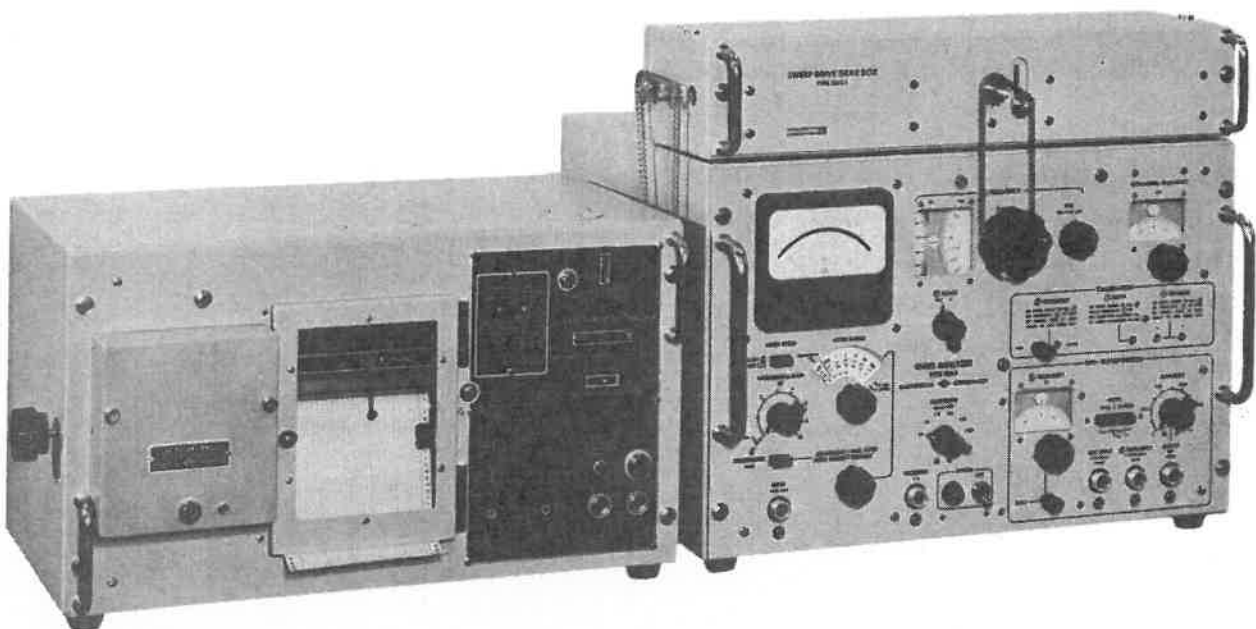

Fig.13. The Wave Analyzer, type FRA3, coupled to the Logarithmic Recorder, type NS3, via the Sweep Drive Gear Box, type SDG1.

6) If needed mount one, two or all three bronze washers (code No. 043-320) to ensure that the chain between the Sweep Drive Gear Box and the Analyzer does not touch the front plate when the chain is mounted on the free-running chain wheel. Mount the metal insert carrying the chain wheel tightly against the bronze washer(s) and afterwards the large knob with the screw-operated spring clutch. Make sure that the knob runs freely when the clutch is released (even if the chain-wheel is stopped).

7) Loosen the idling wheel on the front plate of the Sweep Drive Gear Box and place the appropriate chain over the chain wheels. Then tighten the chain with the idling wheel.

8) Screw the type UT0014 chain wheel with coupling into engagement with the drive shaft II of a type 2305 Level Recorder (Brüel & Kjær), or mount the 80 teeth chain-wheel with a slotted shaft through the hole on the right-hand side of the RADIOMETER type NS3 Recorder.

9) Position the recorder so that the long chain that is placed over the chain wheel of the recorder and the chain wheel of the gear box can be tightened correctly by the idling wheel.

In order to make it possible to repeat a recording on the same curve sheet with a minor displacement relative to the first recording, it is important not to tighten the chains too much. The chain links must pull at the roots of the teeth.

10) Choose an adequate speed of rotation of the drive shaft. The max. speed of the 120 rpm of the type 2305 Level Recorder varies the tuning frequency of the analyzer with 1 kc per second.

The BANDWIDTH setting, that gives maximum selectivity without having any disturbing influence on the amplitude recording, depends on how steep the steepest section of the recorded curve is, and on how great the rotational speed of the tuning capacitor is.

The allowable turning speed rises as the square of the factor relating the bandwidths.

A turning speed of 10 cps per second with a BANDWIDTH setting of  $\pm 3$  cps will give a correct recording of the amplitude of single components present in the input voltage of the analyzer, but 30 cps per second can be used if a somewhat lower accuracy can be tolerated.

The turning speed of 10 cps per second is on the other hand so high, that practically none of the "spurious" signals are recorded, because they are so exceedingly "narrow" and weak (-85 dB).

11) If the recorder used to drive the analyzer through the gear box has the driving wheel on its left-hand side, move the drive shaft of the type SDG1 gear box and also the idling chain-tension wheel to the right-hand side. This can be done without taking the box apart.

If the direction of rotation is wrong, take the box apart and mount the pinion-wheel on the other side of the large gear wheel.

#### 10. Low-Level Microphone Measurements

1) Connect two Wave Analyzers, type FRA3, for slave analyzer operation (See section 8).

2) Adjust the BFO section of the master analyzer (see section 4)...

3) Connect a power amplifier to the BFO output of the master analyzer and a loudspeaker to the power amplifier.

4) Connect a (regulating) microphone with straight response (condenser microphone) to the input of the slave analyzer via a microphone amplifier. Set the BANDWIDTH of the slave analyzer to  $\pm 100$  cps in order to avoid oscillations in the regulating channel.

5) Place the microphone in front of the loudspeaker at a proper distance, either in a free field or in an anechoic chamber.

6) Adjust the BFO OUTPUT from the master analyzer, and the amplification

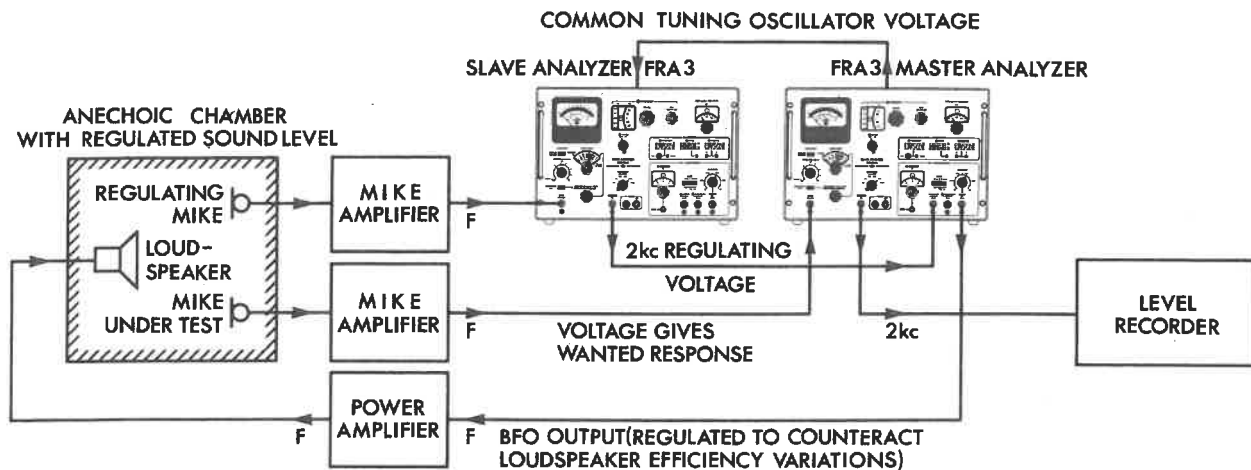

Fig.14. Measuring set-up for low-level microphone measurements.

of the power amplifier, so that the sound level at the (regulating) microphone has the correct value at that frequency where the efficiency of the loudspeaker, and consequently the sound level, is at its minimum (within the range in question). This minimum must not lie more than approx. 30 dB below the maximum output from the loudspeaker in order not to violate the regulation.

Make sure that the power amplifier and the microphone amplifier are not overloaded at any frequency within the range. Otherwise there is a risk that oscillations will build up when the regulation loop is established.

The sound level is easily found (if the sensitivity of the microphone and the amplification of the microphone amplifier are known), when the output voltage of the microphone is read on the meter of the slave analyzer.

7) Adjust the sensitivity of the slave analyzer (by means of the INCREMENTAL GAIN knob) so that approx. full deflection is had.

8) Connect the RECORDER output terminal of the slave analyzer to the AGC INPUT terminal of the master analyzer and make sure that a small drop occurs

(approx. 0.5 dB) after some seconds in the meter deflection at the slave analyzer. If not, repeat (7) and (8).

The regulation has now just started and has lowered the previously set sound level by approx. 0.5 dB.

9) Raise the output from the BFO section of the master oscillator or the amplification of the power amplifier by 6 to 10 dB in order to place the working point on the steeper part of the regulation curve, thus providing efficient regulation.

The regulating range of approx. 60 dB is then lowered accordingly, but it will in general be sufficient, because applicable loudspeakers do not have a response that varies as much as 30 dB in their operating frequency range.

10) Readjust the INCREMENTAL GAIN sensitivity of the slave analyzer in order to obtain the exact sound pressure. Vary the frequency through the range in question and watch the sound pressure variations on the meter of the slave analyzer. Bear in mind that the deflection of the slave analyzer meter is almost independent of the three knobs determining the sensitivity (MAX. INPUT VOLTAGE, METER RANGE and INCREMENTAL GAIN) as long as the regulating range is not violated, but that the sound pressure changes according to the settings with only 0.15

dB deficit for each 10 dB change, as does the meter reading of the output meter of the microphone-amplifier (if any).

11) Place the microphone (hearing aid) under test next to the regulating microphone. Feed the output of the microphone amplifier (or the hearing aid) to the INPUT terminal of the master analyzer.

12) Connect the RADIOMETER type NS3 Recorder or the Brüel & Kjær type 2305 Level Recorder to the master analyzer by means of a RADIOMETER Sweep Drive Gear Box, type SDG1, and connect the RECORDER output terminal of the master analyzer to the input of the recorder. (See section 9).

13) Choose a recorder speed in accordance with the BANDWIDTH setting of the master analyzer and the steep portions of the loudspeaker response curve.

If the recording speed is correct, a lower speed will give only minor deviations from the curve recorded at the higher speed.

14) Attenuate the (ordinarily high) low-frequency noise signals at the input of the slave analyzer by means of an appropriate high-pass filter if the noise disturbs the measurements at the low signal level wanted. (Use the "sound level meter curves" A or B of the microphone amplifier of the regulating microphone if the amplifier has this feature.)

The measuring range is restricted to the pass range of the filter. Measurements down to 30 or even 20 dB above threshold of hearing are then possible in a room (laboratory with a dozen individuals) with a sound pressure (curve C) of about 50 dB.

## Section F. Circuit Description

### INPUT ATTENUATOR

The input attenuator has eight positions and gives max. 70 dB attenuation in steps of 10 dB.

The attenuator consists of four sections with respectively 10, 20, 30, and 60 dB attenuation. Two sections are connected in cascade when 40, 50, or 70 dB attenuation is needed.

Part of the revolving dial of the attenuator is visible in the window of the METER RANGE switch. The extreme right-hand reading gives the max. permissible input voltage if the residual distortion of the analyzer must not lie higher than the guarantee value. Otherwise a 10 dB rise in input is within the linear range and thus gives a 10 dB rise in residual distortion. The input impedance is constantly 1 M $\Omega$  in parallel with 45 pF on all ranges, and the accuracy of attenuation is within 1 % on all ranges up to 100 kc.

On account of the constant input impedance, connection of a 9 M $\Omega$  probe (which can be capacitively balanced to the input capacity) can raise the input impedance to 10 M $\Omega$  (at low frequencies).

### INPUT AMPLIFIER

The input amplifier can be divided into three sections.

Section 1 consists of the input tube V100 and its associated emitter-follower Q100.

The NUVISTOR tube is operated as a cathode-follower and provides for high input impedance (1 M $\Omega$ ) and low noise, which do not rise appreciably at low frequencies. The tube filament is used as a decoupling resistor for the power supply of the BFO tone generator's output stage. The maximum output current of the power supply is restricted so that the filament is safeguarded.

The second harmonic generated by the tube is slightly compensated by a partial decoupling of the resistor (R103) in the emitter of the following emitter-follower, so that the second (and strongest) harmonic of the emitter-follower output is lower than -100 dB, even at maximum output.

Section 2 is a two-stage amplifier (Q101-Q102) with heavy negative feedback. The adjustable emitter-resistor of the first transistor (R105) sets the current and voltage of the second transistor so that the impedance of the signal source (feeding the second transistor), which gives minimum of second harmonic, is precisely the collector impedance of the first transistor.

The second harmonic is easily set to less than -100 dB at maximum input voltage (100 mV). The amplification can be varied continuously by means of the INCREMENTAL GAIN potentiometer (R10) over a 10 dB range without violating the -100 dB second harmonic level. An adjustable resistor (R121) in parallel with the INCREMENTAL GAIN potentiometer enables an adjustment of the range to exactly 10 dB.

The amplification is set to minimum (NORMAL) automatically (and is thus independent of the INCREMENTAL GAIN setting) when the sensitivity is calibrated (METER RANGE set to extreme right-hand position).

The third section is a double emitter-follower (Q103-Q104) that supplies a current of approx. 0.3 mA to the first mixer with a resulting second harmonic (and higher harmonics) lower than -100 dB.

All components of the input amplifier are numbered between 100 and 200, and they are mounted on a detachable printed board that is placed vertically in the lower left-hand corner of the analyzer.

#### 60 kc INPUT LOW-PASS FILTER

The filter attenuates any signal outside the measuring range sufficiently to ensure that spurious signals are typically 85 dB down. The coil L2 is so adjusted that a maximum of attenuation is obtained at 120 kc in order to prevent any signal of that frequency from reaching the 120 kc I.F. band-pass filter with a disturbing level. Otherwise a deflection would occur independently of the tuning.

The filter is terminated with approx. 1 k $\Omega$  at the input and the output. In series with the output termination (R219-R17-RT1) lies the transformer T1 of the first mixer. The temperature-dependent resistor RT1 largely compensates the drift with temperature of analyzer sensitivity. Because this drift is mainly due to variations of the temperature-dependent loss

in the filter coils L5 to L9 of the 120 kc I.F. band-pass filter, RT1 is placed inside the air-cored transformer T1, which is made of the same parts as the coils and mounted together with them.

#### FIRST MIXER

The first mixer converts any input signal frequency between 0 and 60 kc to a 120 kc signal (amongst many others) with amplitude proportional to the input signal. The mixing action is accomplished by the two inverted transistors Q200 and Q201, which in turn connect the ends of the primary winding of transformer T1 to ground when the transistors are bottomed by a strong current (approx. 4 mA) being fed into their base from the flip-flop transistors Q202 and Q203. When one mixer-transistor is turned on, the other is switched off by a positive voltage fed to the base. The signal current fed to the center tap of the transformer T1 thus flows either to one end of the primary winding or to the other end at a rate determined by the flip-flop. The lower side-frequency of the flip-flop frequency present at the secondary of the transformer T1 is set at exactly 120 kc by tuning the oscillator that drives the flip-flop.

If the oscillator frequency deviates only slightly from 240 kc, the flip-flop frequency will be close to 120 kc, and disturbance will occur at low input frequencies if this voltage is present at the secondary of the transformer T1. But when the two BALANCE settings R and C have been properly set, measurements at 10 cps are possible down to a level lower than 100  $\mu$ V.

The two mixer-transistors must yield a resistance, when they are in the leading state, that is independent of the signal current through them, otherwise harmonics of the signal frequency are produced. In order to keep this mixer distortion at a -100 dB level - typically - throughout the entire frequency range, the transistors are selected spec-

imens. About 20% of a batch is usable for this purpose.

All components of the first mixer are numbered between 200 and 300, and they are mounted on a detachable printed board located just above the meter.

#### FLIP-FLOP

The transistors Q202 and Q203, together with the two diodes CR200 and CR201, constitute the active components in the flip-flop, which switches the two mixer transistors Q200 and Q201 from a conducting state into a non-conducting state in a very short time. In order to ensure a sufficiently low mixer distortion, the voltage at test points 200 and 204 should increase by about 50 volts per microsecond when passing through zero.

The flip-flop is triggered by a square-wave signal from a shaper-stage (Q204 and Q205), which gets its input either from an external oscillator or from the F-FREQUENCY oscillator. The switch S5 on the rear plate with the positions EXT - INT switches between the two modes of operation.

The flip-flop voltage is also supplied to the beat-frequency oscillator section via the transformer T200 which gives a step-down of two.

In addition, a small fraction of the flip-flop voltage goes to the METER RANGE switch and, when this switch is set to its frequency calibration position, also to the second mixer. This mixer allows only a 120 kc signal to pass, and the F-dial reading can thus be calibrated when the dial is set to zero (where the flip-flop frequency must be 120 kc), and the COARSE and FINE settings are so adjusted that maximum meter deflection is obtained.

All components of the flip-flop are mounted together with the components of the first mixer on a printed board placed just above the meter. The components are numbered between 200 and 300.

#### F-OSCILLATOR

The F-OSCILLATOR tunes the analyzer to the input frequency  $F$  when operating at the frequency  $240 \text{ kc} + 2 F$ .

The oscillator has two frequency ranges which are selected by means of the switch F-RANGE  $\times 0.1 - \times 1$ .

With the F-RANGE switch set to  $\times 1$ , the oscillator frequency lies in the range from 240 to 360 kc (366 kc), providing for a measuring range from 0 (10 cps) to 60 kc (63 kc). With the switch set to  $\times 0.1$  the measuring range is 0 (10 cps) to 6 kc, and the oscillator range 240 kc to 252 kc.

The frequency scale is common to both ranges and strictly linear.

The tuning within the two frequency ranges is made with a two-gang high-precision variable capacitor of an exceptionally sturdy design and with a worm-drive scale having a total length of 6.9 metres.

The high-quality ball-bearings and worm-drive ensure low friction, high resetability and negligible backlash provided that the instrument rests on its feet. The unavoidable variations in gearing, owing to deviations from the theoretical shape of the worm-drive, are compensated for by a variable correction capacitor mounted on the spindle of the worm-drive, and an unsurpassed accuracy of frequency is thus obtained.

The oscillator transistor Q401 is very loosely coupled to the circuit, and aging and heating of the transistor are therefore without noticeable influence on the oscillator frequency.

Both frequency ranges are carefully temperature-compensated, thereby ensuring high accuracy in frequency reading and limiting the need for temporary recalibration when measuring at low frequencies.

The F-OSCILLATOR output is taken from the transistor Q400 which operates as an emitter-follower. It delivers approx. 2 V to the jack: F-FREQUENCY  $240 \text{ kc} + 2$

F- OUTPUT on the rear plate and, via a switch (enabling the use of an external oscillator), also to the shaper stages that trigger the flip-flop in which the frequency is divided by two.

The CAL.F-FREQ. FINE (and COARSE) adjusting capacitors on the front plate must be reset when switching from one frequency range to the other in order to obtain maximum accuracy of frequency. When the adjustment has been properly made, the frequency of the F-OSCILLATOR will be set so that the halved frequency (from the flip-flop) is exactly 2 kc higher than the frequency of the second oscillator operating at 118 kc. The second mixer will then produce a 2 kc signal which can travel further. The F-OSCILLATOR, consisting of the main tuning capacitor and associated components, forms a unit that is connected to the analyzer by an approx. 1 m long cable (W18). It is mounted on the front plate and insulated from this in order to avoid hum pick-up and "spurious" signals. The unit can be dismantled without affecting the normal use of the analyzer, thanks to the long connecting cable, which may prove valuable when servicing the instrument.

All oscillator components are numbered between 400 and 500, and they are mounted on a printed board, which is connected to the tuning capacitor through a print-connector or placed on a mounting plate on the capacitor.

#### 120 kc IF BAND-PASS FILTER

The lower side-frequency of the flip-flop frequency, produced by mixing with the input frequency, is always placed at 120 kc (with the second oscillator operating at 118 kc) when the analyzer is properly tuned. This side-frequency is filtered out by the 120 kc intermediate frequency band-pass filter. The filter consists of two critically coupled band-pass filters with coils L4, L5, and L8, L9. The two band-pass filters are connected by a circuit (with coils L6 and L7) that has series resonance at 120 kc and parallel resonance at 116

kc, so that the "image" frequency of the second mixer is attenuated by approximately 100 dB. The bandwidth between the -1 dB points on the selectivity curve of the filter is approx. 1 kc, and the -0.2 dB bandwidth is approx. 200 cps. The maximum  $\pm 100$  cps change in the 120 kc intermediate frequency occasioned by changing the frequency of the second (118 kc  $\pm 100$  cps) oscillator by maximum 100 cps (when using the INCREMENTAL FREQUENCY dial) thus results in only small change in sensitivity.

The band-pass filter is constructed with low-loss, high-stability components, and the necessary adjustment is made with air gap trimmer capacitors. The low-loss filter provides for a maximum input voltage to the second mixer, and the contribution to the noise level from the second mixer is thus kept at a level that approximately equals the thermal noise level at the  $1M\Omega$  input impedance. An optimum between residual distortion and noise is therefore obtained with an audio frequency input to the first mixer, which is low enough to ensure the low residual distortion.

The loss of the 120 kc filter is dependent on temperature. In order to compensate for the influence on the sensitivity, the input current to the first mixer is made to increase appropriately with rising temperature by means of the temperature-dependent resistor RT1 mounted inside the transformer T1. By this means, a nearly constant sensitivity is ensured, also during the warm-up period.

All filter-components are mounted on three vertical plates located in the left-hand rear upper corner of the instrument.

#### EMITTER-FOLLOWER

The emitter-follower connected to the last circuit of the 120 kc band-pass filter has an input impedance of  $0.1 M\Omega$  that terminates the filter correctly. The next stage is also an emitter-follower capable of supplying the current for the following 30 dB attenuator of the METER RANGE attenuator with the low distortion needed.



All components (numbered 500 to 600) are mounted on the vertical printed board which has two connectors.

## SECOND MIXER

The second mixer produces a 2 kc intermediate frequency signal by mixing the 120 kc signal from the double emitter-follower with a 118 kc signal from a second oscillator.

The 120 kc signal is fed to the base of transistor Q502, whose amplification is switched between two distinct values by connecting and disconnecting a resistor (R534) in parallel with the emitter resistor (R516). The switching is accomplished by means of the transistor Q506 placed in series with R534. The transistor is switched from a conducting to a non-conducting state by means of a 118 kc square-wave signal with a very fast rising and falling voltage of approx. 100 V per microsecond in order to obtain the low distortion necessary to reduce the sensitivity (to a level of minus 100 dB) at a tuning frequency that is 1 kc (0.5 x second I.F.) lower than the input signal frequency.

The "spurious" signals from the second mixer are due to harmonics of a very high order (30 to 100) of the oscillator signal. They are so weak and "narrow" that they are difficult to find. Any signal down to a minus 90 dB level can be measured by proper tuning that places the "spurious" outside the pass-band without having any influence on the deflection that the signal produces.

## SECOND OSCILLATOR (118 kc $\pm$ 100 cps)

The second oscillator operates at 118 kc when the INCREMENTAL FREQUENCY dial is set to zero. The frequency can be altered by maximum  $\pm$ 100 cps with this dial.

The first intermediate frequency of 120 kc is then compelled also to alter by the same amount, because the frequency difference always must be 2 kc. The second mixer produces this difference frequency,

and only if it is exactly 2 kc, can the signal travel further.

The tuning of the analyzer can thus be made either with the F-FREQUENCY dial or with the INCREMENTAL FREQUENCY dial. The latter has a resolution that is five times as high as that of the F dial when operating on the 0 to 60 kc range.

If two analyzers are tuned by a common F-OSCILLATOR, the two second oscillators (118 kc) can be set to the same frequency by using the INCREMENTAL FREQUENCY dial of one of the analyzers, and it is thus possible to tune two (or more) analyzers to exactly the same input frequency throughout the entire range (slave analyzer operation).

The transistor Q716 of the oscillator is very loosely coupled to the circuit which is made of high-stability components. The frequency drift with temperature is therefore very low (of the order of  $10^{-5}$  per degree centigrade) and this, together with a low drift of the F-oscillator frequency, ensures a high calibration accuracy. The oscillator output (approx. 1 V rms) is available at the 118 kc jack on the rear plate.

The output impedance is 10 pF. Any load can be connected when the ensuing slight detuning of the oscillator is corrected, either by means of the INCREMENTAL FREQUENCY dial or by recalibrating the frequency dial as stated on the front plate.

The oscillator components are marked 700 to 800, and they are placed on the large printed board at the right-hand side of the analyzer. The components are located close by the INCREMENTAL FREQUENCY capacitor:

## SHAPER

The 118 kc  $\pm$ 100 cps output from the second oscillator is clipped in three stages, Q503, Q504, and Q505, before it is fed to the chopper transistor of the second mixer.

The voltage rises here with approx. 100 V per microsecond and ensures a very low distortion of the second mixer. (See Second Mixer).

The shaper components are marked between 500 and 600, and they are mounted on the large vertical printed board in the hinged frame on the rear of the chassis.

## 2 kc BAND-PASS FILTER

The two 2 kc band-pass filters are identical. The band filters have variable coupling, which can be switched by the BANDWIDTH switch with the six positions  $\pm 3$ ,  $\pm 6$ ,  $\pm 12$ ,  $\pm 25$ ,  $\pm 50$  and  $\pm 100$  cps. The two circuits of a band filter are critically coupled for all settings of the BANDWIDTH switch, because the circuits are damped with resistors that are switched in when the coupling is made tighter to obtain a greater bandwidth. The correct Q value of the coils is obtained by the screwdriver-operated, internal variable resistors ADJ. CIRCUIT DAMPING. In order to obtain a circuit impedance, and thereby an amplification, that is independent of temperature, the Q value of the four coils is made practically independent of temperature, and to avoid a decrease in amplification due to different detuning of the four 2 kc circuits, the circuits are so chosen from the batch that their resonant frequency is similarly dependent on the temperature. The unavoidable slight drift away from the nominal frequency is only approx. one single cps during the warm up, which raises the temperature of the coils and tuning capacitors approx. 2 degrees centigrade. The drift with temperature has thus very little influence on sensitivity and on frequency dial reading.

The coils are ferrite pot-cored. The pot cores are cemented together (Araldite) in order to obtain highest stability. A copper ring shields the coils against 2 kc pick-up from the transformer of the power supply. The tuning capacitors are hermetically sealed, low-loss, high-stability types. The trimming of the circuits is accomplished by means of trimmer capacitors instead of

core trimming-slugs in order to obtain maximum stability. The restricted range of the trimmer capacitors is handled by arranging three coarse trimmer capacitors on the coil-bearing component-board in such a way that easy connection and disconnection is possible (C44-45-46 and equivalents). Both band-pass filters receive their input current from a source with about 180 k $\Omega$  impedance. The current is fed to a coil-tap that is switched when the bandwidth is switched in order to obtain constant input impedance (11 k $\Omega$ ). The available current from the second mixer restricts the maximum obtainable bandwidth to  $\pm 100$  cps.

The selectivity curves are all flat-topped and steadily falling beyond -100 dB. By avoiding over-critically coupled band-pass filters, their very pronounced tendency to develop unequal "shoulders" (even with high-stability components or crystals) is avoided. Another advantage is the very simple trimming.

The coils of the band-pass filter are numbered L10, L11, L12, and L13, and also the capacitors and resistors have numbers lower than 100.

The coils are mounted beneath the lower shelf and are covered by a shield. The capacitors are mounted just above the lower shelf and are also shielded. Both shields are necessary to make the additional error in sensitivity, that is introduced when the METER RANGE switch is set to its most sensitive position, as small as possible (approx. 1%).

## 2 kc BUFFER AMPLIFIER

Between the two 2 kc band-pass filters is placed a buffer amplifier. This amplifier has two stages that operate with heavy feedback which rises with rising frequency in order to avoid overdrive of the amplifier by a 120 kc + A input voltage that is of the same magnitude as the 2 kc signal.

The 2 kc signal is amplified about 80 times. The 2 kc input impedance is adjusted to about 180 k $\Omega$  by means of the input shunting resistor R600, so that the 11 k $\Omega$  out-

put taps of the band-pass filter are correctly loaded. The amplifier feeds a 2 kc current through a resistor of approx. 180 k $\Omega$  to the 11 k $\Omega$  input taps of the next 2 kc band-pass filter, and thus loads the band-filter correctly. The current-feeding resistor consists of two resistors. The smaller resistor is switched, when the bandwidth is switched, and is adjustable except on the  $\pm 100$  cps bandwidth range. The sensitivity can thus be set to the value present in the  $\pm 100$  cps bandwidth range by setting the five ADJ. SENSITIVITY variable resistors. A capacitor (C607) connected to the junction between the two resistors, feeding current to the 2nd band-pass filter, provides for heavy attenuation of the 120 kc + A signal from the buffer amplifier.

The components of the buffer amplifier are numbered between 600 and 700, and they are mounted on a printed board located beneath the lower shelf.

#### 2 kc AMPLIFIER No.1

The 2 kc amplifier No.1 is also a two-stage amplifier and almost equivalent to the 2 kc buffer amplifier. The feedback is 6 dB stronger and the amplification is therefore halved.

The amplifier gets its input from the second 2 kc band-pass filter, and the resistor R535 provides for correct loading on the band-pass filter.

The output impedance of the amplifier is low (approx. 50 $\Omega$ ), due to the heavy feedback.

The components are numbered between 500 and 600, and they are soldered on the large printed board on the hinged frame at the rear of the chassis.

#### METER RANGE ATTENUATOR

The meter range attenuator consists of two sections.

The first section is placed at the input of the second mixer and attenuates the 120 kc signal from the first mixer by 0 or 30 dB.

With the meter range switch in the last four (most sensitive) settings at the extreme left, the signal to the second mixer is not attenuated.

The second section is placed after the 2 kc amplifier No.1. It attenuates the 2 kc signal by 0 - 10 - 20 or 30 dB.

The total attenuation range is thus 60 dB in steps of 10 dB.

The input impedance of the attenuator is 4.7 k $\Omega$  at the first section and 14.6 k $\Omega$  at the second section, while the output impedance is max. 150  $\Omega$  at the first section and constantly 3.3 k $\Omega$  at the second section.

Both sections are only slightly loaded at their output at 2 kc, but the second section has a capacitor (C524) as an output load which provides for an attenuation of the remaining oscillator signal to a level that does not give rise to perceptible meter deflection, even if no input signal is present.

The resistors of the attenuator are high-stability (0.5%) metal film resistors, and they are mounted directly on the attenuator switch.

The two extreme right-hand settings of the METER RANGE attenuator are used only when calibrating the frequency dial or the sensitivity.

In the extreme right-hand setting, a 1 kc square-wave signal of high voltage-stability is fed to the input from an internal oscillator, making possible a quick calibration of the sensitivity.

In the next position, a signal is fed directly from the flip-flop oscillator to the second mixer. It makes possible the dial calibration when both frequency dials (F-dial and INCREMENTAL FREQUENCY dial) are set to zero and the FREQUENCY FINE control is adjusted for maximum deflection.

## 2 kc AMPLIFIER No.2.

The 2 kc amplifier No.2 is almost equivalent to the 2 kc amplifier No.1.

The heavy feedback in the two-stage amplifier provides for high input and low output impedance. The amplification is approx. 19 times.

The input signal supplied by the METER RANGE attenuator is always the same at full deflection, independently of the setting of both attenuators (INPUT and METER RANGE).

The output voltage from the two-stage section is fed to a single stage (Q511) with heavy local feedback. The 2 kc signal is had with practically no attenuation at the emitter of the transistor and appears amplified at the collector. This voltage is filtered by a 2 kc circuit (L500-C532) for induced hum before being fed to the RECORDER jack on the front panel.

The output voltage is approx. 1.8 volts at full meter deflection, but approx. 6 volts are available if the analyzer input is overdriven by 10 dB, giving a rise of approx. 10 dB in residual 2nd harmonic. As the voltage at the RECORDER jack is approx. 0.3 mV with no input signal to the analyzer, a dynamic range of approx. 85 dB is obtainable, if the rise to maximum -75 dB in residual distortion in the analyzer can be allowed for.

The output impedance of the RECORDER jack is approx. 2 k $\Omega$ .

The 2 kc voltage at the emitter of Q511 is fed via a capacitor (C533) to the screwdriver-operated potentiometer for METER CALIBRATION mounted on the front panel. The capacitor slightly attenuates the 2 kc signal and greatly attenuates any disturbing hum components.

The output from the METER CAL. potentiometer goes via the BROADBAND pushbutton, if not pressed, to the meter amplifier.

## METER AMPLIFIER

The meter amplifier receives an input signal of 2 kc at normal analyzer operation, when the BROADBAND pushbutton is not pressed. If the button is pressed the output voltage from the input amplifier is fed directly to the meter amplifier with an amplitude set by the variable resistor ADJ. BROADBAND SENSITIVITY. The METER RANGE switch is therefore inoperative and only the BROADBAND METER RANGE and the INCREMENTAL GAIN settings determine the sensitivity which is read under the upper arrow in the METER RANGE window. The maximum sensitivity is thus 30 mV and the minimum sensitivity 300 V.

The response is approx. 5 % from 10 cps to 300 kc.

The amplifier has a symmetrical lay-out in order to obtain as small a leakage current as possible in the electrolytic capacitors necessary for a slow meter speed. The leakage current must be a fraction of a microamp. in order to avoid a perceptible meter deflection, if no output signal is present.

## METER RECTIFIER

The meter rectifier circuit is connected between the collectors of the two meter amplifier transistors Q512 and Q513. The rectifier yields a meter current that lies between that obtained from a peak rectifier and that obtained from a mean-value rectifier. If the input voltage is a white noise voltage, or up to five superimposed sinusoidal voltages of equal magnitude, the meter current is proportional to the rms value, even at full deflection; but if a heavily distorted signal is fed to the meter rectifier, an indication deviating somewhat from the rms value is unavoidable. If, for example, the 1 kc square-wave signal used for calibrating the sensitivity is measured by pressing the BROADBAND pushbutton, the rise in indication is not the 10 % shown by a true rms meter.

## A-OSCILLATOR

The A-oscillator signal is mixed with the flip-flop signal and in this manner the audio frequency signal (10 cps to 60 kc) is generated.

The oscillator is an equivalent of the F-oscillator and the 118 kc oscillator, and is therefore highly independent of transistor aging (Q602). The frequency varies only very little with temperature (approx.  $10^{-5}$  per degree centigrade), and because the flip-flop frequency is very stable, too, the drift of the BFO output frequency is low (of the order of a few cycles per hour after a run-in time of one hour).

The A-oscillator frequency can be varied between 118 kc and 122 kc by means of the A-FREQUENCY dial. If this dial is set to zero, and if the ZERO knob of the circuit is properly adjusted, then the oscillator frequency will be 120 kc (provided that the second oscillator is operating at 118 kc (INCREMENTAL dial at zero). The output frequency of the beat-frequency oscillator is then exactly that of the tuning frequency of the analyzer section. The output from the A-oscillator is approx. 25 mV and is taken from a single-turn winding on the oscillator coil.

The output frequency of  $120 \pm A$  kilocycles is fed to the REGULATING STAGE and via a 100  $\Omega$  resistor (R623) to the jack 120 kc -A on the rear panel. Loading this jack - even severely - gives only a minor detuning of the oscillator.

The components of the A-oscillator are numbered between 600 and 700, and they are mounted on a printed board (together with the 2 kc buffer amplifier) which is placed just beneath the lower large shelf.

## REGULATING STAGE

The regulating stage attenuates the output from the A-oscillator before it is directed onwards to the BFO mixer.

The regulating stage consists of two transistors (Q703) and (Q702) connected as a long-tailed pair, i.e. with a common high emitter-resistor.

With no input signal to the AGC INPUT jack, the oscillator signal present at the base of Q703 is found unattenuated at the emitter of Q702.

With an input signal of approximately 1.2 volts at the AGC INPUT jack, Q702 starts to lead, and the current of Q703 is reduced, as is the oscillator signal at the emitter of Q703, giving a reduction in the BFO output voltage. The reduction can grow to some fifty dB or even more. The output of the regulating stage is amplified in transistor Q704 whose amplification can be adjusted by means of R716, ADJ. OUTPUT, giving the proper BFO output voltage of max. 4 volts.

## AGC AMPLIFIER

The automatic gain control amplifier consists of a phase-splitter stage (Q700), a full-wave rectifier (CR700 to CR703) and an emitter-follower (Q701).

An input voltage of approx. 1.2 volts (30 cps to 100 kc) to the phase-splitter develops such a (filtered) dc voltage at the emitter-follower base that the transistor Q702 of the regulating stage be-

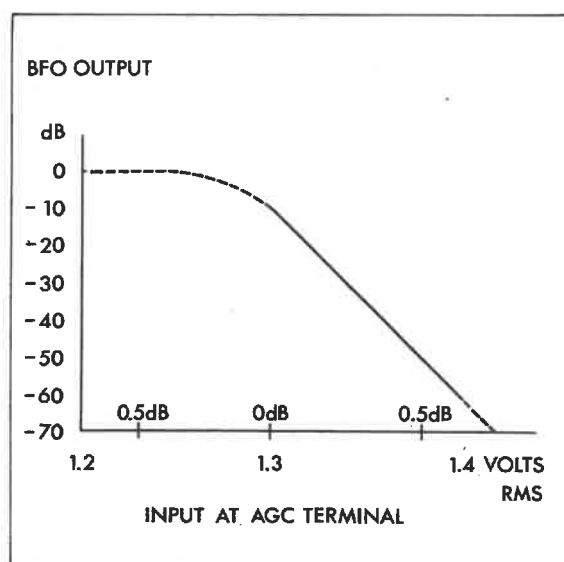

Fig. 15. AGC Regulation of the Wave Analyzer, type FRA3.

gins to conduct, and its emitter voltage becomes more negative. This partly shuts off the transistor Q703, and an attenuation of the BFO output takes place. Maximum attenuation is had with approx. 1.5 volts input (see Fig. 15).

The time constant of the regulation is approx. 0.15 seconds and depends mainly on the RC filter R707-C706 that feeds the rectified negative AGC voltage from the rectifier to the emitter-follower, Q701. Q701 lowers its emitter current when the AGC INPUT voltage rises (slightly) beyond the "starting" voltage of approx. 1.2 volts.

#### 120 kc BFO BAND-PASS FILTER

The A-oscillator signal reaches the 120 kc BFO band-pass filter via the regulating stage and its amplifier Q704.

The filter severely attenuates all harmonics generated in the regulating stage in order to ensure as low BFO distortion as possible.

The distortion, including the mixer distortion, is approx. -90 dB (and equal to the BFO output distortion at reduced output) when no regulation takes place. The distortion rises when regulation is made by means of the BFO output frequency proper. This rise in distortion is most pronounced at low frequencies, because the unavoidable ripple after the dc filter R707-C706 of the regulating voltage rises with falling frequency. The ripple voltage can be lowered by raising the time constant of the RC filter, but this gives slower regulation.

The ripple voltage modulates the amplitude of the A-oscillator frequency present at the output of the regulating stage. The oscillator frequency and the side-frequencies generated by the amplitude modulation travel unattenuated through the band-pass filter which has a pass-band from 110 kc to 130 kc.

The distortion is nevertheless kept at such a low level even at 30 cps (approx. -25

dB) that the rms value of the total signal and rms value of the fundamental (to which the analyzer always is tuned, when "internal" regulation is used) have no significant difference.

#### BFO BUFFER FOR MIXER

The BFO buffer amplifier is a single emitter-follower (Q705) which receives its signal from the 120 kc band-pass filter. The input impedance of the emitter-follower is established at 1 k $\Omega$  in order to terminate the band-pass filter properly.

The emitter-follower provides for the resistive input impedance necessary for the following mixer.

#### BFO MIXER

The mixing stage of the BFO consists of the two transistors Q706 and Q708. The Q706 is operated as a chopper-amplifier, whose amplification is chopped between two levels determined by the two resistors R728 and R726. The amplification is high when the two resistors are paralleled by throwing Q708 in its leading state; otherwise the amplification is lower. The chopping frequency is that of the flip-flop of the first mixer in the analyzer section.

The output from the flip-flop is taken via the transformer T200, which has a step-down of 2:1 and gives a separation between grounding points that enables a lowering of the interaction (cross-talk) between the BFO and the analyzer input to a level of some microvolts at frequencies higher than 200 cps. At lower frequencies the cross-talk rises. (3  $\mu$ V to 30  $\mu$ V at 20 cps. See also section BFO OUTPUT EMITTER-FOLLOWER.) The flip-flop signal is shaped in the transistor Q707 so that a square-wave signal with very steep sides (300 V per microsecond) is obtained. By this means, the unusually low distortion level of -90 to -100 dB is achieved without getting a disturbing high noise level. The noise

level is below -100 dB of full output in the major part of the frequency range, even at 100 cps bandwidth, and at  $\pm 3$  cps bandwidth a rise in noise is not noticed before the output frequency is lowered to 1 kc or less.

The unavoidable induced hum is reduced to a level of at least minus 70 dB (typically -80 dB) by a one-turn hum-bucking coil in series with the emitter resistor (R726) of the chopper-amplifier.

#### 60 kc BFO LOW-PASS FILTER

The low-pass filter following the BFO mixer stage strongly attenuates all mixer products except the one wanted (0 to 60 kc).

The filter is shielded by a permalloy box in order to prevent hum pick-up, and the coil L15 is adjusted for maximum attenuation at 120 kc in order to reduce the cross-talk between BFO and analyzer to a one microvolt level approximately.

#### AMPLITUDE POTENTIOMETER

The AMPLITUDE potentiometer of the BFO is of the tandem-type and wire-wound for maximum reading accuracy.

The dial reading gives the multiplication factor of the maximum output voltage, which depends on the setting on the MODE pushbuttons.

One of the potentiometers receives the signal from the 60 kc BFO low-pass filter, and terminates the filter properly.

The other potentiometer receives the signal either from the front plate jack B-FREQUENCY (button |F + A| & B pressed) or from the BFO amplifier feeding one of the output stages (button |F + A| pressed).

When using the AMPLITUDE potentiometer, the relation between the BFO signal and the B-FREQUENCY signal is kept constant within a few percents, if the output impedance of the external B-FREQUENCY generator is 10 k $\Omega$ .

#### BFO AUDIO FREQUENCY BUFFER

The output voltage from the AMPLITUDE

potentiometer terminating the low-pass filter is fed to an emitter-follower that ensures a constant and low source impedance for the following voltage amplifier.

#### BFO VOLTAGE AMPLIFIER

The voltage amplifier has two stages (Q710 and Q711) with heavy dc and ac feedback, ensuring high stability and low distortion.

The amplification depends on which of the MODE pushbuttons is pressed. The amplification is 40 times (32 dB) when the button |F + A| is pressed, and ten times (20 dB) when the button |F + A| & B is pressed.

The output voltages from the amplifier proper are max. 4 volts and 1 volt respectively with a distortion of approx. -75 dB at 4 volts output. Maximum amplification is obtained by short-circuiting a part (R749) of the feedback resistor.

#### BFO OUTPUT EMITTER-FOLLOWER

The beat-frequency oscillator has two double emitter-follower output stages, which are connected in parallel when the |F + A| MODE pushbutton is pressed.

When the |F + A| & B pushbutton is pressed, the two double emitter-followers are separated at their input terminals.

One of them remains connected to the BFO voltage amplifier, but the other is then connected to the second part of the AMPLITUDE tandem-potentiometer (R55B), at the top of which the input voltage at the B-FREQUENCY INPUT jack is present. The output voltages from the two power emitter-followers (Q713, Q714) are both fed to the same jack, OUTPUT, through two separate 1200  $\Omega$  resistors. If both transistors Q713 and Q714 get the same input with pushbutton |F + A| pressed, a maximum of 4 volts is obtainable. However, if button |F + A| & B is pressed, the |F + A| open-circuit voltage is lowered to 0.5 volts, because the |F + A| input sig-

nal is attenuated to approx. 1 volt (see BFO VOLTAGE AMPLIFIER), and because the two 1.2 k $\Omega$  resistors from the OUTPUT jack to the two emitter-followers now are connected in series and attenuate the  $|F+A|$  signal by 6 dB.

A signal from the B-FREQUENCY jack is also attenuated 6 dB, and if 4 volts are present, an open-circuit voltage of 2 volts is obtainable at the OUTPUT jack. The relation between the  $|F+A|$  signal from the BFO and the B signal is then 1:4 as recommended for measurement of intermodulation according to the SMPTE (Society of Motion Pictures and Television Engineers) method.

The tandem AMPLITUDE potentiometer provides for the correct 1:4 relation through the whole range, provided that the output impedance of the B-FREQUENCY generator is 10 k $\Omega$ .

The intermodulation between the  $|F+A|$  and B signals in the emitter-followers (if both signals are present at the same time and thus are superimposed) is lower than -100 dB (SMPTE) when the OUTPUT jack is not loaded. When loaded, the intermodulation drops further.

The dc currents through the output emitter-follower transistors are simultaneously adjusted (by R761), so that the correct collector emitter voltage is obtained, and excessive transistor heating or distortion is avoided.

The output stage is decoupled from the power supply by a two-stage RC filter. The filament of the input tube (V100) is used as a dropping resistor. The audio frequency voltage present across the filament at low frequencies and full BFO output gives rise to a small amount of cross-talk from the BFO section to the analyzer section (typically 20  $\mu$ V at 20 cps depending on tube specimen). It is therefore necessary to set the AMPLITUDE potentiometer to zero (or A-dial off zero) when making as fine a

BALANCE as possible in order to measure very low voltages at low frequencies as generated by an external tone generator.

All components of the beat-frequency oscillator (except those of the 240-360 kc oscillator and the flip-flop) are numbered between 700 and 800, and they are mounted on the vertical printed board at the right-hand side of the chassis.

#### 1 kc SQUARE-WAVE CALIBRATOR

The sensitivity of the analyzer is set to the correct value by feeding a 1 kc square-wave to the input with a fundamental of 77.5 mV.

The signal is generated in a simple free-running multivibrator, and the frequency is therefore not well-defined, but the amplitude is kept very constant by means of the Zener-diode CR804, which is of a type having a low temperature coefficient.

The calibration is not dependent on the setting of the input attenuator or the setting of the INCREMENTAL GAIN potentiometer.

The square-wave calibrator starts when the METER RANGE switch is set to its extreme right-hand position

#### POWER SUPPLY

The power supply is of the regulated type and has two balanced amplifier-stages (Q802-Q803 and Q800-Q801) in cascade for amplification of the "error signal" present between the bases of Q802 and Q803.

The amplified error signal is fed to the base of the series transistor Q1, whose internal resistance between collector and emitter then varies in such a way that the output voltage is kept independent



of load variations and power-line voltage variations.

The maximum current from the power supply is adjusted to 500 mA by means of R57. By this means the heater of the Nuvistor is protected against excessive heating due to the charging current to the "cross-talk-preventing" decoupling capacitors C70 and C731.

If the heater is switched on after having been switched off for less than three seconds, the worst condition occurs, and the heater voltage will during one second be somewhat higher than 6.3 volts, but after only ten seconds switch-off time, the heater is cooled sufficiently and will not receive more than 6.3 volts when switched on again.

## DIAGRAM CORRECTIONS

Serial numbers from 109120 to 113585

deviate from the diagrams

1591-A2-6    1592-A2-6    1593-A2-7    1594-A2-3  
1595-A2-7    1596-A2-6    1597-A2-5    1598-A2-5,

currently supplied with the manuals. The last figure in the diagram-numbers denotes the edition number, which is the highest figure found in the extreme left-hand column of the table at the foot of the relevant drawing, above the letters "Rt Nr."

The list is a good help, even if the correct issue is not present.

All diagram-codes for the components refer to their location on print-boards and chassis.

Unit	Unit code	Diagram code	Diagram
Chassis		1-99	all
INPUT AMPLIFIER	900-190	100-199	I
1. MIXER	900-191	200-299	II
TUNING CAPACITOR	280-018	300-399	II
F-OSCILLATOR	900-192	400-499	II
2. MIXER and 1. I.F. AMPLIFIER	900-193	500-599	III & V
A-OSC. and 2 kc BUFFER AMPL.	900-194	600-699	IV & VI
118 kc-OSC., BFO MIXER and BFO AMPL.	900-195	700-799	III, VI & VII
POWER SUPPLY and CALIBRATOR	900-196	800-899	VIII & I

Chassis components x)

The switch for METER SPEED is of an older type which does not discharge the capacitors C539 when released in position FAST, so that the meter pointer, due to an occasional high charge at C539, may remain hanging a while at the upper stop until the capacitor is sufficiently discharged.

2. MIXER  
2. I.F. AMPLIFIER

- 1) Q500, DIAGRAM III pos. C,4, is type 2N2189; type 2N3906 is never used.
- 2) Q501, DIAGRAM III pos. C,5, is type 2N1309; type 2N3906 is never used.

x) for serial numbers from 109120 to 109144 only.











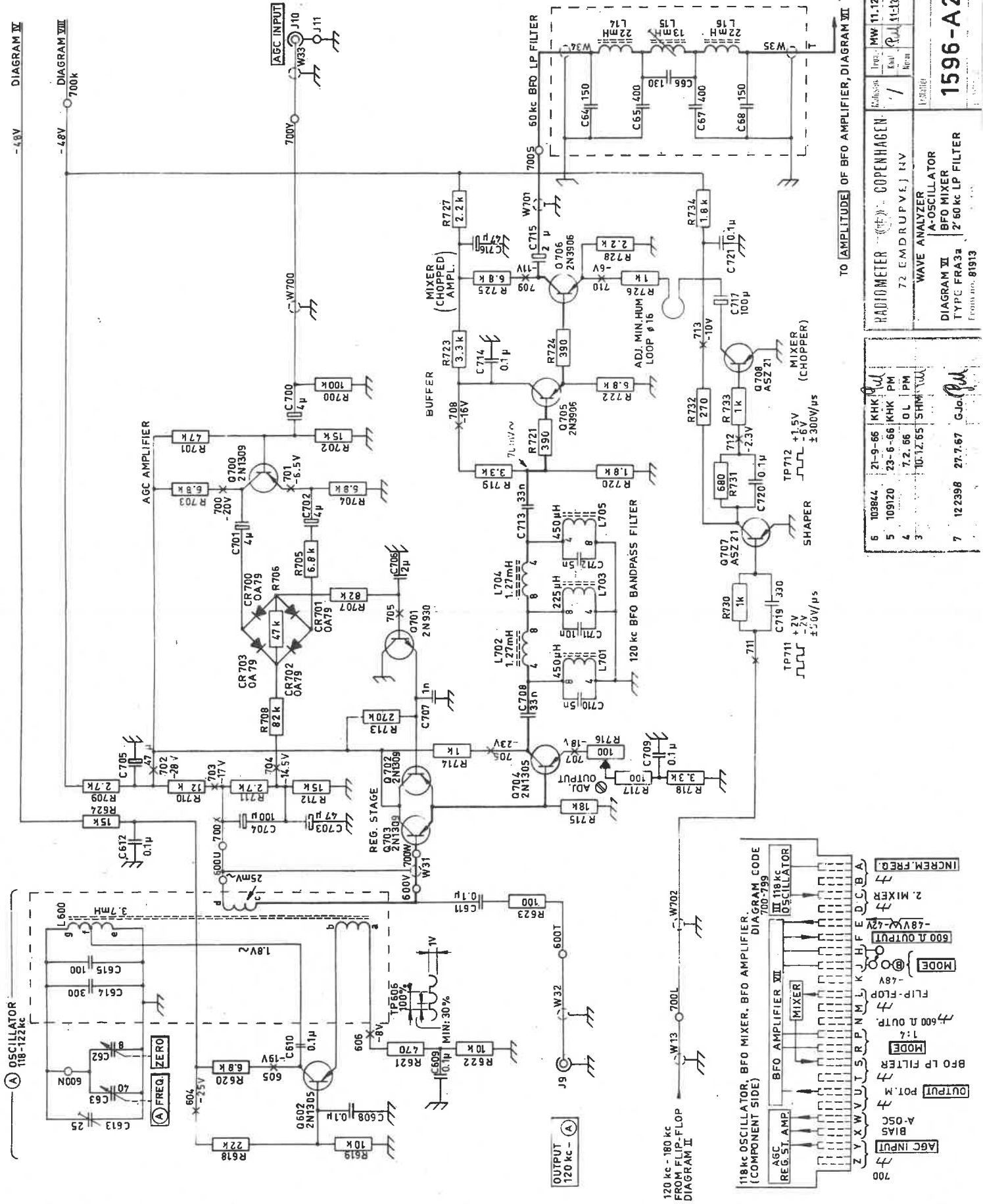

TO [AMPLITUDE] OF BFO AMPLIFIER, DIAGRAM III

RADIOMETER		COPENHAGEN	
Model	72 EMDRUPVEJ NV	Part No.	1596-A2
Year	1966	Rev.	11-12-64
WAVE ANALYZER		A-Oscillator	
BFO MIXER		2 60 kc LP Filter	
TYPE FRA3		From no. 81913	

6	103844	21-9-66	KHK	W
5	109120	23-6-66	KHK	PM
4		7-2-66	OL	PM
3		10-12-65	SHM	W
7	122398	27-7-67	GJo	PM



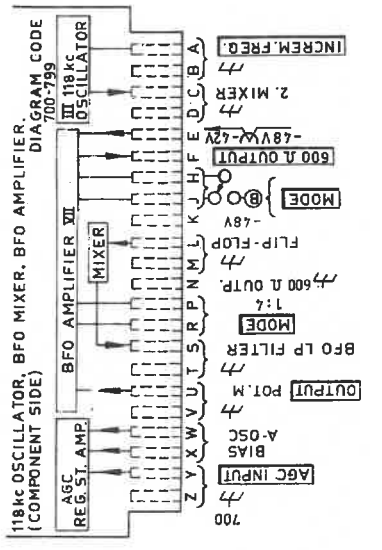

VOLTAGE AMPLIFIER  
34 dB OR 2.4 dB

OUTPUT STAGE OR SUPERPOSITION STAGES  
0 dB OR -6 dB

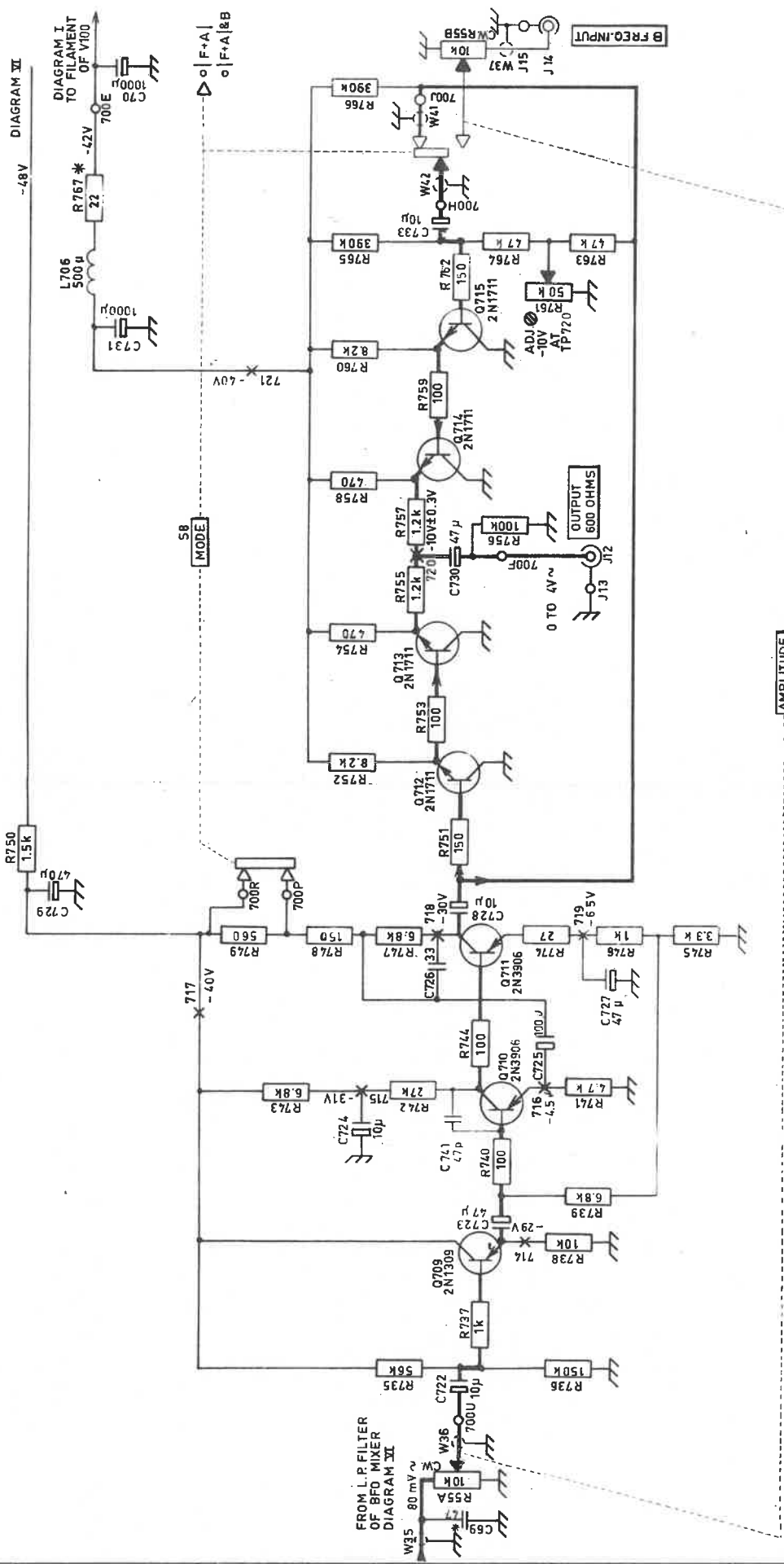

AMPLITUDE

CW = CLOCK WISE POSITION  
PRINT TERMINALS SEE DIAGRAM VI

Radiometer		COPENHAGEN	
72 EMDRUPVEJ NV		Establisher	
WAVE ANALYZER		1597-A2	
DIAGRAM VI		Type FRA 30	
From no. 8993		to no.	
Established at		11-12-64	
Malesdot		Egns. EA 11-12-64	
Konst. 11-12-64		Name	

6	18-4-67	KHK	PA
5	18-5-61	KHK	PA
4	18-9-20	KHK	PA
3	11-2-66	KHK	PA
8	12-9-73	PAB	PA
7	12-2-58	Gjo	PA
1	18-1-67	PA	PA

Radiometer		COPENHAGEN	
72 EMDRUPVEJ NV		Establisher	
WAVE ANALYZER		1597-A2	
DIAGRAM VI		Type FRA 30	
From no. 8993		to no.	
Established at		11-12-64	
Malesdot		Egns. EA 11-12-64	
Konst. 11-12-64		Name	

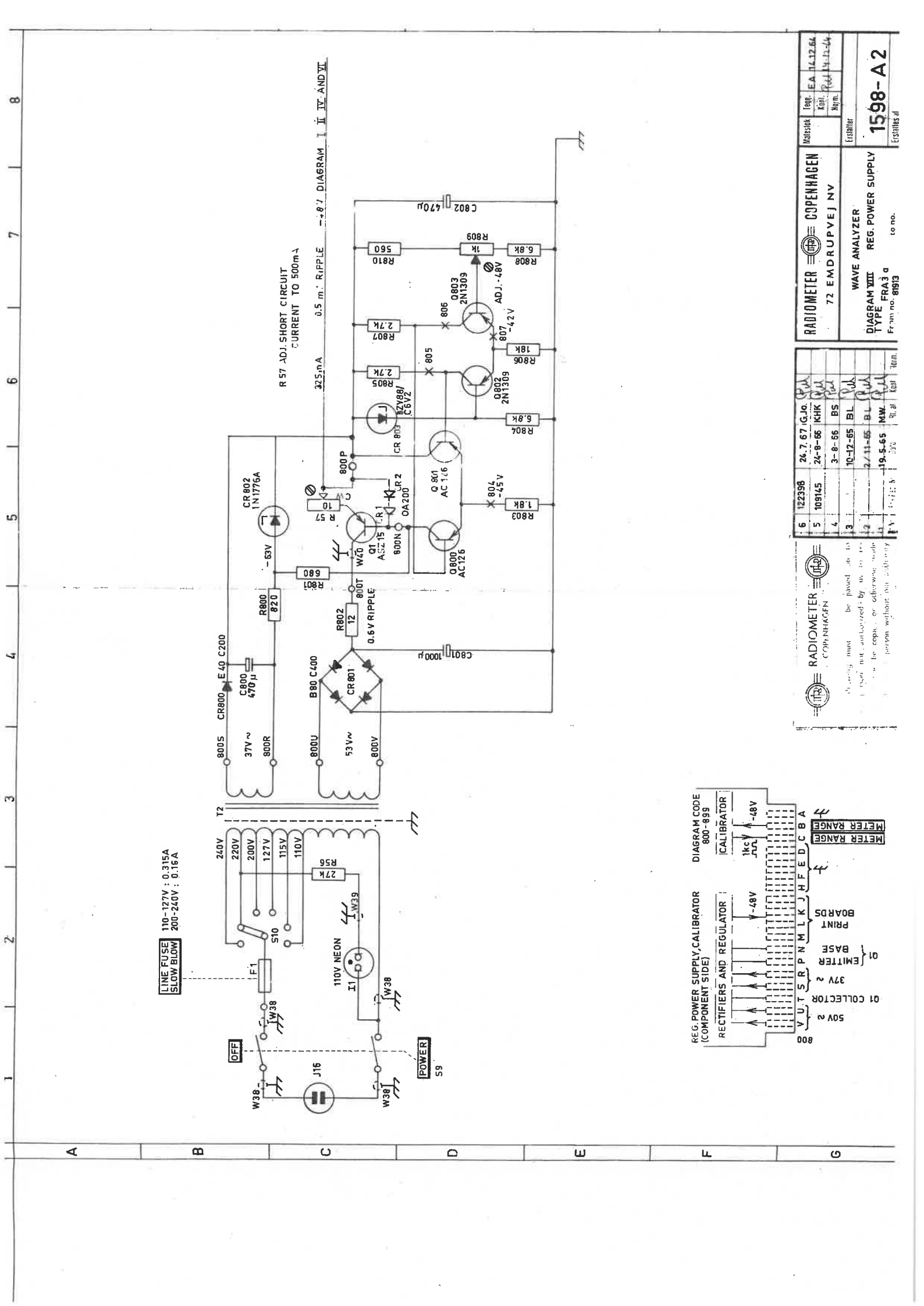

LINE FUSE 110-127V : 0.315A  
SLOW BLOW 200-240V : 0.16A

R 57 ADJ. SHORT CIRCUIT  
CURRENT TO 500mA

32.5 mA 0.5 m. RIPPLE - 0.7 DIAGRAM I II IV AND VI

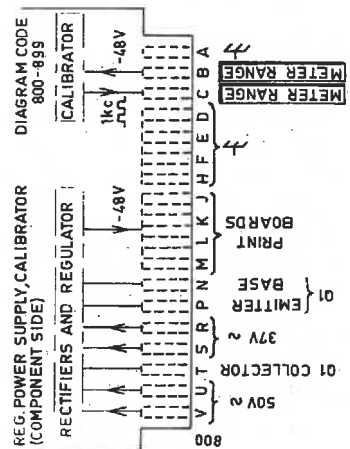

**RADIOMETER**  
COPENHAGEN

72 EMDRUPVEJ NV

WAVE ANALYZER  
REG. POWER SUPPLY

DIAGRAM VIII  
TYPE FRA 3 a

From no. 8993 to no. 8994

6	122398	24-7-67	G.10	KA					
5	109145	24-8-66	KHK	KA					
4		3-8-66	BS	KA					
3		10-12-65	BL	KA					
2		2-11-65	BL	KA					
1		19-5-65	MW	KA					

Ordering must be placed as to  
be copied or otherwise made  
person without our authority

1598-A2

Estilles of