

**IM5e
MEGOHMMETER**



OPERATING INSTRUCTIONS

Table of Contents

	page
SECTION A - INTRODUCTION	A1
SECTION B - SPECIFICATIONS	B1
SECTION C - ACCESSORIES	C1
1. Component Adapter, type IM501	C1
2. Component Jig, type KPH1	C1
SECTION D - GENERAL DESCRIPTION	D1
1. General	D1
2. Controls, Meter, and Terminals	D3
SECTION E - OPERATING INSTRUCTIONS	E1
1. Connecting the Megohmmeter after unpacking	E1
2. Operating the Megohmmeter	E1
SECTION F - CIRCUIT DESCRIPTION	F1
1. General	F1
2. Power Supply	F1
3. Switch Unit	F2
4. Vacuum-Tube Voltmeter	F3
SECTION G - MAINTENANCE	G1
1. General	G1
2. Removing the Instrument from the Cabinet	G1
3. Tube Replacement	G1
4. Adjusting the Test Voltage	G1
5. Adjusting the Feedback Resistance Network of the Vacuum-Tube Voltmeter	G1
6. Cleaning the Instrument	G2
SECTION H - PARTS LIST	H1

Megohmmeter Type IM5

Section A. Introduction

The Megohmmeter, type IM5, is a line-operated electronic measuring instrument intended for measuring resistances in the range from $1 \text{ M}\Omega$ to $100 \times 10^6 \text{ M}\Omega$. The field of application comprises measurements of insulation resistance of capacitors, transformers, cables and insulation materials, including printed circuit boards.

It is provided with a special guard circuit which renders possible measurements which require guarding, such as measurements of the leakage between two cable cores or measurements of insulation resistance in three-terminal networks.

The Megohmmeter, type IM5, is provided with the test voltages 5, 10, 20, 50, 100, 200, 500, and 1000 V dc. As the short circuit current is limited to 4 mA, the Megohmmeter, type IM5, will not be dangerous to the operator. Neither will it be damaged in the case of a short-circuit in the unknown under measurement.

The Megohmmeter, type IM5, is provided with a charging circuit which is used when measuring the insulation resistance

of capacitors. Among other things the circuit has the effect that even very large capacitors are rapidly charged.

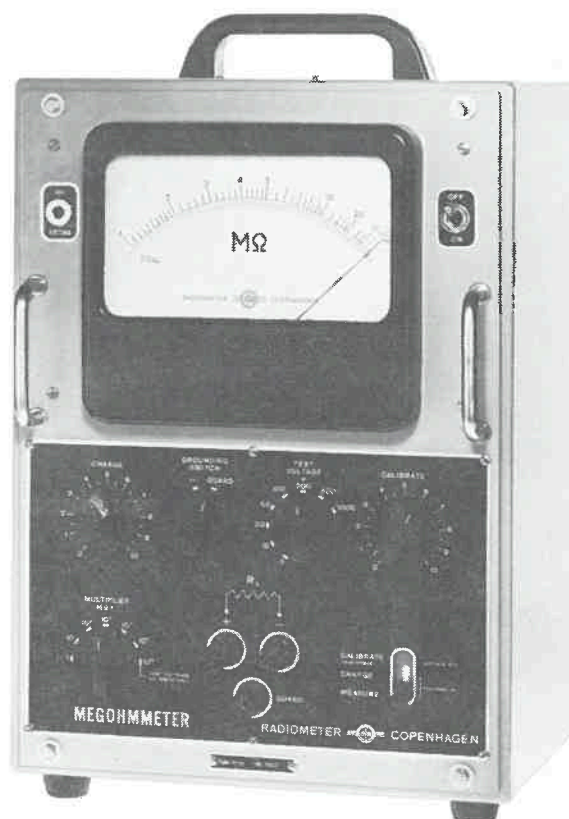

Fig.1. The Megohmmeter, type IM5

Section B. Specifications

RANGE	1 M Ω to 10 ⁸ M Ω in 7 decades for the test voltages 50, 100, 200, 500, and 1000 V dc. 1 M Ω to 10 ⁷ M Ω in 6 decades for the test voltages 5, 10, and 20 V dc.
SCALE	Calibrated in megohms from 1 M Ω to 100 M Ω .
MULTIPLIER	1, 10,, 10 ⁶ . 10 ⁶ multiplier not usable below 50 V dc.
TEST VOLTAGES	5, 10, 20, 50, 100, 200, 500, and 1000 V dc.
ACCURACY OF TEST VOLTAGES	$\pm 5\%$.
STABILITY OF TEST VOLTAGES	$\pm 0.015\%$ for $\pm 10\%$ line voltage variations.
ACCURACY	Within the scale range from 1 M Ω to 10 M Ω the following accuracy is obtainable: $\pm 3\%$ up to 10 ⁵ M Ω $\pm 4\%$ up to 10 ⁶ M Ω $\pm 5\%$ up to 10 ⁷ M Ω (not valid for test voltages below 50 V dc).
POWER SUPPLY	
<u>Voltages:</u>	110, 115, 127, 200, 220, 240 V.
<u>Line Frequency:</u>	50 Hz, or as ordered.
<u>Consumption:</u>	35 VA.
TUBE COMPLEMENT	1 EF80 (6BX6) 1 85A2 (5651) 3 EF86 (6267) 1 Z10 1 150B2 (6354) 1 OC460

DIMENSIONS

<u>Height:</u>	460 mm (18 in.)
<u>Width:</u>	285 mm (11 1/4 in.)
<u>Depth:</u>	245 mm (9 3/4 in.)

WEIGHT 13 kilos (29 lbs.)

MOUNTING AND FINISH Steel cabinet in grey enamel.

SPECIAL VERSIONS

Picosiemens Meter,
type IM5S1 Same as standard instrument, but with meter calibrated in pS.

Megohmmeter,
type IM5S2 Same as standard instrument, but provided with recorder output (350 μ A, load max. 100 Ω) and designed for panel mounting.

Megohmmeter,
type IM5S4 Same as standard instrument, but with recorder output (350 μ A, load max. 100 Ω).

Megohmmeter,
type IM5S5 Same as standard instrument, but designed for panel mounting.

Megohmmeters, for
60 Hz Line Voltage

IM5S1S7	as IM5S1,	but for 60 Hz line voltage
IM5S2S7	as IM5S2,	" " " " " "
IM5S4S7	as IM5S4,	" " " " " "
IM5S5S7	as IM5S5,	" " " " " "

ACCESSORY SUPPLIED 1 Power Cord, type 12K21 - 1.5.

ACCESSORIES AVAILABLE Component Adapter, type IM501.
Component Jig, type KPH1.

Section C. Accessories

COMPONENT ADAPTER, TYPE IM501

The Component Adapter serves to accelerate the working speed of the Megohmmeter, type IM5, so as to make it more suitable for production control.

The adapter is designed as a small guarded box with three plugs that fit into the positive and negative terminals and GUARD of the Megohmmeter. The front is provided with two clips allowing for the connection of unknowns with coaxial leads.

The adapter is guarded in the same way as the terminals of the Megohmmeter. To avoid potentials between the cabinet of the Megohmmeter and the dust cover of the component adapter, the GROUNDING SWITCH of the Megohmmeter should always be in position GUARD.

The distance between the two clips is

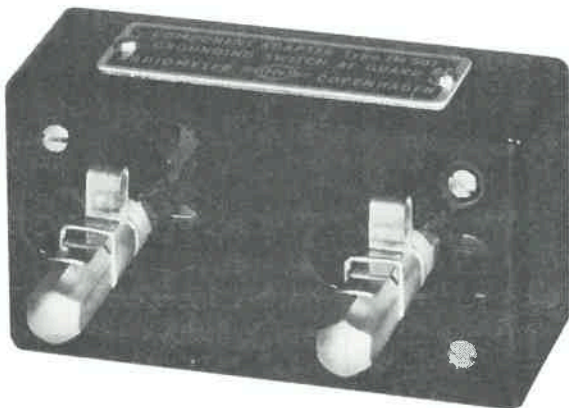

Fig.2. The Component Adapter, type IM501

variable from 35 mm to 65 mm. To change the position of the clip: loosen the hexagon nut on the stud of the holder, move the holder in the slot in the supporting plate to the desired position, and tighten the nut.

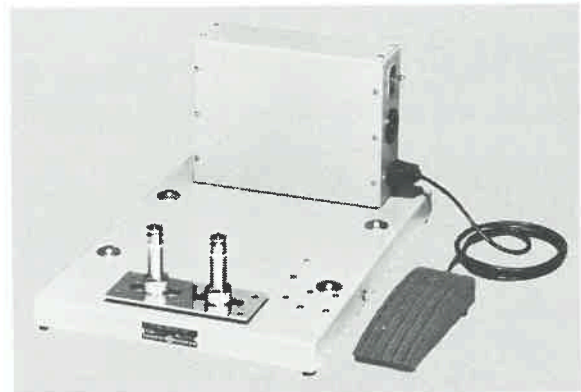

Fig.3. The Component Jig, type KPH1

COMPONENT JIG, TYPE KPH1

The Component Jig, type KPH1, is an electrically operated unit for rapid clamping of components during measurement. The terminal spacing can be varied to accommodate components of different sizes. The clamping mechanism is controlled by the function selector of the Megohmmeter so that no test voltage is applied during exchange of components. The automatic discharge feature of the Megohmmeter is preserved for increased safety in testing capacitors. The maximum operating rate depends on the measuring range and the component under test.

Section D. General Description

GENERAL

Operating Principle

The operating principle of the Megohmmeter, type IM5, appears from the simplified block diagram shown in Fig.4.

In combination with the standard resistance R_N , the resistance R_X of the un-

known forms a voltage divider across which a dc test voltage is impressed. The voltage present across the standard resistance R_N depends on the ratio between R_X and R_N and is fed to a vacuum-tube voltmeter where it gives rise to a deflection on the meter which is calibrated directly in megohms. The vacuum-tube voltmeter is of the vibrator type, so it

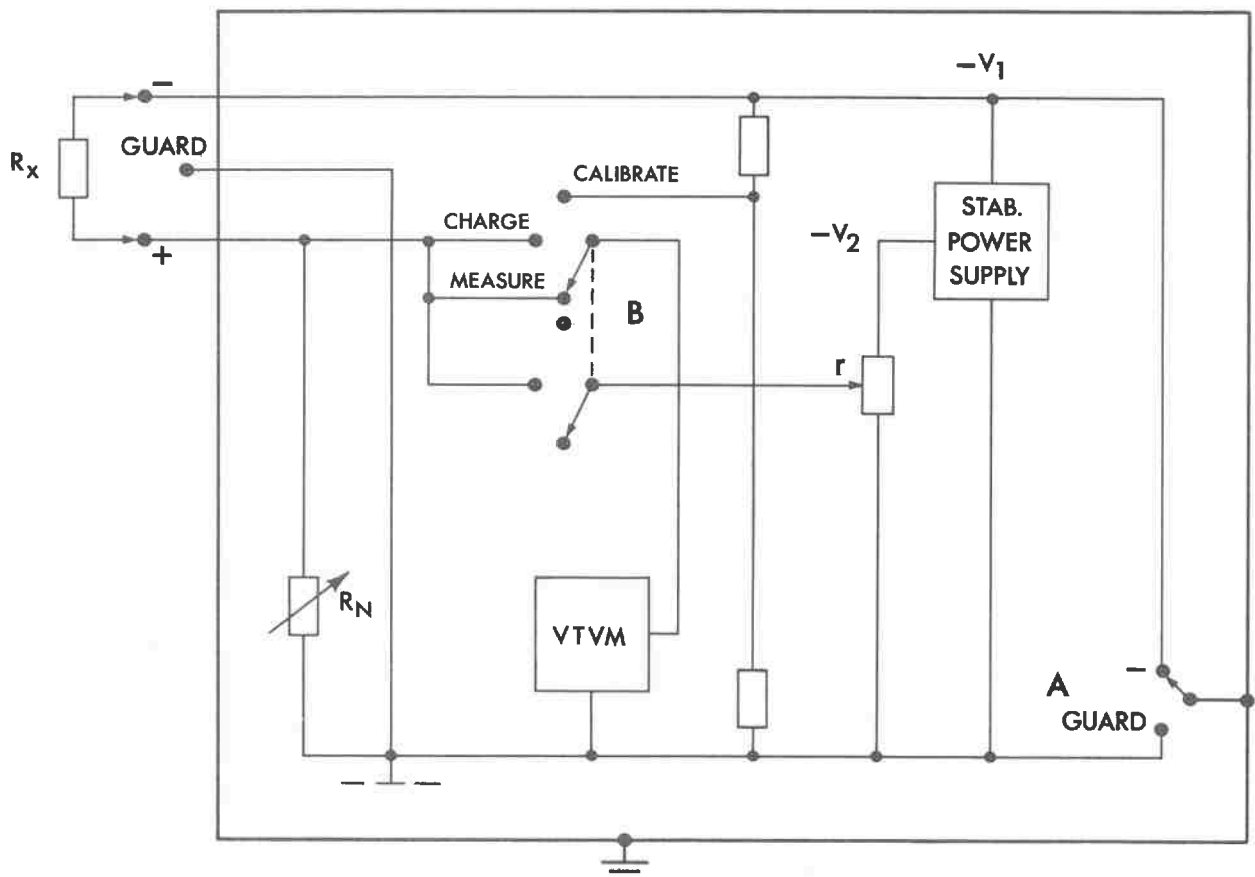

Fig.4. Simplified Block Diagram of the Megohmmeter, type IM5

has no zero drift. Full deflection is obtained when the unknown resistance R_X is 1000 times as high as the standard resistance R_N (10.000 times on the highest range).

The dc test voltage is drawn from a built-in, electronically-regulated dc source, thus eliminating the influence of line voltage variations.

When calibrating the Megohmmeter (switch B in position CALIBRATE), the input voltage of the vacuum-tube voltmeter is drawn from a voltage divider (1:1000 or 1:10.000) which is fed from the test voltage. Thus, the absolute magnitude of the test voltage will be of no importance as calibration and measurement are made at the same voltage. The amplifier of the vacuum-tube voltmeter can be so adjusted that the meter deflects to a calibration mark on the scale.

In measuring the insulation resistance of large capacitors, a special charging circuit is used. When switch B is set to CHARGE, the capacitor is charged through the resistor r instead of through the standard resistor. As the resistance r is low, the capacitor is rapidly charged. If the insulation resistance is measured after a certain time, the time can therefore, even in the case of large capacitors, be counted from the moment when the charging commences. During the charging, the vacuum-tube voltmeter is connected to the arm of the potentiometer r . When adjusting the potentiometer, it is possible to obtain a suitable deflection of the meter of the vacuum-tube voltmeter corresponding to the expected magnitude of the insulation resistance of the capacitor or to any specified limit value.

When switch B is set to MEASURE, the change in deflection will be dependent on the insulation resistance in proportion to this limit value. The standard resistance must be adjusted in accordance with the limit value.

The unknown, R_X , is connected to the positive and negative terminals which are insulated from the internal chassis so that

no leakage will occur between the terminals, but only from each of the terminals to the internal chassis. (See Fig.5, where R_1 and R_2 represent the leakage resistances from the terminals.) The sole requirement is that R_1 be reasonably high in proportion to the standard resistance R_N , which always is the case in practice.

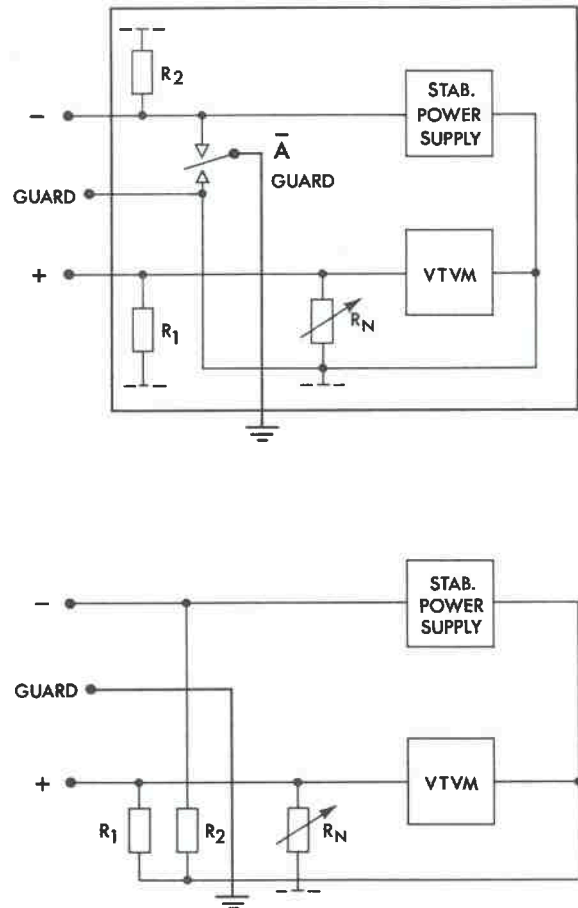

Fig.5. The Influence of the Leakage Resistances of the Insulated Terminals

The internal chassis, which is insulated from the external chassis, is connected to the terminal GUARD.

By means of switch A, the negative terminal marked " - " or the terminal GUARD can be connected to the EXTERNAL chassis. In ordinary measurement, the switch is set to " - ", thus grounding the negative terminal, to which grounded terminals of the unknown must be connected.

When switch B is in position CALIBRATE, the terminals marked + and - are dead. Furthermore, the unknown is automatically paralleled by 44 kΩ so that the operator is not exposed to danger from loaded capacitors or cables.

CONTROLS, METER, AND TERMINALS

As can be seen in Fig.6, the Megohm-

meter, type IM5, is equipped with the following controls, terminals, and meter:

Power Switch (ON-OFF)

The power switch (1) is located on the front panel of the instrument and is monitored by a lamp located in the indicating meter.

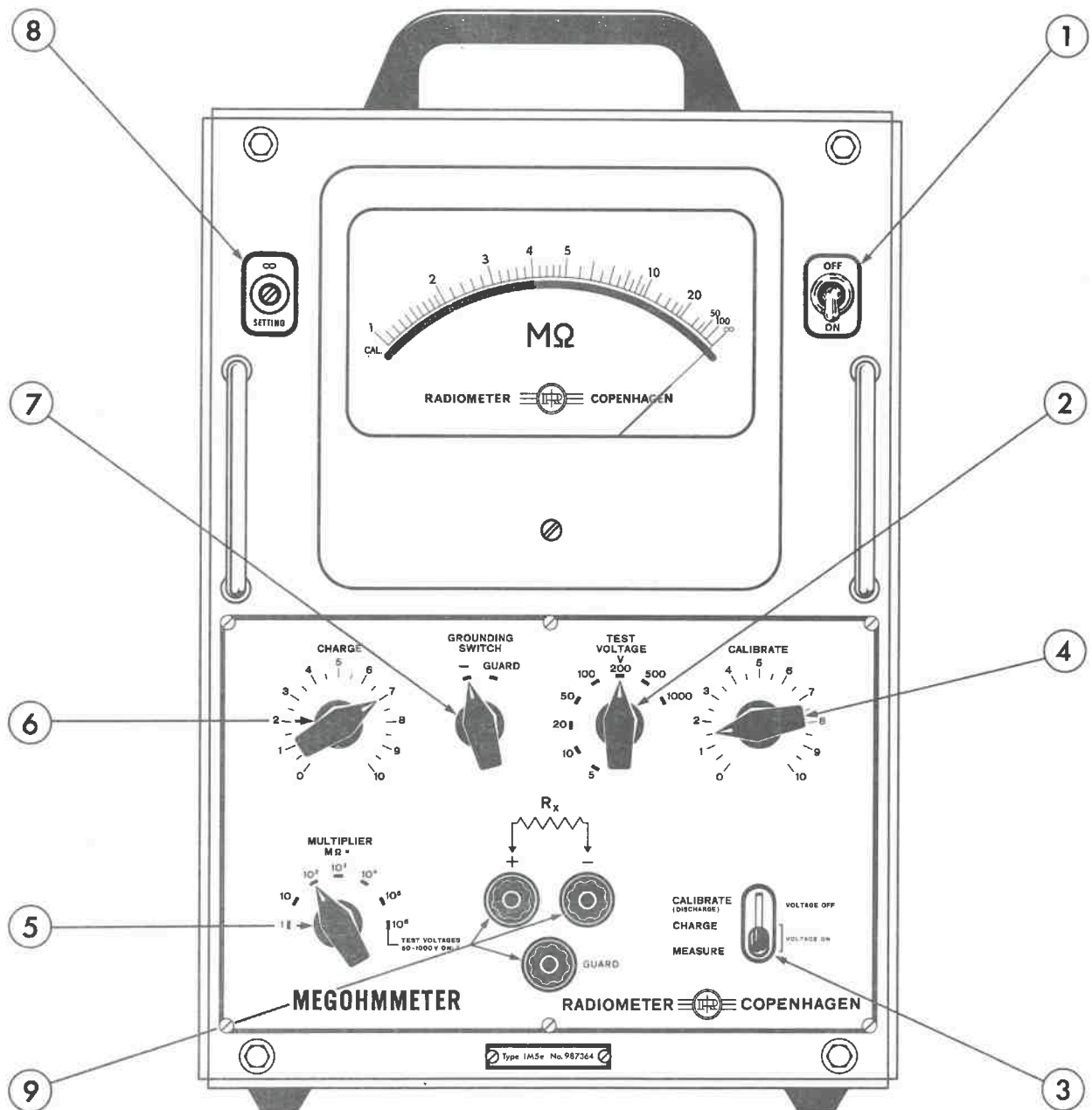

Fig.6. Front Plate of the Megohmmeter, type IM5

VOLTAGE SELECTOR

The VOLTAGE SELECTOR (2) permits selection of the test voltage from 5 to 1000 V dc in a 5-10-20 sequence.

Function Selector

The function selector CALIBRATE-CHARGE-MEASURE (3) is used to select the three operating modes of the Megohmmeter, type IM5. Calibration is performed with the function selector in position CALIBRATE. This position is also used when discharging capacitors. Charging of the capacitive unknown is accomplished by setting the function selector to CHARGE, the test voltage thus being applied to the component. Finally, in position MEASURE, the test voltage is applied to the component and permits measurements to be made.

Potentiometer CALIBRATE

The potentiometer CALIBRATE (4) is used for calibrating the instrument. Calibration is achieved when the meter deflects to the calibrating mark CAL.

MULTIPLIER Selector

The selector MULTIPLIER (5) selects the measuring range. The inscriptions 1, 10, 10^2 ... 10^6 , indicate that the meter reading must be multiplied by 1, 10, 10^2 ... 10^6 . The 10^6 multiplier cannot be used when measuring with the 5, 10, 20 V dc test voltages.

CHARGE Potentiometer

The potentiometer CHARGE (6) is used for setting the charge voltage when measuring on capacitors.

GROUNDING SWITCH

The GROUNDING SWITCH (7) permits different types of grounding as detailed in SECTION E, Fig.9.

Infinity SETTING Potentiometer

The Potentiometer ∞ SETTING (8) is used for adjusting the deflection to infinity on the indicating meter.

Terminals

The three terminals (9) are regular banana-type jacks and provide for connection of the unknown.

The polarity of the terminals is as follows:

The black terminal (R_X^-) is negative, the red terminal (R_X^+) is positive, and the third terminal (GUARD) is a guard terminal. (See SECTION E, Fig.9, for further details.)

Meter

The meter is mirror-backed and provided with a knife-edge pointer, thus ensuring accurate reading free from parallax.

It is calibrated from 1 to infinity. The meter reading must be multiplied by the selector MULTIPLIER's reading to give the value of the component under test.

Line Voltage Receptacle, Fuse, and Voltage Selector

The line voltage receptacle, fuse, and voltage selector are all located on the rear of the instrument.

Section E. Operating Instructions

CONNECTING THE MEGOHMMETER AFTER UNPACKING

The instructions below should be followed when using the instrument for the first time:

1) Make sure that the line voltage selector of the instrument is set to the voltage available. Check that the appropriate fuse is being used.

Use a 160 mA slow-blow fuse for a line voltage between 200 and 240 V and a 315 mA for 110-127 V operation. The Megohmmeter is set to a line voltage of 220 V when leaving the factory and is provided with two 160 mA fuses. To switch to another line voltage, proceed as follows:

First unscrew the fuse, then withdraw the disc indicating the line voltage; next rotate it until the desired line voltage is visible, and finally remount it and tighten the fuse.

Remember to change the fuse when switching from 110-127 V to 200-240 V and conversely.

2) Make sure that the line frequency stated at the receptacle corresponds to the line frequency available. (The Megohmmeter is generally supplied for operation on 50 Hz. On request, however, it can be supplied for operation on 60 Hz).

3) Ground the jack on the left-hand panel.

4) Check the mechanical setting of the meter. If the needle does not rest at ∞ , it is adjusted by means of the slotted screw on the meter.

5) Connect the instrument to the power line by means of the power cord supplied.

6) Switch on the instrument.

7) Let the instrument warm up for 1-2 hours so that moisture, if any, can evaporate.

8) Set the VOLTAGE SELECTOR to 50 volts, the MULTIPLIER selector to 10^6 , and the function selector to MEASURE.

9) Without connecting an unknown, see if the meter deflects to ∞ . If not, adjust the potentiometer ∞ SETTING with a screwdriver until the needle indicates infinity.

10) The Megohmmeter is now ready for use.

OPERATING THE MEGOHMMETER

Connection and Initial Adjustment

1) Ground the jack on the left-hand panel. Connect the instrument to the power line by means of the power cord.

2) Switch on the instrument.

3) Let the instrument warm up for several minutes.

4) Set the desired test voltage with the VOLTAGE SELECTOR.

5) Set the function selector to CALIBRATE.

6) Set the potentiometer CALIBRATE so that the meter deflects to the calibrating mark CAL.

Note: On the range $\times 10^6$, the calibration may deviate a little from the calibration on the ranges $\times 1, \times 10, \dots, \times 10^5$.

When changing over to, or from, the range $\times 10^6$, the instrument should be recalibrated, if the deviation is unacceptable. A recalibration should also be made when changing the test voltage.

Guarding

The principle of the guarding system appears from Figs. 7 and 8. Fig.7 illustrates a setup for measuring the specific resistance of an insulating material. The external guard electrode 3, which is connected to the GUARD terminals, is intended for guarding against leakage currents along the surface of the insulating material between the electrodes 1 and 2. Switch A (GROUNDING SWITCH) is in position -. In the equivalence diagram, leakage resistance is shown instead of the leakage current proper. It will be seen that R_{2-3} loads the power supply; however, this is not important if only R_{2-3} is greater than about 2 MΩ. R_{2-4} is of no importance because the negative terminal is grounded. R_{1-3} shunts the resistance standard, but

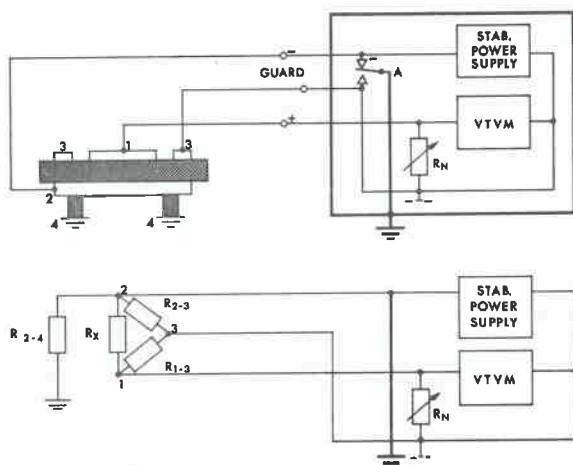

Fig.7. Guarding when measuring Specific Resistances

if R_{1-3} is of a reasonably high value in proportion to R_N (e.g. 100 times higher than R_N), the shunting will not seriously affect the measured result.

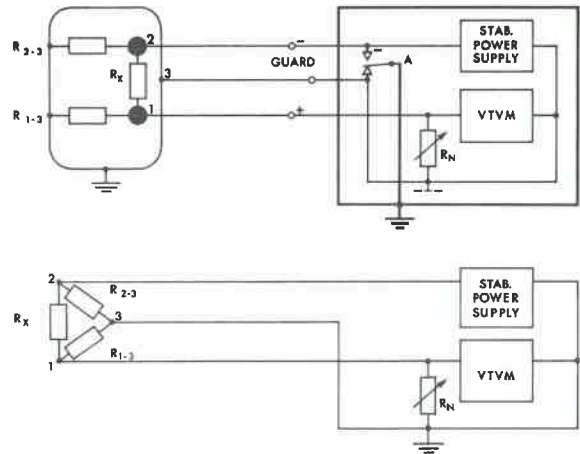

Fig.8. Guarding when measuring Leakage between two Cable Conductors

Fig.8 shows a setup for measuring the direct leakage between two conductors in a cable. The conductors 1 and 2 are connected respectively to the positive and negative terminals, while the jacket 3 is connected to the terminal GUARD. The A switch (GROUNDING SWITCH) is in position GUARD. It appears from the equivalence diagrams that the leakage resistances R_{1-3} and R_{2-3} from the conductors 1 and 2 to the jacket 3 do not affect the result of measurement. R_{2-3} loads the power supply, but this is not important if only R_{2-3} is greater than 2 MΩ. R_{1-3} shunts the resistance standard R_N , but if the value of R_{1-3} is reasonably high in proportion to R_N (e.g. 100 times higher than R_N), the shunting will not seriously affect the measuring result.

Note: There is a potential difference between the negative terminal and the cabinet when the GROUNDING SWITCH is in position GUARD.

Measuring Insulation Resistances (Capacitive Unknowns)

General:

When measuring on capacitive unknowns or large high-quality capacitors, an ex-

tremely high stability of the test voltage is required. Owing to the high insulation resistance of the unknown, the standard resistor R_N must have a high value (the ranges $\times 10^5$ or 10^6) in order to obtain a reasonable deflection on the meter. This involves a high time constant, which depends on the unknown and the resistance standard. A change in the test voltage will be transferred directly to the input of the vacuum-tube voltmeter without being subjected to the voltage division which generally occurs in the case of purely ohmic unknowns. Owing to the high time constant, however, it will be long before the voltage transferred to the vacuum-tube voltmeter dies away, and the meter pointer will consequently make jerky movements when the instrument is connected to an unstable power line.

Measuring Procedure:

At a test voltage of, for instance, 1000 V, a change in voltage of 0.001% due to a line voltage variation of 1%, will have the effect that a voltage of 10 mV is transferred to the input of the vacuum-tube voltmeter. As the sensitivity on the ranges up to $\times 10^5$ M Ω inclusive is 1 V for full deflection (the 1 M Ω graduation mark), the transferred voltage will amount to 1% of full deflection. On the range $\times 10^6$ M Ω , the sensitivity has been increased to 100 mV for full deflection, so that the voltage transferred will now amount to 10% of the input voltage corresponding to full deflection. Similar conditions apply to the other test voltages.

From this it appears that it is advantageous to use the range $\times 10^5$ M Ω as much as possible, i.e. to utilize the meter scale up to the 100 M Ω graduation mark before switching to the range $\times 10^6$ M Ω .

- 1) Prepare the instrument as above.
- 2) Connect the unknown to the terminals + and -, and the guard terminal, if any, of the unknown to the terminal GUARD as shown in Fig.9. (The function selector in position CALIBRATE.)
- 3) Set the GROUNDING SWITCH as shown in Fig.9.

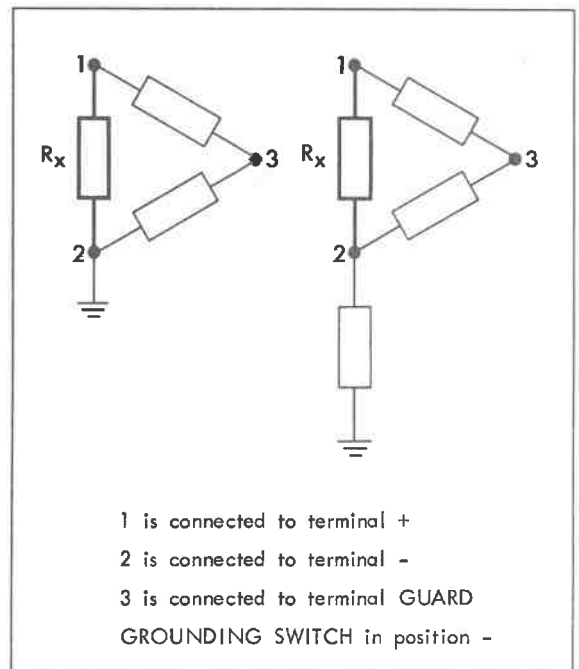
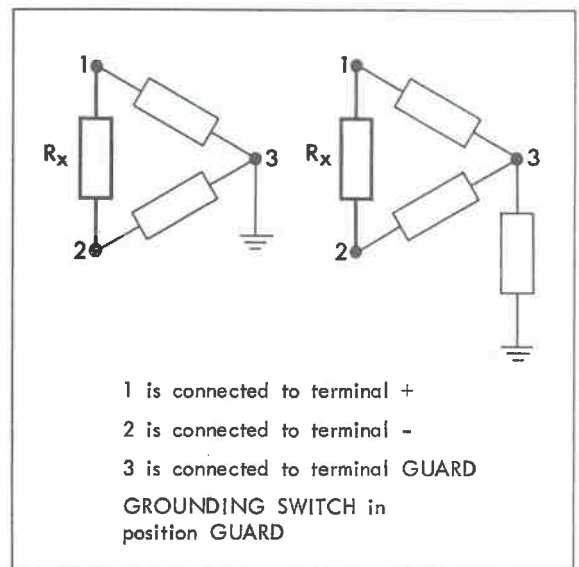
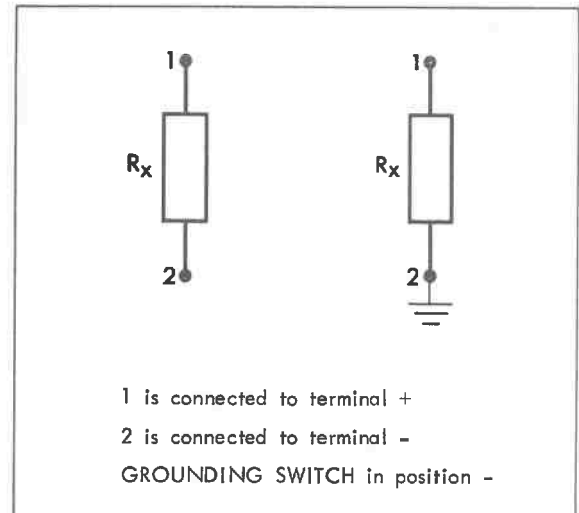

Fig.9. How to connect the Unknown

4) Set the function selector to CHARGE.

5) Set the MULTIPLIER selector and the potentiometer CHARGE so that the range and the meter reading correspond to the expected resistance value or the limit value specified.

6) Set the function selector to MEASURE

Note: If measurement of the insulation resistance after a certain time is desired, leave the function selector in position CHARGE during the period required.

7) The meter will deflect to the right if the insulation resistance is higher than the value mentioned in item 5, and to the left if it is below this value.

Note: In the two upper ranges, the pointer may jump a little at first because of frictional electricity in the function selector.

8) When the pointer has come to a rest, the resistance value is determined by multiplying the meter reading by the multiplication factor to which MULTIPLIER has been set.

9) After measuring, set the function selector back to CALIBRATE. The unknown

has now been discharged and can be removed.

Measuring Insulation Resistances (Non-Capacitive Unknowns)

1) Prepare the instrument as above.

2) Connect the unknown to the terminals + and -, and the guard terminal, if any, of the unknown to the terminal GUARD, as shown in Fig 9. (The function selector in position CALIBRATE.)

3) Set the GROUNDING SWITCH as shown in Fig. 9.

4) Set the MULTIPLIER selector in accordance with the expected value of resistance.

5) Set the function selector to MEASURE.

6) Set the MULTIPLIER selector so that a suitable deflection is obtained on the meter - preferably within the scale range 1-10 MΩ.

7) The resistance value of the unknown is obtained by multiplying the meter reading by the multiplication factor to which MULTIPLIER has been set.

8) After measuring, set the function selector back to CALIBRATE and remove the unknown.

Section F. Circuit Description

GENERAL

The Megohmmeter, type IM5, consists essentially of three units, viz., a power supply, a switch unit, and a vacuum-tube voltmeter. The electric operation of these units is described in detail below. The complete circuit diagram of the instrument is appended to the instructions.

POWER SUPPLY

By means of a voltage selector, the primary of the transformer T1 can be set to any of the voltages 110, 115, 127, 200, 220, or 240 V. Furthermore, the primary has a tap of 10 V. By moving the lead that is connected to the zero of the winding to this tap, the Megohmmeter can be adapted to voltages that are 10 V below the nominal ones.

The voltage from one of the secondaries of the line transformer is rectified in the bridge rectifier CR5 and, via the filter C17 and R47 and the dropping resistor R46, fed to the voltage-regulator tube V5 across the anode of which a +150 volt dc voltage is drawn for operating the vacuum-tube voltmeter. The voltage-regulator tube V4 is operated on +150 volts and gives off a dc voltage of +85 volts which is used as reference voltage in the electronic voltage-regulator circuit.

The second secondary of the line trans-

former is provided with several taps from which it is possible by means of the switch VOLTAGE SELECTOR (S3) to select the ac voltage corresponding to the desired test voltage. The ac voltage is fed from the switch to the voltage-doubler rectifier CR6, CR7, C19, and C20. The positive terminal of the rectifier is connected to the anode in the series-regulator tube V6, while the negative terminal is connected to the binding post E2. The necessary degree of stabilization of the test voltage is obtained by regulating the internal resistance of the series-regulator tube V6 so that it picks up a higher plate voltage in case of an increasing voltage from the voltage-doubler rectifier circuit and vice versa. By this means, the test voltage can be kept constant.

By means of the VOLTAGE SELECTOR (S3), the negative terminal of the voltage-doubler rectifier is coupled to a resistance network (R49 to R58), the other end of which is coupled to the reference voltage +85 volts. As the reference voltage is constant, any change in the test voltage will give rise to a certain error voltage across the output of the resistance network which is connected to the emitter in the transistor Q1. The collector voltage is drawn across a tap of the resistance network. The error voltage amplified by the transistor is fed to the grid of the series regulator tube V6 via a

compensation "diode", tube V7. The compensation "diode" is intended for the cancellation of heater voltage variations, if any. As a definite change of the heater voltage is the equivalent of a definite change of the cathode potential referred to the other electrode potentials, the operating point of the series regulator tube would be displaced in the absence of the compensation "diode".

To obtain an optimal stabilization of the test voltage, the screen grid voltage of the series regulator tube is drawn from the reference-voltage source.

A third secondary gives off voltage for operating the vibrator of the vacuum-tube voltmeter. Furthermore, a dc voltage is supplied after rectification for use in the charging circuit. (See items Voltage Selector and Charge Potentiometer.)

The fourth secondary supplies filament current for all tubes and dial lamps. Furthermore, the winding is loaded with the potentiometer ∞ SETTING (R63), which is used when setting the ∞ deflection of the meter. See item VACUUM-TUBE VOLT-METER.

SWITCH UNIT

A description of the operation of the switches, potentiometers, etc., of the switch unit is given below.

Function Selector

When the function selector is in position CALIBRATE, a calibrating voltage is fed to the input of the vacuum-tube voltmeter. The calibrating voltage is obtained by a voltage division of the test voltage of 1000:1 (the resistors R35 and R36) which is drawn from the power supply. When the MULTIPLIER switch S2 is in position $\times 10^6$, a 10.000:1 voltage division occurs between resistors R35 and R36 paralleled by R37. To avoid shunting of the voltage divider with the resistance standards R27 to R31 of the switch MULTIPLIER S2, these standards are automatically disconnected by means of the function selector S4 during the calibration procedure.

In position CALIBRATE each of the binding posts E1 and E2 is connected to the internal chassis through R33 and R34, respectively. In this way the unknown is short-circuited with 44 k Ω . In the position CHARGE, the input of the vacuum-tube voltmeter is connected to the arm of the potentiometer CHARGE (R38) so that a variable input voltage can be fed to the vacuum-tube voltmeter. The binding post E1 is connected to the arm of the potentiometer through the resistor R32. As the total test voltage is fed to the binding post E2, the said resistor is used to protect the contacts of the function selector if the unknown is a capacitor, or if a short circuit occurs in the unknown.

In position MEASURE, the connection to the arm of the potentiometer CHARGE R38 is cut off. To avoid leakage currents, the arm is connected to the internal chassis. For the same reason, the output of the voltage divider for the calibrating voltage (R35, R36, and R37) is connected to the internal chassis. The binding post E1 has been connected directly to the input of the vacuum-tube voltmeter, the resistor R32 being short-circuited so that it does not affect the measurement. As the resistance standard (R27 to R31) now is connected, the test voltage is divided between the resistance of the unknown and the standard resistance. The voltage resulting from the voltage division is present across the terminal E1 and is fed to the input of the vacuum-tube voltmeter.

VOLTAGE SELECTOR

As mentioned above, the switch S3 is used for selecting the tap of the line transformer and the resistance network (R49 to R58) corresponding to the test voltage desired. Furthermore, the amplification of the vacuum-tube voltmeter is changed in accordance with the test voltage as the correct tap of the feedback resistance network (R19 to R25) is selected.

At the same time, the dropping resistors in the charging voltage circuit (R39 to R43) are changed so that the charging

voltage fed to the potentiometer CHARGE is set in accordance with the desired test voltage.

MULTIPLIER Switch

The value of the resistance standard is set by means of this switch. In the position $\times 10^5$ and $\times 10^6$, where all physical resistance standards are disconnected, the resistance standard is represented by the input impedance of the vacuum-tube voltmeter of 100 M Ω .

The range $\times 10^6$ has been obtained by increasing the sensitivity of the vacuum-tube voltmeter 10 times. This is done by transferring the selection of the tap corresponding to the test voltage desired to a section of the VOLTAGE SELECTOR other than that used for the ranges $\times 1$, $\times 10$, $\times 10^5$. This changing over of the switch section is brought about independently of the actual setting of the VOLTAGE SELECTOR by means of a set of contacts in the MULTIPLIER switch S2, if only the latter is in position 10^6 .

In a similar way the charging circuit is changed, as the charging voltage must be reduced to the same degree as the sensitivity of the vacuum-tube voltmeter is changed in the range $\times 10^6$. By means of a set of contacts in the MULTIPLIER switch S2, a resistance R44 is coupled in parallel across the CHARGE potentiometer R38, thus decreasing the voltage across the potentiometer about 10 times. The parallel coupling is maintained irrespective of the setting of the switch VOLTAGE SELECTOR when only the MULTIPLIER switch is in position $\times 10^6$.

As mentioned above, the calibrating voltage is decreased to the same degree as the sensitivity is increased in the range $\times 10^6$. By means of a set of contacts in the MULTIPLIER switch S2, the resistor R37 is connected in parallel across the resistor R36 so the division ratio is changed from 1000:1 to 10.000:1. The parallel coupling is maintained irrespective of the actual setting of the VOLTAGE SELECTOR, if only the MULTIPLIER switch is in position $\times 10^6$.

Note: The 10^6 multiplier cannot be utilized in the test voltage ranges 5, 10, and 20 V dc.

CALIBRATE Potentiometer

By means of the potentiometer CALIBRATE (R26), the feedback factor - and consequently the sensitivity - can be fine-adjusted so that when calibrating, it is always possible to obtain the correct sensitivity of the vacuum-tube voltmeter.

CHARGE Potentiometer

The CHARGE potentiometer R38 is used for setting the charge voltage fed to the input of the vacuum-tube voltmeter when the function selector is in position CHARGE.

Binding Posts

The unknown is connected across the binding posts E1 and E2, marked + and - respectively. The lower end of the resistance standard (R27 to R31), which is connected to the internal chassis, has been connected to the binding post GUARD E3. The proper use of the guarding system is described on page E2.

GROUNDING SWITCH

The switch S1 is used for connecting the binding post E2 or E3 to the external chassis and accordingly to ground.

VACUUM-TUBE VOLTMETER

The dc voltage, which during measurement is present across the resistance standard as a result of the voltage division between the standard and the resistance of the unknown, is fed to the input of the vacuum-tube voltmeter. Tube V1 is a neon lamp which is used to protect the vacuum-tube voltmeter and the resistance standards against overvoltages in case of short circuit in the unknown. The dc voltage is fed to a vibrator (Z1) via the input filter, C1 to C3, R3 and R4, which removes the hum

voltages if any. In the vibrator, the dc voltage is transformed into an ac voltage. The two resistors R1 and R2 protect the vibrator contacts. The input impedance of the vacuum-tube voltmeter of 100 M Ω is composed of the impedance of the input filter and the dynamic input impedance of the vacuum-tube voltmeter. The latter is due to the grid leak resistor R5, the grid capacitor C4, and the trimmer C5, which, when exposed to a square-wave voltage, give an impedance of about 90 M Ω . The impedance is dependent on the frequency. At the factory, however, it is set to the line frequency on which the instrument is to operate, generally 50 Hz. The vacuum-tube voltmeter, which incorporates the tubes V2 and V3, is provided with negative feedback. The magnitude of the negative feedback is determined by the output of the feedback resistance network R19 to R25, to which the cathode

of tube V2 is connected. Within a certain narrow range, the potentiometer CALIBRATE provides for changing that part of the output current from tube V3 that is fed through the feedback resistance network. By this means a fine adjustment of the feedback, and accordingly of the sensitivity, is obtained. The potentiometer R14 is used for adapting the feedback resistance network.

The diodes CR1 and CR2, used in the rectifier circuit of the indicating meter, are silicon diodes eliminating the influence of temperature variations on the calibration of the meter.

From the potentiometer ∞ SETTING an ac voltage is fed to the grid of tube V2 through a small air capacitor. When adjusting the voltage supplied, a residual reading on the indicating meter can be outbalanced.

Section G. Maintenance

GENERAL

The Megohmmeter, type IM5, is a very delicate instrument, so unnecessary repairs or attempts to improve the accuracy should not be made.

Such repairs as may become necessary should only be made by skilled persons provided with adequate measuring equipment and tools to ensure a proper repair.

REMOVING THE INSTRUMENT FROM THE CABINET

The instrument can be removed from the cabinet when the four hexagon-head screws on the front panel have been removed.

TUBE REPLACEMENT

Generally the tubes need not be replaced until they cause some kind of trouble. All tubes are readily accessible when the instrument has been removed from the cabinet. Tubes with average characteristics can be used for any replacement.

ADJUSTING THE TEST VOLTAGE

1) Remove the instrument from the cabinet. To prevent accidents, set the GROUNDING SWITCH to GUARD, so that no voltage is present between the insulated chassis and the front panel.

2) Set the VOLTAGE SELECTOR to 1000 V and switch on the instrument.

3) By means of the potentiometer P2 (R50), the test voltage is so set within the range $1000\text{ V} \pm 50\text{ V}$ that the anode voltage of the series regulator tube is within $275\text{ V} \pm 25\text{ V}$. It is assumed that the line voltage adopts the nominal value. When measuring the test voltage, an external vacuum-tube voltmeter is connected across the terminal - and the terminal GUARD, and the function selector is set to MEASURE. When measuring the plate voltage of the series regulator tube, the vacuum-tube voltmeter is connected between the chassis (GUARD) and pin No.6 of tube No.6.

4) Next the VOLTAGE SELECTOR is set to the test voltages 500, 200, 100, 50, 20, 10, and 5 V in the said order of succession. The test voltages should then adopt the nominal value $\pm 5\%$, and the plate voltage of the series regulator tube should be $275\text{ V} \pm 25\text{ V}$. In the case of the 50 or 5 V test voltages, however, the plate voltage of the series regulator tube is $325\text{ V} \pm 25\text{ V}$.

ADJUSTING THE FEEDBACK RESISTANCE NETWORK OF THE VACUUM-TUBE VOLTMETER

This adjustment should always be made when the tubes of the vacuum-tube voltmeter have been replaced, and if the cal-

ibrations of the vacuum-tube voltmeter are not identical in the ranges $\times 10^5$ and $\times 10^6$ at a test voltage of 50 V.

- 1) Remove the instrument from the cabinet.
- 2) Set the GROUNDING SWITCH to GUARD so that no voltage is present between the insulated chassis and the front panel. The instrument must be grounded during the adjustment. The ground lead is conveniently connected to the terminal GUARD.
- 3) Set the VOLTAGE SELECTOR to 50 volts and the MULTIPLIER to $\times 10^6$.
- 4) Set the operating switch to MEASURE and make sure that the meter reads ∞ . If not, adjust the potentiometer ∞ SETTING until the meter reads ∞ .
- 5) Then set the function selector to CALIBRATE. Set the potentiometer P1 (R14) so that the meter readings are identical in the positions $\times 10^5$ and $\times 10^6$ of the MULTIPLIER switch. Then observe whether the

potentiometer CALIBRATE is approximately at the center of its range of settings (from 3 to 7) when the potentiometer is so set that the meter pointer deflects to the calibrating mark CAL. If not, set the potentiometer to its center position (5) and change the value of the resistor R13, placed between one end of the potentiometer R26 and the chassis, so that the meter deflects approximately to the calibrating mark CAL.

CLEANING THE INSTRUMENT

Owing to the heavy demands on the insulation, the instrument should be inspected and cleaned now and then. Remove dust, dirt and grease from the terminals +, -, and GUARD. Inside the instrument especially the binding posts the function selector, the GROUNDING SWITCH, and the VOLTAGE SELECTOR should be kept clean so that there is no leakage from the live parts to the chassis.

Section H. Parts List

In the following parts list a group code prefix number is used. To facilitate the use of this code, the different types of parts and their corresponding group code prefixes are listed below:

Standard resistors	100- to 139-
Precision resistors	140- to 152-
Non-linear resistors	160-
UHF resistors	170- to 172-
Carbon potentiometers	180- to 185-
Wire-wound potentiometers	190- to 195-
Mica capacitors	200- to 208-
Ceramic capacitors	210- to 214-
Paper capacitors	220- to 222-
Metal-paper capacitors	224- to 229-
Plastic capacitors	240- to 245-
Electrolytic capacitors	260- to 267-
Variable capacitors	280- to 286-
Special tubes	310-
Rectifiers	340- to 341-
Diodes	350-
Transistors	360-
Integrated circuits	364-
Lamps, batteries, fuses	400- to 486-
Switches	500- to 580-
Coils, coil material and transformers	700- to 785-

As we are continually improving our instruments, it is important, when ordering spare parts, that you include the following information:

- The code number and description of the part
- The circuit reference from the wiring diagram
- The complete type designation of your instrument
- The serial number of your instrument

Please note that the position of any part can easily be found by referring to the last column of the parts list. This indicates on which figure the part can be located.

^x indicates special parts manufactured by Radiometer.

H2

CAPACITORS

Designation	Type	Value	Code No.
C1	polystyrene	4.7 nF 5% 630 V	243-125
C2	polystyrene	4.7 nF 5% 630 V	243-125
C3	polystyrene	4.7 nF 5% 630 V	243-125
C4A	ceramic	100 pF 5%	210-310
C4B	ceramic	10 pF 5%	210-210
C5	trimmer	25 pF	285-008
C6	polystyrene	4.7 nF 5% 630 V	243-125
C7	polyester	1.8 nF 10% 400 V	240-418
C8	electrolytic	220 μ F 6/8 V	260-006
C9	polyester	10 nF 10% 400 V	240-510
C10	electrolytic	2 x 22 μ F 350/400 V	261-015
C11	polyester	2.7 nF 10% 400 V	240-427
C12	polyester	0.1 μ F 10% 400 V	240-610
C13	electrolytic	220 μ F 6/8 V	260-006
C14	polyester	0.47 μ F 10% 400 V	240-647
C16	electrolytic	47 μ F 12/15 V	260-003
C17	electrolytic	2 x 33 μ F 500/550 V	261-028
C18	polyester	0.1 μ F 10% 400 V	240-610
C19	paper	0.27 μ F 1000 V	220-007
C20	paper	0.27 μ F 1000 V	220-007
C21	paper	0.27 μ F 1000 V	220-007
C22	electrolytic	220 pF 50 /60 V	260-017
C23	polyester	0.47 μ F 10% 400 V	240-647
C24	polyester	0.47 μ F 10% 400 V	240-647

DIODES AND RECTIFIERS

Designation	Type	Code No.
CR3	diode BAX16	350-023
CR4	diode BAX16	350-023
CR5	rectifier B390C90	340-012
CR6	rectifier E1000C5	340-101
CR7	rectifier E1000C5	340-101

H3

CR8	diode OA81	350-009
-----	------------	---------

TERMINALS

Designation	Type	Code No.
E1	binding post, black	807-036
E2	binding post, black	807-036
E3	binding post, black	807-036

FUSES

Designation	Type	Code No.
F2	fuse, 200 mA for 220 V	450-013
	fuse, 400 mA for 115 V	450-016

LAMP

Designation	Type	Code No.
I1	pilot lamp, 6 V 3 W	400-601
I2	pilot lamp, 6 V 3 W	400-601

PLUGS

Designation	Type	Code No.
J1	phone jack	803-241
J2	line receptacle	802-101
J3	phone jack	803-241

COILS

Designation	Type	Code No.
L1	filter choke, 1000 H 2 mA	760-027

METER

Designation	Type	Code No.
x M1	meter, 350 μ A, with scale	482-074

H4

TRANSISTORS

Designation	Type	Code No.
Q1	transistor OC200 (BCZ10)	360-013

RESISTORS

Designation	Type	Value	Code No.	Shown Fig.
R1	carbon film	22 k Ω 5% 0.5 W	100-522	
R2	carbon film	22 k Ω 5% 0.5 W	100-522	
R3	carbon film	4.7 M Ω 5% 0.5 W	100-747	
R4	carbon film	4.7 M Ω 5% 0.5 W	100-747	
R5	metal film	50 M Ω 5% 0.5 W	143-013	
R6	carbon film	1 M Ω 5% 0.5 W	100-710	
R7	carbon film	15 k Ω 5% 0.5 W	100-515	
R8	carbon film	150 k Ω 5% 0.5 W	100-615	
R9	carbon film	100 k Ω 5% 0.5 W	100-610	
R10	carbon film	10 k Ω 5% 0.5 W	100-510	
R11	carbon film	10 M Ω 5% 0.5 W	100-810	
R12	carbon film	3.3 M Ω 5% 0.5 W	100-733	
R13	carbon film	680 Ω 5% 0.5 W	100-368	
R14	wire-w. pot.	100 Ω 2 W	191-022	
R15	carbon film	10 k Ω 5% 0.5 W	100-510	
R16	carbon film	390 Ω 5% 0.5 W	100-339	
R17	carbon film	33 k Ω 5% 0.5 W	100-533	
R18	carbon film	2.2 k Ω 5% 0.5 W	100-422	
x R19	wire-wound	1020 Ω 1% 0.1 W	2909-A5	10
x R20	wire-wound	612 Ω 1% 0.1 W	2910-A5	10
x R21	wire-wound	204 Ω 1% 0.1 W	2911-A5	10
x R22	wire-wound	102 Ω 1% 0.1 W	2912-A5	10
x R23	wire-wound	61.2 Ω 1% 0.1 W	2913-A5	10
x R24	wire-wound	20.4 Ω 1% 0.1 W	2914-A5	10
x R25	wire-wound	10.2 Ω 1% 0.1 W	2915-A5	10
R26	wire-w. pot.	1 k Ω lin. 2 W	191-025	
R27	metal film	10.1 M Ω 1% 0.5 W	143-010	
R28	metal film	1 M Ω 1% 0.5 W	140-164	

H5

R29	metal film	100 k Ω 1% 0.5 W	140-036	
R30	metal film	10 k Ω 1% 0.5 W	140-089	
R31	metal film	1 k Ω 1% 0.5 W	140-084	
R32	carbon film	22 k Ω 5% 0.5 W	100-522	
R33	carbon film	22 k Ω 5% 0.5 W	100-522	
R34	carbon film	22 k Ω 5% 0.5 W	100-522	
R35A	metal film	2.5 M Ω 0.5% 0.5 W	143-003	10
R35B	metal film	2.5 M Ω 0.5% 0.5 W	143-003	10
R36	metal film	5 k Ω 0.5% 0.5 W	143-002	10
R37	metal film	555 Ω 0.5 % 0.5 W	143-001	10
R38	wire-w. pot.	200 Ω lin. 2 W	191-023	
R39	carbon film	2.7 k Ω 5% 0.5 W	100-427	10
R40	carbon film	5.6 k Ω 5% 0.5 W	100-456	10
R41	carbon film	15 k Ω 5% 0.5 W	100-515	10
R42	carbon film	33 k Ω 5% 0.5 W	100-533	10
R43	carbon film	68 k Ω 5% 0.5 W	100-568	10
R44	carbon film	27 Ω 5% 0.5 W	100-227	10
R45	carbon film	22 k Ω 5% 1 W	101-522	
R46	wire-wound	10 k Ω 3 W	130-510	
R47	wire-wound	10 k Ω 3 W	130-510	
R48	carbon film	2.2 M Ω 5% 0.5 W	100-722	
R49	carbon film	150 k Ω 5% 0.5 W	100-615	
R50	carbon pot.	50 k Ω lin. 6.2 W	180-009	
R51	carbon pot.	220 k Ω 5% 0.5 W	100-622	
R52	carbon pot.	220 k Ω 5% 0.5 W	100-622	
R53	carbon pot.	220 k Ω 5% 0.5 W	100-622	
R54A	carbon film	100 k Ω 5% 0.5 W	100-610	
R54B	carbon film	10 k Ω 5% 0.5 W	100-510	
R55	carbon film	68 k Ω 5% 0.5 W	100-568	
R56	carbon film	1.5 M Ω 5% 0.5 W	100-715	
R57	carbon film	47 k Ω 5% 0.5 W	100-547	
R58	carbon film	390 k Ω 5% 0.5 W	100-639	
R59	wire-wound	6.2 Ω 2 W	121-162	
R60	wire-wound	6.2 Ω 2W	121-162	
R61	carbon film	330 Ω 5% 0.5 W	100-333	

H6

	R62	carbon film	220 Ω 5% 0.5 W	100-322	
	R63	wire-w. pot.	200 Ω 1W	190-004	
	R64	carbon film	220 Ω 5% 0.5 W	100-322	
x	R65	wire-wound	13 Ω 2% 0.1 W	2916-A5	
	R66	carbon film	12 k Ω 5% 0.5 W	100-512	
	R67	carbon film	27 Ω 5% 0.5 W	100-227	10
	R68	metal film	90 k Ω 1% 0.5 W	140-354	10
	R69	metal film	10 k Ω 1% 0.5 W	140-089	10
	R70	carbon film	2.2 k Ω 5% 0.5 W	100-422	

SWITCHES

	Designation	Type	Code No.
x	S1	switch "GROUNDING SWITCH"	550-720
x	S2	switch "MULTIPLIER"	550-719
x	S3	switch "TEST VOLTAGE"	550-970
	S4	switch "CALIBRATE-CHARGE-MEASURE"	510-001
	S5	main switch	500-101

TRANSFORMER

	Designation	Type	Code No.
x	T1	power transformer, type 625 No.9899	770-520

LAMPS AND TUBES

	Designation	Type	Code No.
	V1	neon lamp Z10	400-803
	V2	tube EF86	300-036
	V3	tube EF184	300-068
	V4	tube 83A1	310-004
	V5	tube 150B2	310-009
	V6	tube EF86	300-036
	V7	tube EF86	300-036

H7

CABLE

Designation	Type	Code No.
W1	coaxial cable, 75 Ω , K19M, 0.41 m	600-005

VIBRATOR

Designation	Type	Code No.
x Z1	vibrator VR440	570-017

MISCELLANEOUS

	Type	Code No.
x	arrow knob, 36 mm	852-001
x	rubber foot	855-002

IM5S1

Designation	Type	Code No.
x M1	meter, 350 μ A, with scale	482-075

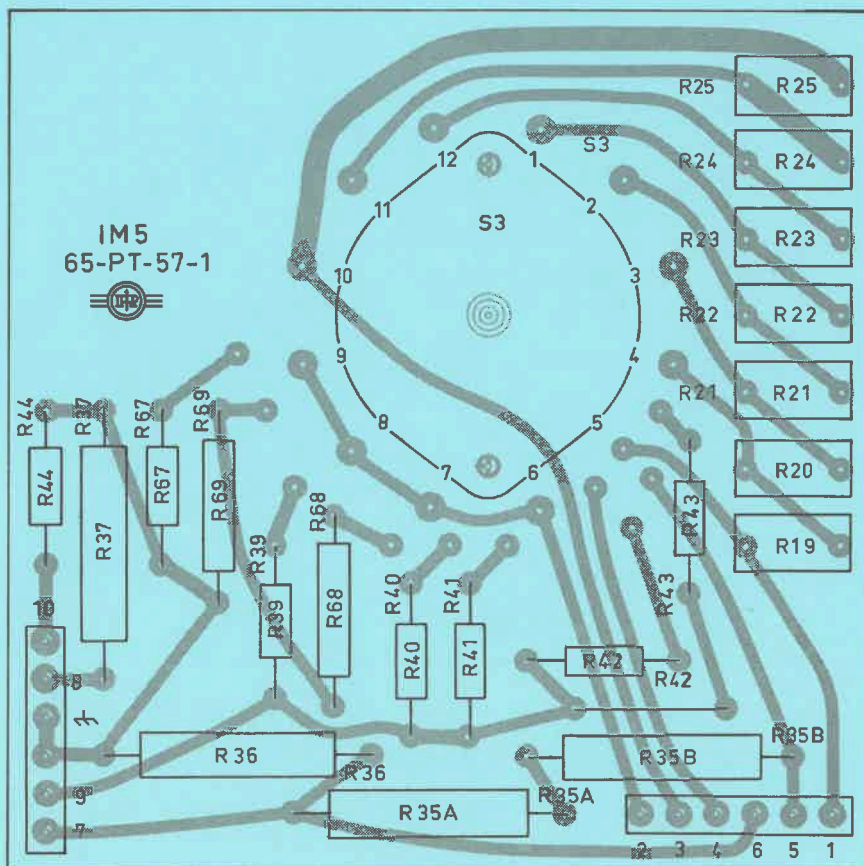
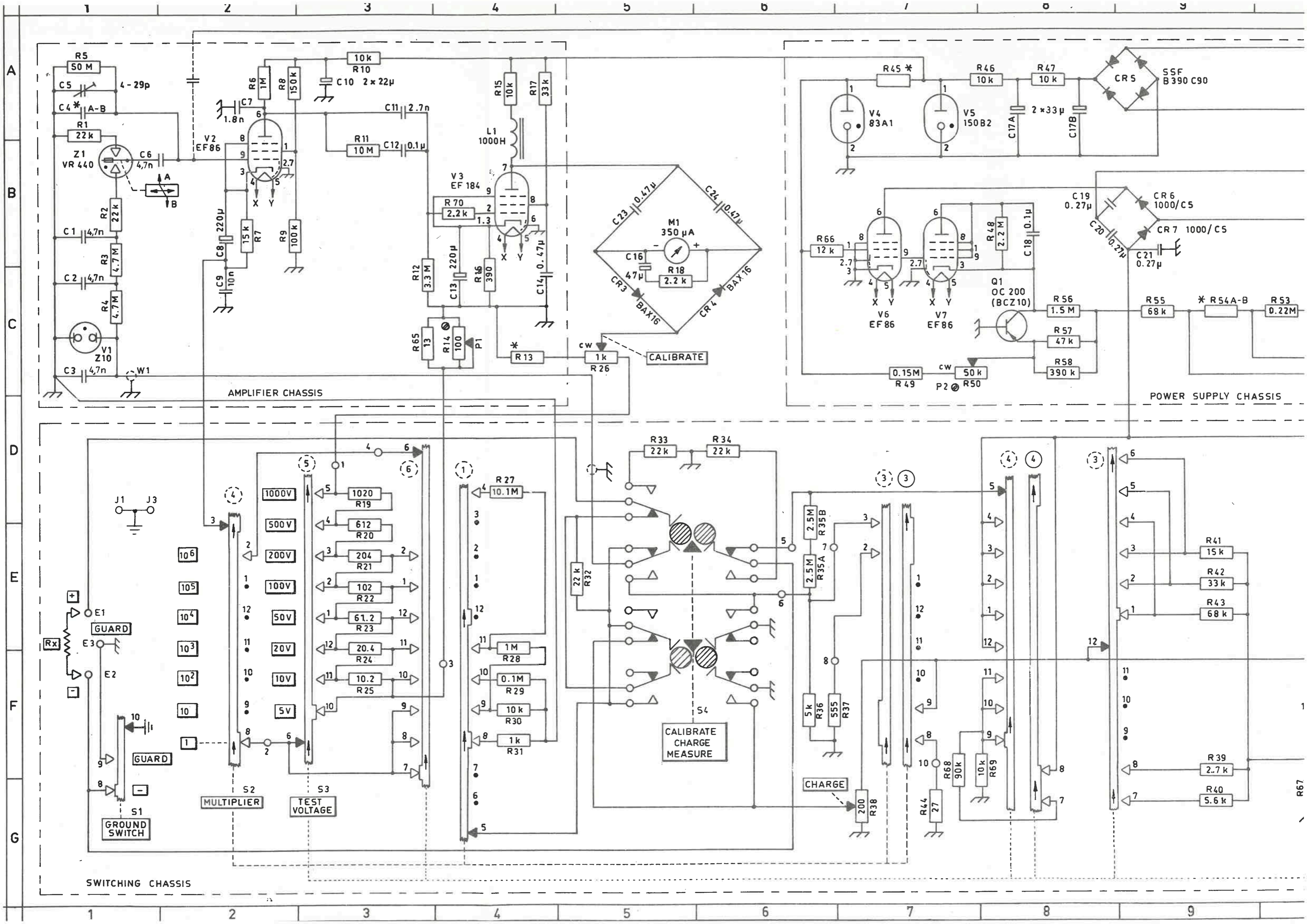
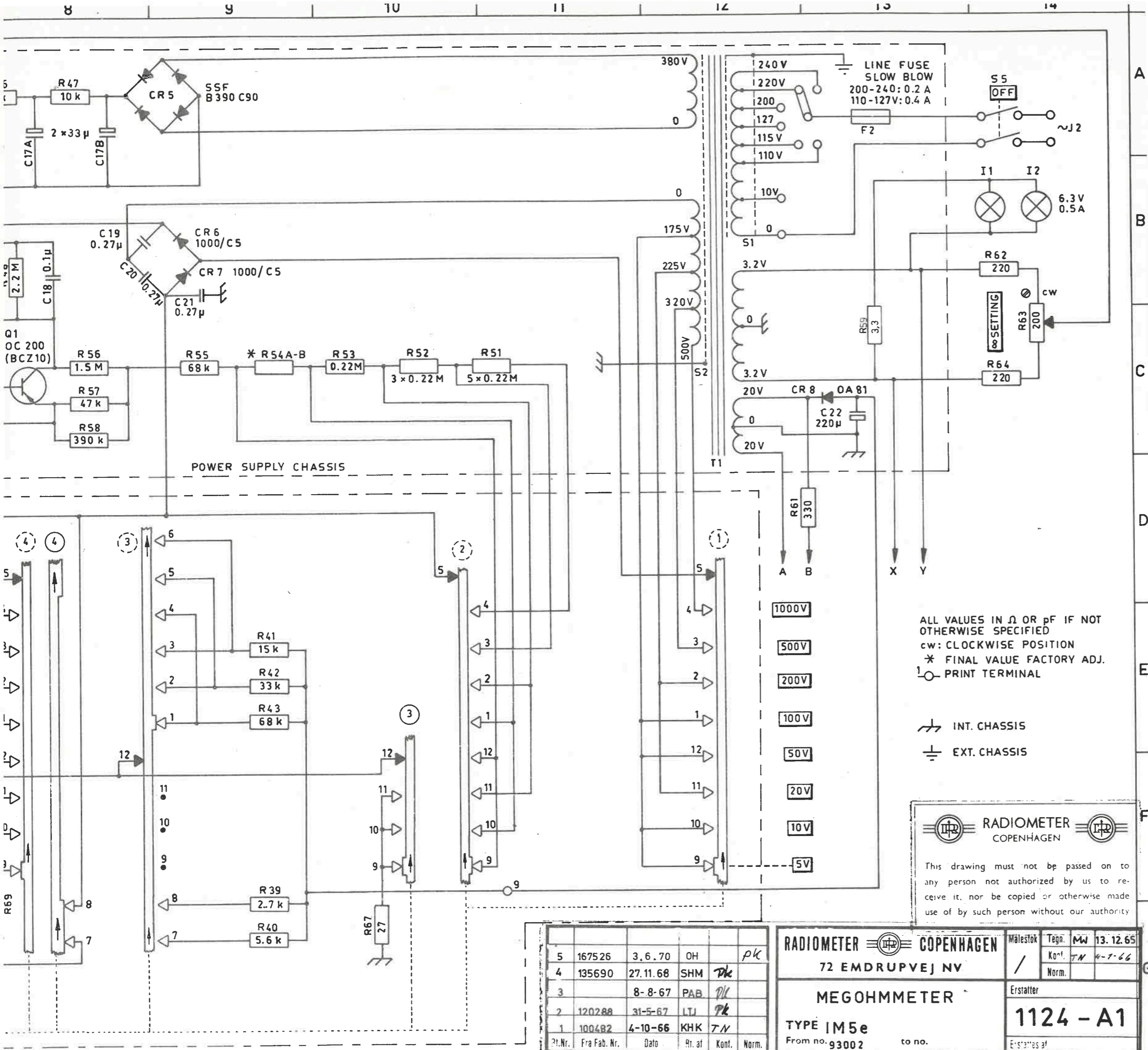

Fig.10.





Pt. Nr.	Fra Fab. Nr.	Dato	Rt. af	Kont.	Norm.
5	167526	3.6.70	OH		pk
4	135690	27.11.68	SHM	Dk	
3		8-8-67	PAB	Dk	
2	120288	31-5-67	LTJ	Dk	
1	100482	4-10-66	KHK	TN	

RADIOMETER COPENHAGEN
72 EMDRUPVEJ NV

MEGOHMMETER
TYPE IM5e
From no. 93002 to no.

Målestok: Tegn. MW 13.12.65
Kont. TN 4-7-66
Norm.

Erstatter
1124-A1
Erstatter af