

OPERATING INSTRUCTIONS



H.R.D.

TYPE 1605-A,-AH

# IMPEDANCE COMPARATOR

1605-A,-AH

G E N E R A L R A D I O C O M P A N Y



# GENERAL RADIO COMPANY

WEST CONCORD, MASSACHUSETTS 01781

617 369-4400

617 646-7400

## SALES ENGINEERING OFFICES

### NEW ENGLAND\*

22 Baker Avenue  
West Concord, Massachusetts 01781  
Telephone 617 646-0550

### METROPOLITAN NEW YORK\*

Broad Avenue at Linden  
Ridgefield, New Jersey 07657  
Telephone N.Y. 212 964-2722  
N.J. 201 943-3140

### SYRACUSE

Pickard Building  
East Molloy Road  
Syracuse, New York 13211  
Telephone 315 454-9323

### PHILADELPHIA

Fort Washington Industrial Park  
Fort Washington, Pennsylvania 19034  
Telephone 215 646-8030

### WASHINGTON\* and BALTIMORE

11420 Rockville Pike  
Rockville, Maryland 20852  
Telephone 301 946-1600

### ORLANDO

113 East Colonial Drive  
Orlando, Florida 32801  
Telephone 305 425-4671

### CHICAGO\*

6605 West North Avenue  
Oak Park, Illinois 60302  
Telephone 312 848-9400

### CLEVELAND

5579 Pearl Road  
Cleveland, Ohio 44129  
Telephone 216 886-0150

### LOS ANGELES\*

1000 North Seward Street  
Los Angeles, California 90038  
Telephone 213 469-6201

### SAN FRANCISCO

626 San Antonio Road  
Mountain View, California 94040  
Telephone 415 948-8233

### DALLAS\*

2600 Stemmons Freeway, Suite 210  
Dallas, Texas 75207  
Telephone 214 637-2240

### TORONTO\*

99 Floral Parkway  
Toronto 15, Ontario, Canada  
Telephone 416 247-2171

### MONTREAL

1255 Laird Boulevard  
Town of Mount Royal, Quebec, Canada  
Telephone 514 737-3673

\* Repair services are available at these offices.

General Radio Company (Overseas), 8008 Zurich, Switzerland  
General Radio Company (U.K.) Limited, Bourne End, Buckinghamshire, England  
Representatives in Principal Overseas Countries

# OPERATING INSTRUCTIONS

## TYPE 1605-A,-AH

# IMPEDANCE COMPARATOR

Form 1605-0100-H  
March, 1966  
ID 948

GENERAL RADIO COMPANY  
WEST CONCORD, MASSACHUSETTS, USA

Copyright 1956 by General Radio Company  
Concord, Massachusetts, USA



## TABLE OF CONTENTS

	Page
Section 1. INTRODUCTION . . . . .	1
1.1 Description . . . . .	1
1.2 Purpose . . . . .	1
1.3 Controls . . . . .	1
1.4 Connections . . . . .	2
1.5 Definitions and Abbreviations . . . . .	2
1.6 General Recommendations . . . . .	4
Section 2. PRINCIPLES OF OPERATION . . . . .	4
2.1 General . . . . .	4
2.2 Oscillator . . . . .	4
2.3 Bridge Equations . . . . .	5
2.4 Bridge Transformer . . . . .	5
2.5 Amplifier Input and Guard Circuit . . . . .	6
2.6 Signal Amplifier and Relay Circuit . . . . .	6
2.7 Phase-Sensitive Detectors . . . . .	7
Section 3. INSTALLATION . . . . .	7
3.1 Power Connections . . . . .	7
3.2 Grounding . . . . .	7
3.3 Mounting . . . . .	7
Section 4. OPERATING PROCEDURE . . . . .	8
4.1 General . . . . .	8
4.2 Connection of Standard and Unknown Impedances . . . . .	8
4.3 Frequency Selection . . . . .	8
4.4 Zeroing . . . . .	8
4.5 Calibration . . . . .	8
4.6 Range Selection . . . . .	8
4.7 Guard Circuit . . . . .	8
4.8 Measurement . . . . .	8
Section 5. RANGES AND ERRORS . . . . .	9
5.1 General . . . . .	9
5.2 Measurement of Low Impedance . . . . .	9
5.3 Measurement of High Impedance . . . . .	9
5.4 Correction for Large $\Delta Z$ Deviations on the 10% Range . . . . .	11
5.5 Possible Errors . . . . .	12
5.6 Extending the Deviation Ranges . . . . .	12
5.7 Unbalanced Loading on Transformer . . . . .	13
5.8 Measurements in Terms of R, L, or C Differences . . . . .	14
5.9 Measurement of $\Delta D$ and $\Delta Q$ . . . . .	15
Section 6. SPECIAL MEASUREMENTS . . . . .	16
6.1 Remote Measurements . . . . .	16
6.2 Direct or Transfer Impedance Measurements on Three-Terminal Networks . . . . .	16
6.3 Measurement of Transfer Voltage Ratios . . . . .	17
6.4 Measurements on Potentiometers . . . . .	18
6.5 Measurements on Small Capacitors . . . . .	19
6.6 Measurements on Ganged Capacitors . . . . .	20
6.7 Precise Measurement of Small-Dissipation-Factor Capacitors . . . . .	20
6.8 Measurement on Dielectric Samples . . . . .	21
6.9 Measurements on Balances Transformer Windings . . . . .	21
6.10 Measurements with Applied D-C Voltage and Current . . . . .	22
6.11 Use of External Recorders . . . . .	23
6.12 Automatic Sorting . . . . .	23
6.13 Connection of Shielded, Three-Terminal Capacitors . . . . .	23
6.14 Rapid Checking of Diode and Transistor Capacitance . . . . .	23
Section 7. SERVICE AND MAINTENANCE . . . . .	24
7.1 General . . . . .	24
7.2 Adjustments . . . . .	24
7.3 Adjustment Procedure . . . . .	25
7.4 Trouble-Shooting Procedure . . . . .	25
7.5 Trouble-Shooting Data . . . . .	28
PARTS LISTS AND SCHEMATICS . . . . .	30-43
APPENDIX A DIFFERENCE DATA-TYPE 1605-AH . . . . .	45



Figure 1.  
Panel View, Type 1605-A Impedance Comparator.



TYPE 1605-A IMPEDANCE COMPARATOR

# SPECIFICATIONS

**RANGES AND ACCURACY**

Type 1605-A: Measurement	Impedance Range	Impedance-Magnitude Difference	Phase-Angle Difference**	Accuracy	
Resistance or Impedance Magnitude	2Ω to 20 MΩ	±0.3%, ±1%, ±3%, ±10%, full scale. Can be adjusted for maximum of 50%.	±0.003, ±0.01, ±0.03, ±0.1, radian, full scale.	Difference readings accu- rate to within ±3% of full scale; i.e., for the ±0.3% impedance differ- ence scale, accuracy is 0.009% of the impedance being measured.	
Capacitance	40 pF* to 800 μF				
Inductance	20 μH to 10,000 H				
<b>Type 1605-AH:</b>					
Resistance or Impedance Magnitude	20Ω to 20 MΩ	±0.1%, ±0.3%, ±1%, ±3%, full scale. Can be adjusted for maximum of 15%.	±0.001, ±0.003, ±0.01, ±0.03 radian, full scale.		
Capacitance	40 pF to 80 μF				
Inductance	200 μH to 10,000 H				

\* To 0.1 pF with reduced accuracy.

\*\* Phase-angle difference is very nearly equal to D difference for capacitors and inductors, or to Q difference for resistors, as long as D or Q is less than 0.1.

**GENERAL**

**Test Frequency and Voltage:** Internal only, 100 c/s, 1 kc/s, 10 kc/s, 100 kc/s, all ±3%. Voltage across standard and unknown is approximately 0.3 V for TYPE 1605-A and 1 V for TYPE 1605-AH.  
**Power Required:** 105 to 125 or 210 to 250 V, 50 to 60 c/s, approximately 100 W. Operates satisfactorily on 400 c/s if line voltage is at least 115 V.

**Accessories Supplied:** TYPE CAP-22 Power Cord, telephone plug, external-meter plug, coaxial adaptor-plate assembly (fits panel terminals), spare fuses.

Models with other meter ranges and other frequencies are available on special order.

**MECHANICAL DATA Rack-Bench Cabinet**

Model	Width		Height		Depth		Net Weight		Shipping Weight	
	in	mm	in	mm	in	mm	lb	kg	lb	kg
Bench	19	485	7 ¼	185	13 ½	345	29 ½	13.5	37	17
Rack	19	485	7	180	12*	305	29 ½	13.5	37	17

\* Behind panel.

For a more detailed description, ask for General Radio Reprint E-103.

fuse 1.1 for 115V

1.00000  
 .00009  
 .00009  
 .00009  
 .01 %  
 .009 %  
 .001 %

# TYPE 1605-A IMPEDANCE COMPARATOR

SEE APPENDIX A FOR DIFFERENCE DATA ON TYPE 1605-AH.

## Section 1 INTRODUCTION

1.1 DESCRIPTION. The Type 1605-A Impedance Comparator (Figure 1) is designed to measure and indicate on meters the magnitude and phase-angle differences between two external impedances. No bridge-balancing operation is necessary, and these measurements may therefore be made rapidly and easily.

The instrument is basically a special, self-contained, bridge measurement system, consisting of a signal source, a bridge, and a detecting circuit. The bridge proper consists of the two external impedances to be compared and two highly precise unity ratio arms. Since these ratio arms are equal to within one part in  $10^6$ , the accuracy of impedance measurement depends largely on the precision of the external standard. The detector sensitivity permits measurements to 0.01% and 0.0001 radian, an order-of-magnitude more accurate than that of most precision impedance bridges.

In general, this bridge circuit is not adjusted for a balance, but instead the unbalance voltage is measured to give the required impedance difference information. The detector is phase sensitive, and selects those vector components of the unbalance voltage that are proportional to the impedance-magnitude difference in percent and the phase-angle difference.

The combination of four decade frequencies from 100 cps to 100 kc, with a very wide impedance range and several difference ranges, results in an instrument of wide versatility and flexibility.

1.2 PURPOSE. The combination of speed, wide range and high accuracy in the Impedance Comparator bring precision to rapid production testing and speed to delicate laboratory measurements. Obvious uses are the rapid sorting, matching, and se-

lecting of components. Inspection of the most precise components can be made rapidly over wide ranges of impedance and frequency. Components of poor phase angle (lossy capacitors or inductors, or resistors with a reactive component), which could cause circuit difficulties as easily as could components of improper value, can be rejected without the need for specialized test procedures.

The precision possible when precise impedance standards are used results in a system that can replace many intricate measurement setups in the laboratory and simplify the measurement procedure.

Because the impedance-difference information is provided continuously, the measurement of changes in impedance due to environmental changes is greatly simplified. With a suitable recorder, a record of the data may be easily made.

With an adjustable standard, the instrument may be brought to a null, in which case transfer impedances of three terminal networks may be determined. When the instrument is nulled, impedance shunting of the detector does not affect the balance, and the effect of impedance shunting the ratio arms is usually negligible due to the tight coupling of these arms.

Many other special measurements are possible, including checking the tracking of ganged components, adjusting balanced transformer windings, and loss measurements on dielectric materials. The process of comparison is basic to impedance measurement, and a precise comparator should find many other interesting uses.

1.3 CONTROLS. The following controls are on the panel of the Type 1605-A Impedance Comparator:

Name	Type	Function
PHASE ANGLE DIFFERENCE RADIANS	4-position selector switch	Selects deviation range to be read on PHASE ANGLE DIFFERENCE meter.
Function Switch	5-position selector switch	Selects type of operation.
IMPEDANCE DIFFERENCE PERCENT	4-position selector switch	Selects deviation range to be read on IMPEDANCE DIFFERENCE meter.
ZERO	Thumb-set buttons (2)	Zero meters.
FREQUENCY	4-position selector switch	Selects internal frequency.
CAL	Continuous rotary control	Calibrates instrument.
POWER	2-position toggle switch	Energizes instrument.



## GENERAL RADIO COMPANY

A panel view of the instrument is given in Figure 1 with the various controls and adjustments labeled. Figure 2 gives a detailed diagram of the bridge terminals.

The Type 1605-P1 Adaptor Plate (Figure 3) provides a means for directly plugging in components that have standard

$\frac{3}{4}$ -inch banana-plug terminals. On this unit, the common terminal is duplicated to provide a separate terminal for both standard and unknown impedances.

1.4 CONNECTIONS. The following connections are on the front and rear panels of the Type 1605-A Impedance Comparator:

Name	Type	Function	Ref Desig*
Common	Inner conductor of Type 874 Coaxial Connector (see Figure 2)	Detector input connection	J4
Guard	Outer conductor of Type 874 Coaxial Connector (see Figure 2)	Guard shield	J4
STANDARD	Jack-top binding post	Connector for standard	J2
UNKNOWN	Jack-top binding post	Connection for unknown	J1
Ground	Jack-top binding post	Chassis connection to ground	J3
Power	Three-terminal male connector	Line-voltage connection	PL501
CRO	Telephone jack	Oscilloscope connection for monitoring of signal	J5
—	Multipoint Jones connector*	Connection for meter voltages	S0401

\* See schematic diagram at rear of book.

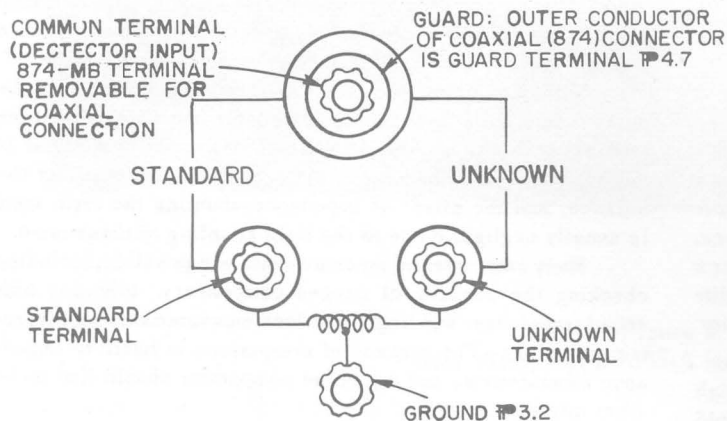

Figure 2.  
Diagram of Bridge Terminals.

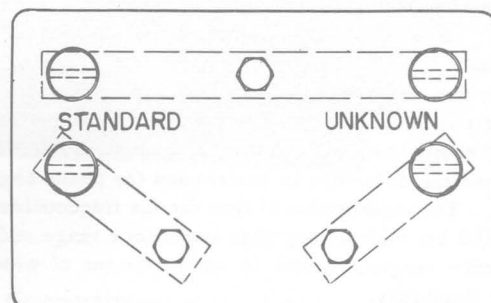

Figure 3.  
Type 1605-P1 Adaptor Plate.

### 1.5 DEFINITIONS AND ABBREVIATIONS.

a. A complex impedance may be written in polar or Cartesian form:

$$Z = |Z|e^{j\theta} = R + jX$$

where  $Z$  = complex impedance

$|Z|$  = magnitude of impedance

$\theta$  = phase angle of impedance

$R$  = Real part of impedance

$X$  = imaginary part of impedance or equivalent series reactance

Relationships between the two forms are:

$$|Z| = \sqrt{R^2 + X^2} \quad R = |Z| \cos \theta$$

$$\theta = \tan^{-1} X/R \quad X = |Z| \sin \theta$$

b. Likewise, a complex admittance can be written in two forms:

$$Y = |Y|e^{j\phi} = G + jB$$

where  $Y$  = complex admittance

$|Y|$  = magnitude of admittance

$\phi$  = phase angle of admittance

$G$  = real part of admittance or equivalent parallel conductance

$B$  = imaginary part of admittance or equivalent parallel susceptance

The relationships between the two forms become:

$$|Y| = \sqrt{G^2 + B^2} \quad G = |Y| \cos \phi$$

$$\phi = \tan^{-1} \frac{B}{G} \quad B = |Y| \sin \phi$$

TYPE 1605-A IMPEDANCE COMPARATOR

c. Relationships between the impedance and admittance are:

$$Y = \frac{1}{Z} \quad |Y|e^{j\phi} = \frac{1}{|Z|e^{j\theta}}; \quad |Y| = \frac{1}{|Z|}$$

$$\phi = -\theta \quad \frac{B}{G} = -\frac{X}{R}$$

d. The IMPEDANCE DIFFERENCE meter, which will be referred to as the  $\Delta Z$  meter, reads:

$$\frac{|Z_x| - |Z_s|}{\frac{|Z_x| + |Z_s|}{2}} = -\frac{|Y_x| - |Y_s|}{\frac{|Y_x| + |Y_s|}{2}}$$

where the subscripts x and s refer to the unknown and standard components. These expressions give the difference in impedance or admittance magnitude as a percent of the average of the magnitudes of the standard and unknown. If the percent difference is small, these expressions are equal to  $\frac{|Z_x| - |Z_s|}{|Z_s|}$  and  $-\frac{|Y_x| - |Y_s|}{|Y_s|}$  with negligible error. (Refer to paragraph 5.4 for the correction for large differences.)

These expressions will be referred to as  $\frac{\Delta|Z|}{|Z|}$  and  $\frac{\Delta|Y|}{|Y|}$  or, more simply,  $\Delta Z$  and  $\Delta Y$ .

A positive reading, therefore, indicates that the unknown is a larger impedance or a smaller admittance.

If pure elements are measured (R, L, or C), the  $\Delta Z$  indication can be interpreted as a percent difference in resistance or reactance. The reactance difference in percent is equal to the inductance or capacitance difference in percent. Note that if the standard and unknown impedances are interchanged, the capacitance difference will have the correct sign; that is, the plus reading will indicate that the unknown is the greater capacitance.

If the compared components are not pure, an error may result in interpreting the  $\Delta Z$  reading as a  $\Delta R$ ,  $\Delta L$ , or  $\Delta C$  if the angle of the standard or unknown is over 0.01 radian; that is, if D (for inductors or capacitors) or Q (for resistors) is greater than 0.01. (Refer to paragraph 5.8.)

e. The PHASE ANGLE meter, which will be referred to as the  $\Delta\theta$  meter, reads  $\theta_x - \theta_s = -(\phi_x - \phi_s)$  in radians.

The phase angle,  $\theta$ , is taken as positive in the counterclockwise direction on the complex impedance plane. (See Figure 4.) Therefore, a positive  $\Delta\theta$  indicates that the unknown

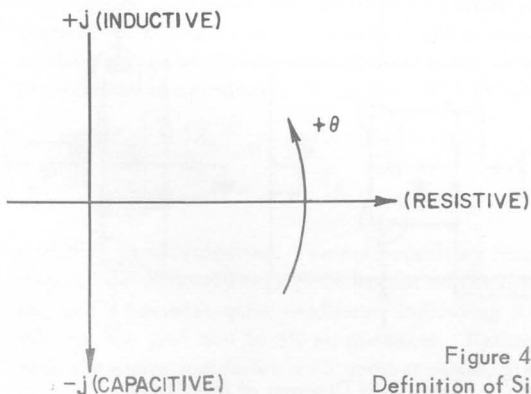

Figure 4. Definition of Sign of  $\theta$ .

is more inductive (or less capacitive) than the standard. Thus the reactance is positive if inductive ( $+j\omega L$ ) and negative if capacitive ( $-j\frac{1}{\omega C}$ ).

If relatively pure elements (C, R, or L) are measured (D or Q less than 0.1 or larger than 10),  $\Delta\theta$  can be interpreted as a D or Q difference with negligible error. The instrument indicates whichever quantity is less than 0.1.

f. For inductors and resistors, we will define

$$Q = \frac{X}{R} = -\frac{B}{G} \quad D = \frac{1}{Q} = \frac{R}{X} = -\frac{G}{B}$$

g. For capacitors, we will define

$$D = -\frac{R}{X} = \frac{G}{B}$$

(The minus sign is necessary to make the D of capacitor be positive since  $X_c$  is negative.)

h. Figure 5 defines D and Q in terms of series or parallel elements.

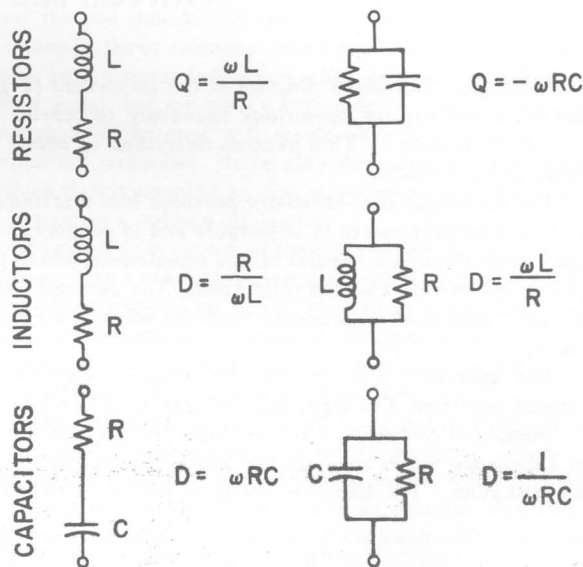

Figure 5. Definition of D and Q for Series and Parallel Elements.

i. The chart on page 15 and also on the rear cover should be of help in determining the correct sign for the various measurements for both the normal and reverse connections of the standard and unknown components. However, it is usually simple enough to determine the correct sign by remembering that:

- (1) A positive  $\Delta Z$  indicates that the component on the unknown terminals is the larger impedance.
- (2) A positive  $\Delta\theta$  indicates that the unknown has the larger phase angle where  $\theta$  is positive in the counterclockwise direction on the conventional complex Z plane.



1.6 GENERAL RECOMMENDATIONS. The general operation of this instrument is simple and straightforward. However, this instruction book does contain many graphs and charts, which are useful at the extremes of the various ranges and which are helpful in interpreting the meter indications. If the operation of the instrument is understood, reference to these charts is often unnecessary.

Measurement errors are most likely to result from either of two causes:

- a. The standard and unknown impedances are so large that the input impedance of the detecting circuit affects the measurement (refer to paragraph 5.3).
- b. A very small  $\Delta\theta$  is to be observed in the presence of a large  $\Delta Z$ , or vice versa (refer to paragraph 5.5).

Interpreting the meter indications can cause an error if:

- a. The  $\Delta Z$  indication is over 3% so that a correction is necessary (refer to paragraph 5.4).
- b. The meter indications are interpreted in other than polar form when  $\Delta\theta$  is large (refer to paragraphs 5.8 and 5.9).

One point should perhaps be emphasized. Occasionally, the bridge will give an indicator reading that may seem, intuitively, to be in error. Experience has shown that the bridge is correct. It is particularly important to know what is being measured and to make sure that the external components are connected properly. Most difficulties reported with similar instruments result from errors introduced by improper connection of the unknown component.

## Section 2 PRINCIPLES OF OPERATION

2.1 GENERAL. The block diagram of the instrument (Figure 6) indicates the various operations necessary to provide the two meter indications. This section describes in detail the circuitry in each block.

The stabilized R-C oscillator provides four test frequencies. The oscillator output is adjustable and is coupled to the bridge circuit through a special bridge transformer, which provides the inductively coupled ratio arms. The external "standard" and "unknown" components form the other two arms of the bridge.

The unbalance voltage from the bridge is amplified by the signal amplifier. The input stage of this amplifier is a special cathode-follower-type circuit which provides very high input impedance and a separate low impedance output for use as a guard point. The amplifier output is push-pull and is at-

tenuated with separate range switches to provide independent ranges on the two meters. Separate phase-sensitive detectors, using reference voltages derived from the bridge circuit, measure the components of the unbalance voltage that are in phase and in quadrature with the bridge voltage.

These two orthogonal voltages, which are measures of the magnitude and phase-angle differences, are fed to differential amplifiers, which drive the meters.

2.2 OSCILLATOR. A simplified schematic diagram of the oscillator is given in Figure 7. The circuit is a Wein-bridge-type R-C oscillator that uses a thermistor for amplitude control. The oscillator produces a push-pull output which feeds the push-pull cathode-follower output stage to drive the bridge transformer.

The capacitors  $C_a$  and  $C_b$  (Figure 7) are switched to change the frequency. The LEVEL adjustment is a factory adjustment to give the correct oscillator voltage. The panel CAL control is used to set the bridge voltage level to give a  $\Delta Z$  reading of 1% when a 1% unbalance calibration voltage is inserted.

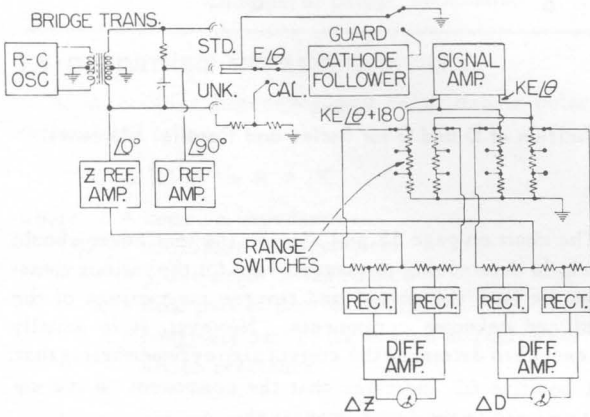

Figure 6.  
Block Diagram.

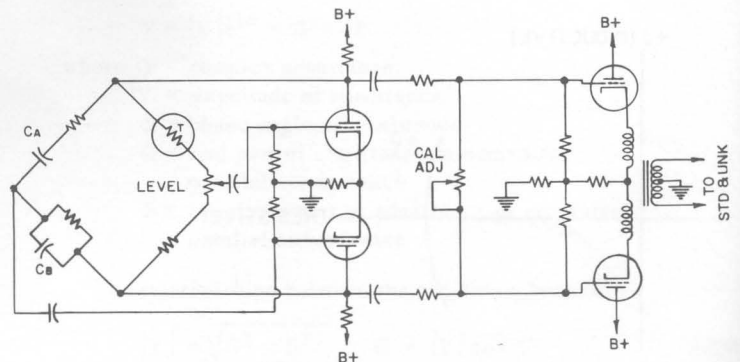

Figure 7. Simplified Diagram of Oscillator.

## TYPE 1605-A IMPEDANCE COMPARATOR

2.3 BRIDGE EQUATIONS. The basic bridge circuit is shown in Figure 8. If the voltages ( $E_{in}$ ) across the inductively coupled ratio arms are equal, the output voltage,  $E_o$ , is

$$\frac{E_o}{E_{in}} = \frac{Z_x - Z_s}{Z_x + Z_s}$$

The real part of this is,

$$\text{Re} \frac{E_o}{E_{in}} = \frac{\frac{|Z_x| - |Z_s|}{|Z_x| + |Z_s|}}{1 + \frac{\cos(\theta_x - \theta_s) - 1}{1 + \frac{|Z_x|}{2|Z_s|} + \frac{|Z_s|}{2|Z_x|}}}$$

If  $\theta_x - \theta_s$  is small,  $\cos(\theta_x - \theta_s)$  is close to unity and this equation reduces to

$$\text{Re} \frac{E_o}{E_{in}} \approx \frac{|Z_x| - |Z_s|}{|Z_x| + |Z_s|}$$

Within the range of the bridge ( $\theta_x - \theta_s \leq .1$ ), this approximation is extremely good, producing a maximum error of 0.25%. This is 0.25% of the actual impedance difference and is insignificant on all ranges. For example, in measuring impedance differences, on the 0.3% range, this error is less than 0.25% x 0.3% or 7.5 parts per million.

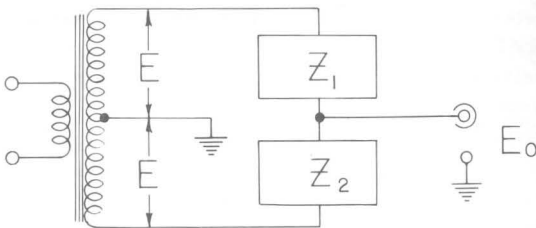

$$\frac{E_o}{E} = \frac{Z_1 - Z_2}{Z_1 + Z_2}$$

Figure 8. Basic Bridge Circuit.

Since it is generally desired to measure impedance difference as a percent of the standard rather than as a percent of the average of the standard and unknown, an additional approximation is necessary. If  $|Z_x| - |Z_s|$  is small

$$\frac{|Z_x| - |Z_s|}{|Z_x| + |Z_s|} \approx \frac{|Z_x| - |Z_s|}{2Z_s}$$

which is what is desired. The error resulting from this approximation is completely negligible except on the 10% range, where the scale becomes quite nonlinear, indicating 9.5% instead of 10% on one side and 10.5% on the other. Rather than complicate the meter indication with another scale, a simple correc-

tion can be applied or the zero shifted up to 0.5% (refer to paragraph 5.4).

The imaginary part of the bridge unbalance voltage is

$$\text{Im} \frac{E_o}{E_{in}} = \frac{\sin(\theta_x - \theta_s)}{\cos(\theta_x - \theta_s) + \frac{|Z_x|}{2|Z_s|} + \frac{|Z_s|}{2|Z_x|}}$$

If both  $\Delta Z$  and  $\Delta\theta$  are within the range of the bridge (10% and 0.1 radian), this expression reduces to:

$$\text{Im} \frac{E_o}{E} = \frac{1}{2}(\theta_x - \theta_s)$$

with an error of 0.25%, which is a percent of the meter indication and therefore negligible.

Therefore, as long as  $\Delta Z$  is less than 10%, and  $\Delta\theta$  less than 0.1 radian, these two orthogonal voltage components give the information desired with negligible error except for the non-linear  $\Delta Z$  scale when  $\Delta Z$  is over 3%.

2.4 BRIDGE TRANSFORMER. In the above calculations on the bridge output voltage, it was assumed that the voltage across the two transformer secondary windings was equal. A difference in these voltages would cause a corresponding difference in the meter indication. Not only must the two voltages be equal, but the source impedance of the windings must be matched, or an error will result when low-impedance components are measured. It is also desirable to have the two windings tightly coupled so that stray impedance shunting one will not cause a voltage unbalance.

Figure 9 is a sketch of the transformer showing its construction. It is a toroidal transformer with a high-permeability, wound-ribbon core. The inside winding is a modified banked winding, completely and symmetrically covering the core. Over this are two copper cups used for shielding to prevent unwanted electrostatic fields to the secondary.

The secondary windings are made by twisting together two identical wires and winding the twisted pair. This is a practical approximation to the ideal situation where the windings would occupy the same volume so that the flux linkage would be identical, producing unity coupling and equal output voltages.

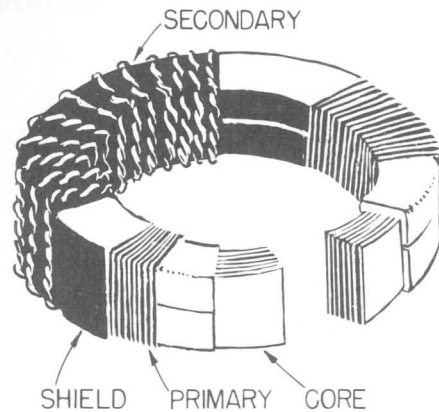

Figure 9. Bridge Transformer Construction.

This construction works very well. The open-circuit voltages are equal to within one part per million, the impedance difference (at 1 kc) is less than 50 microhms, and the coefficient of coupling is better than 0.9999. These quantities are such that 0.1  $\mu\text{f}$  placed across one winding at 1 kc will cause a negligible error. (Refer to paragraph 5.7.)

**2.5 AMPLIFIER INPUT AND GUARD CIRCUIT.** Figure 10 gives a simplified diagram of the block labeled cathode follower in Figure 6. This circuit was designed to have a number of features among which are high input impedance, constant gain, and two outputs, one of which, the guard output, is of low impedance.

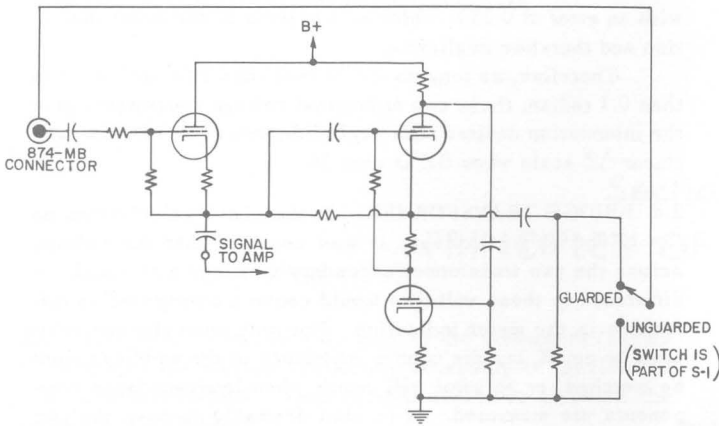

Figure 10.  
Simplified Diagram of Amplifier Input Circuit.

High input impedance is necessary for high-impedance measurements. (Refer to paragraph 5.3.) The guard output is used to reduce the input capacitance. This is especially useful for remote measurements where a shielded lead is desired to prevent pickup, but where the added input capacity, if the shield were grounded, would cause measurement errors. If the shield is tied to the guard, this capacity is reduced by a factor of 30. This action is similar to the well-known "Miller effect" except that in this case the gain is positive and approximately 0.97.

If no external shield is used, using the "guard" position will reduce the input capacity to less than 4  $\mu\mu\text{f}$ . If unguarded, the input capacity is about 9  $\mu\mu\text{f}$ . It is often convenient to switch from "guarded" to "unguarded" to see if stray capacity affects the measurement. For further consideration on the use of the guard, refer to paragraphs 4.7 and 6.1.

**2.6 SIGNAL AMPLIFIER AND RELAY CIRCUIT.** The signal amplifier (Figure 11) amplifies the signal and provides the push-pull outputs necessary for the phase-selecting circuits. Several adjustments keep the output voltages and impedances equal (refer to paragraph 7.2).

This amplifier drives the attenuators, which consist of two range switches. Any variations in gain in the amplifier are corrected by the internal calibration check since the calibration voltage is inserted before the amplifier.

The amplifier also contains a relay circuit used to open the meter circuits when the unbalance voltage is outside the range of the instrument. This circuit is included to protect the meters from repeated banging if one of the external components is disconnected. The relay can also be actuated by excessive hum if the external impedances are great (refer to paragraph 5.3). A jack is provided to permit the visual monitoring of this signal on an oscilloscope.

Figure 11.  
Simplified Diagram of Signal Amplifier and Relay Circuit.

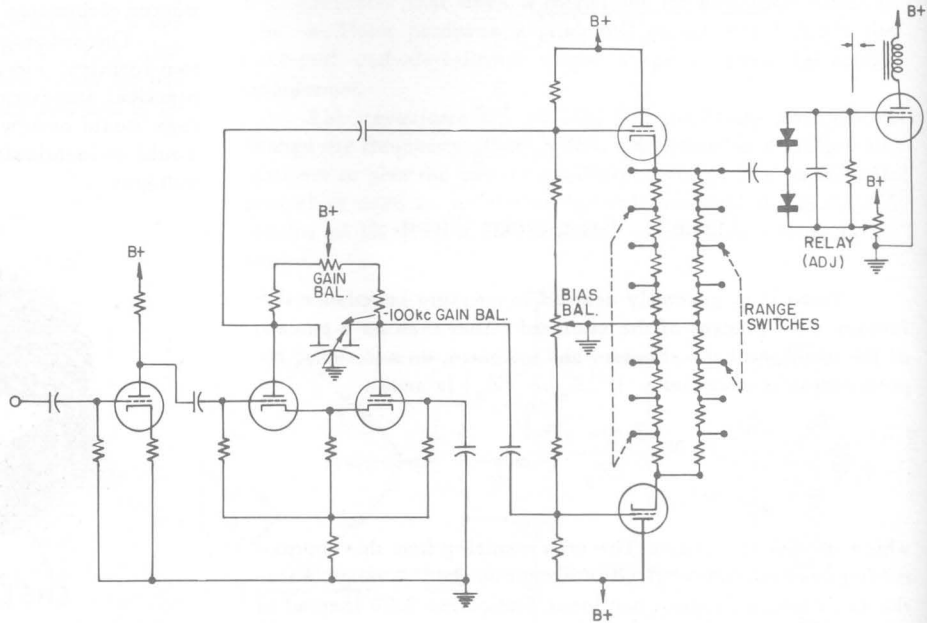



## TYPE 1605-A IMPEDANCE COMPARATOR

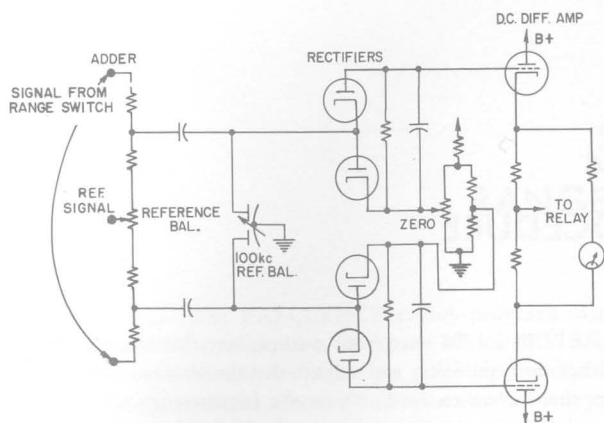

Figure 12.  
Simplified Diagram of Phase-Sensitive Detector.

**2.7 PHASE-SENSITIVE DETECTORS.** The method of phase selection used was chosen for its accuracy and stability, and is shown in Figure 12. The push-pull signal is added to and

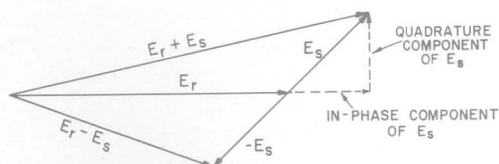

Figure 13.  
Operation of the Phase-Sensitive Detectors.

subtracted from a reference voltage of the desired phase, which is derived from the bridge input voltage and amplified in the reference amplifier. The difference in magnitude between the resulting sum and difference vectors (Figure 13) is very nearly equal to twice that component of the signal which is in phase with the reference, as long as the reference voltage is large compared to the signal. The sum and difference voltages are rectified and applied to the d-c meter amplifier.

Two such circuits are used, one for each meter, using one reference voltage in phase and the other in quadrature with the bridge input voltage.

## Section 3 INSTALLATION

**3.1 POWER CONNECTIONS.** Connect the instrument to a suitable power source (115 v or 230 v, 50-60 cps). Difficulty may be encountered when the 100-cycle test frequency is used if the power-line frequency is near 50 cycles, because of the harmonic relationship, particularly if the external components are of high impedance and unshielded, because of pickup on the amplifier input.

**3.2 GROUNDING.** For best results, particularly when the external impedances are high, the instrument, as well as nearby equipment, should be connected to a good ground. The ground terminal on the panel may be used for this connection.

**3.3 MOUNTING.** The instrument is available equipped for either bench or relay-rack mounting. For bench mounting (Type 1605-AM), aluminum end frames are supplied which attach to each end with two panel screws and four 10-32 round-head screws with notched washers (see Figure 1).

For rack mounting (Type 1605-AR), special brackets are supplied. These brackets permit either cabinet or instrument to be withdrawn independently.

To install the instrument in a relay rack:

a. Attach each mounting bracket (A) to the rack with two 12-24 round-head screws (B). Use the inside holes on the brackets.

b. Slide the instrument onto the brackets as far as it will go.

c. Insert the four knurled panel screws with attached washers (C) through the panel and the bracket and thread them into the rack. The washers are provided to protect the face of the instrument.

d. At the rear of the instrument, remove the two round-head screws that hold the cabinet.

e. In the rear of each side wall of the cabinet install screw (D) with clearance for the slot in the bracket.

To remove the instrument, remove only the four panel screws (C) and draw the instrument forward out of the rack. To remove the cabinet and leave the instrument mounted, release the two screws (D) and pull the cabinet back.

The instrument may be mounted in any position, provided it is not subjected to undue shock or vibration. Do not block cabinet air holes since the instrument could overheat if air circulation is impeded.

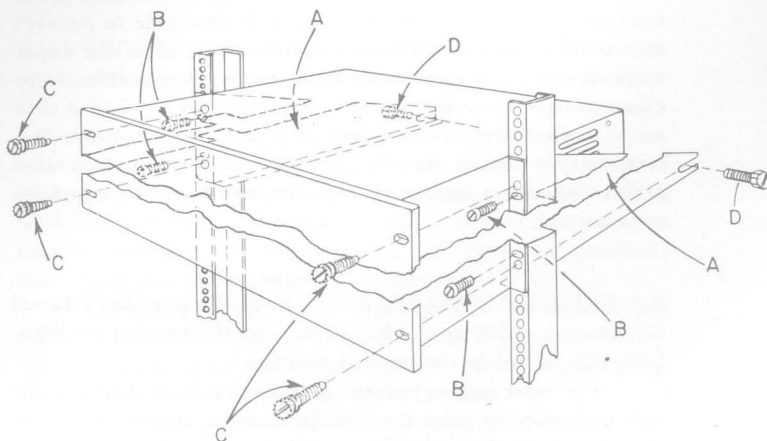

Installation of relay-rack model Type 1605-AR.

## Section 4

# OPERATING PROCEDURE

**4.1 GENERAL.** This operating procedure is the general procedure for comparing components which are well within the ranges of the instrument. For special measurements, and for measurements of impedances at the extremes of the range, refer also to Sections 5 and 6.

Install the bridge as described in Section 3, and turn the POWER switch on. Allow time for sufficient warmup. When the instrument is first turned on, the meters will move off-scale. After a minute or so, they should come to rest near zero (midscale) if the function switch is set to zero. Although measurements can be made as soon as the bridge is operative, it is desirable to wait a few minutes to stabilize the oscillator and meter circuits. After 15 minutes, the meter drift should be very small so that only occasional rechecking of the zero is necessary except for the most precise measurements.

**4.2 CONNECTION OF STANDARD AND UNKNOWN IMPEDANCES.** Because so many different types of components may be measured, it was impossible to design a suitable terminal arrangement for all measurements. The terminals on the instrument itself were designed to have small capacity. For measurements unaffected by a moderate amount of input capacity, connections may be simplified by means of the Type 1605-P1 Adaptor Plate, especially if the components have banana-plug terminals on  $\frac{3}{4}$ -inch spacing.

When low-impedance measurements are made, it is necessary to make sure the connections have negligible resistance. In some cases, it is desirable not to use the Type 1605-P1 Adaptor Plate due to the possible impedance of the banana-plug contact.

For high-impedance measurements, it is desirable not to add any capacitance to ground from the common terminal (refer to paragraph 5.3). If the unknown is encased and the case is connected to one terminal, it is desirable to connect this terminal to a transformer terminal. Note also that capacity between leads connecting external components effectively changes the value of these components.

In some applications, special jigs will be required. Remember that such a jig will be in the bridge circuit so that series impedance and stray capacitance should be carefully considered.

**4.3 FREQUENCY SELECTION.** The bridge provides internal frequencies of 100 cps, 1 kc, 10 kc, and 100 kc. Set the FREQUENCY switch to the desired position.

For most measurements, it is desirable to consider the test frequency in order that the information presented will be useful and so that the high-impedance limitation is not exceeded (refer to paragraph 5.3).

**4.4 ZEROING.** To zero both meters, set the function switch to either zero position and adjust the thumb zero adjustments to set the meters to zero. Once the instrument is warmed up, it should not be necessary to check the meter zero except for the most precise measurements. The drift should be less than 5% of full scale for at least a day.

As the frequency or range control settings are changed, the zeros should move less than one division or 3% of full scale, so that rezeroing is usually not necessary.

**4.5 CALIBRATION.** To calibrate the instrument, set the IMPEDANCE DIFFERENCE PERCENT switch to 1 and the function switch to CAL 1%. Adjust the CAL control to give the 1% (full scale) indication. Ignore the  $\Delta\theta$  reading.

For most accurate measurements, the calibration should be rechecked if the test frequency is changed. The calibration level should be constant to about 5% as the frequency is changed so that resetting is usually not necessary.

When low impedances (below 20 ohms) are being measured, it is desirable to set the calibration level with the external components connected (refer also to paragraph 5.2).

**4.6 RANGE SELECTION.** The desired deviation ranges are set by the IMPEDANCE DIFFERENCE PERCENT and PHASE ANGLE DIFFERENCE RADIANS switches. These switches indicate the full-scale value of the meters.

Note that on the 10%  $\Delta Z$  range, a correction is necessary if percent with respect to the standard is desired (refer to paragraph 5.4). Note also that there is a possibility of error in measurement on the most sensitive range, if the other meter is indicating on its least sensitive range (refer to paragraph 5.5).

**4.7 GUARD CIRCUIT.** The OPERATE GUARDED and OPERATE UNGUARDED positions of the function switch are the same except for the potential of the outer conductor of the Type 874 Coaxial Connector. When the switch is at OPERATE UNGUARDED, this outer conductor is grounded. With the switch at OPERATE GUARDED, the outer conductor is driven at nearly the same potential as the inner conductor (detector input) and therefore acts as a guard circuit. This results in the input capacity being substantially lower in the OPERATE GUARDED position. (Refer to paragraph 2.5.)

In the measurement of high Q inductors there is a possibility of oscillation when the OPERATE GUARDED position is used, which will actuate the OFFSCALE relay. The OPERATE UNGUARDED position should be used if such oscillations occur.

**4.8 MEASUREMENT.** With the instrument zeroed and calibrated, and the components in place, the meters will indicate the desired quantities when the function switch is set to either the OPERATE GUARDED or OPERATE UNGUARDED position.

## Section 5

### RANGES AND ERRORS

5.1 GENERAL. The FREQUENCY switch provides four test frequencies of 100 cycles, 1 kc, 10 kc, and 100 kc. It is not possible to use an external oscillator for other frequencies since the phase-shift networks also depend upon the frequency. The fixed condensers of the oscillator and phase-shift network could be changed to produce other fixed frequencies, but this is a rather complicated procedure.

The deviation ranges provided are 0.3, 1, 3, and 10% full-scale for  $\Delta Z$ , and 0.1, 0.03, 0.01, and 0.003 radian full-scale for  $\Delta\theta$ . Wider ranges are possible by calibration at lower oscillator levels (refer to paragraph 5.6).

The impedance range is quite wide. The range limitations are simple at the low end (refer to paragraph 5.2), but become more complex at the high end (refer to paragraph 5.3).

The choice of several test frequencies permits wide ranges of C and L. All these ranges are not possible at one particular frequency.

Paragraph 5.5 lists the possible errors that may occur in measurement. These errors are negligible compared with the over-all 3% accuracy for most measurements.

#### 5.2 MEASUREMENT OF LOW IMPEDANCES.

5.2.1 NORMAL LIMITS. The low end of the impedance range is limited by the power available from the transformer and the source impedance of the primary circuit. The ranges for R, L, and C values of external components are as follows:

	R	L	C
100 cps	2 $\Omega$	5 mh	800 $\mu$ f
1 kc	2 $\Omega$	500 $\mu$ h	80 $\mu$ f
10 kc	2 $\Omega$	50 $\mu$ h	8 $\mu$ f
100 kc	8 $\Omega$	20 $\mu$ h	0.2 $\mu$ f

If the unknown components are of substantially lower impedance than these values, it will be impossible to obtain sufficient bridge voltage to calibrate the instrument.

As these values are approached, bridge voltage will be slightly reduced when the components are connected, so that the calibration should be made with the components in place. At 100 kc, the bridge voltage may actually increase with a large capacitive load due to resonance with the transformer inductance. Also as these values are approached, there may be an increase in the error at opposite deviation extremes due to distortion resulting from the oscillator loading (refer to paragraph 5.5).

It is, of course, necessary to make low-impedance connections to the unknown in order to avoid errors. The connections should be made directly to the panel terminals if small deviations are to be detected. The smallest resistance difference that the instrument can detect is  $0.01\% \times 2\Omega = 200\mu\text{ohms}$ . The difference in output impedance between the two secondary

windings is substantially lower than this so that it causes negligible error.

5.2.2 EXTENDING THE LOW-IMPEDANCE RANGE. Two general methods of extending the range to lower impedances are useful. The first and simplest method reduces the bridge voltage to reduce the power necessary in the unknown components. The procedure is simply to calibrate down a scale, that is, adjust the CAL ADJ control to read full scale (10) with the IMPEDANCE DIFFERENCE switch set at 0.3%, whereupon the 0.3% scale becomes a 1% scale, the 1% scale becomes a 3% scale and so forth. The  $\Delta\theta$  scales are shifted in the same manner. The calibration should be made with the standard and unknown components in place. With this method, the low impedance limit is extended to approximately  $\frac{1}{2}$  ohm. The smallest deviation that can be detected is therefore  $0.03\% \times 0.5\Omega = 150\mu\text{ohms}$ .

This method can be extended to lower values by calibration at even lower levels, but the setting of the calibrator voltage will become less accurate if set to a fraction of full scale.

The second method is to put equal impedances (R) in series with both the standard and unknown so that the total impedance is above the limit. With this method, both the  $\Delta Z$  and  $\Delta\theta$  readings must be corrected.

$$\frac{R_x - R_s}{R + \frac{R_x + R_s}{2}} \times \frac{R + \frac{R_x + R_s}{2}}{\frac{R_x + R_s}{2}} = \frac{R_x - R_s}{\frac{R_x + R_s}{2}}$$

Reading                      Correction                      Desired

As an example, the correction for measuring resistance difference is given above. The resistors (R) need not be equal since it is possible to determine the difference and correct for it.

5.3 MEASUREMENT OF HIGH IMPEDANCES. With instruments of this type, where the bridge output is measured rather than brought to a balance, the high end of the impedance range is limited by the input impedance of the detecting or measuring circuit. In this instrument, the input circuit was designed with this in mind. With the function switch in the OPERATE GUARDED position, the input impedance is less than  $4\mu\mu\text{f}$  in parallel with over 200 megohms. In the "grounded" position, the capacitance is increased to approximately  $9\mu\mu\text{f}$ .

The effect of this finite impedance is to attenuate the signal and shift its phase. This effect can be easily seen by the equivalent circuit of Figure 14. For some applications, the equivalent circuit of Figure 15 is useful.

The effect of the attenuation is easy to calculate. For example, if the input resistance is 200 megohms (at such a



# TYPE 1605-A IMPEDANCE COMPARATOR

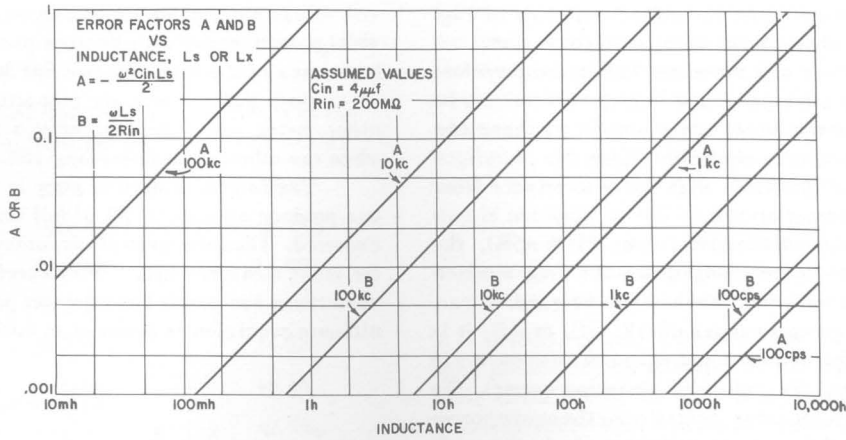

Figure 18. Factors A and B vs Inductance.

The A term is simply the magnitude correction and causes a percent error, so that it is negligible if less than 0.02 (2%). The B term is the effect of phase shift, and results in an additive error so that its effect is worst on the most sensitive ranges.

The values of A and B are plotted in Figures 16, 17, and 18 for different types of components (R, C, and L) at different frequencies with a nominal input impedance of 4 µµf in parallel with 200 megohms.

The error terms involving B above also include the reading of the other meter. This means that to find the  $\Delta Z$  error, one has to know  $\Delta\theta_A$  as well as B. It is easy enough to calculate  $B\Delta Z_A$  or  $B\Delta\theta_A$ , or the chart of Figure 19 can be used to avoid mistakes.

Example 1. Say it is desired to compare the phase shifts of resistors at 100 kc to  $\pm 0.001$  radian  $\pm 1\%$  accuracy when the resistors may differ by 1%. How large may the resistors be?

From Figure 16, we see that the percent error, A, will be 0.01 (1%) at 4 megohms. However, the phase-shift error will be more important at this high frequency. From Figure 19, we see that for a  $\Delta Z$  of 1% and an allowable  $\Delta\theta$  error of 0.001, B must be below 0.1. From Figure 16, we see that the resistors must be below 80 kilohms.

Example 2. Say we want to compare the magnitude of two condensers of 1000 µµf (refer to paragraph 5.8 for the capacitance difference) at 100 cycles to 0.01%. What is the allowable  $\Delta\theta$  (or  $\Delta B$ )?

The attenuation error (Figure 17) is negligible. From Figure 17, B is 0.004 at 100 cycles for 1000 µµf. From Figure 19, the allowable  $\Delta\theta$  is therefore 0.025.

These charts are designed primarily to show the range possible rather than to attempt to make corrections for measurements outside the range. Crude corrections are possible, but precision is difficult due to the added input impedance resulting from the actual physical connection of the components, which is hard to determine.

Hum pickup can also cause appreciable difficulty when high-impedance (at 60 cycles) components are measured. A slight amount of hum pickup should cause no error in the readings except for a beating vibration when the 100-cycle test frequency is used. Large hum pickups, however, may cause the off-scale indicator to be actuated, which opens the meter circuits. A jack at the rear of the instrument permits monitoring of the signal to determine whether the off-scale indicator has been actuated by hum or by a large unbalance signal.

Usually this pickup difficulty can be overcome by proper shielding of the components under test. Grounding the instrument is usually necessary, as well as grounding any nearby equipment.

5.4 CORRECTIONS FOR LARGE  $\Delta Z$  DEVIATIONS ON THE 10% RANGE. When the instrument is used on the 10%  $\Delta Z$  range, the approximation in going from

$$\frac{|Z_x| - |Z_s|}{|Z_x| + |Z_s|} \text{ to } \frac{|Z_x| - |Z_s|}{|Z_s|}$$

results in an error that reaches 0.5% (5% of full scale) as  $\Delta Z$  approaches 10%. At a 5% deviation, this error is only 0.13% (1.3% of full scale), which is less than the general accuracy statement of 3%, so that the correction can generally be neglected.

This correction can be made in two ways, depending on whether readings are to be made or whether a limit is set.

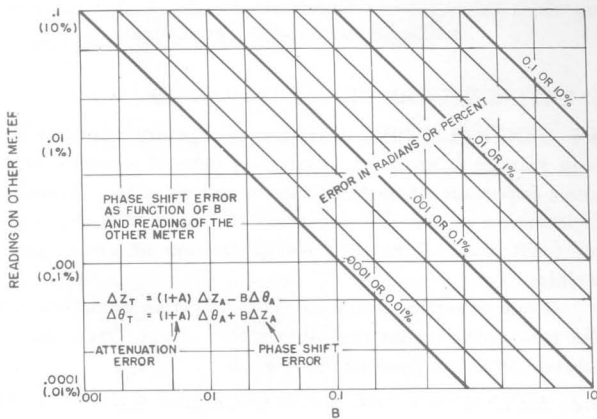

Figure 19.

Phase Angle Error as a Function of B and  $\Delta Z$  Range or Magnitude Error as a Function of B and  $\Delta\theta$ .

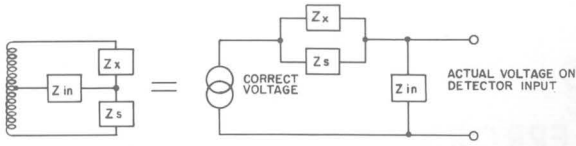

Figure 14.

Equivalent Circuit of Bridge Circuit Loaded by Input Impedance of Detector.

frequency that the capacitance was negligible), there would be an error of approximately 10% when 40-megohm resistors are measured.

The effect of the phase shift is more difficult to correct for since it is a function of the frequency, the external impedance, and both meter readings. It is easy to see what happens, however. An unbalance voltage that was real (magnitude only), for example, would be shifted in phase, resulting in a  $\Delta\theta$  meter reading.

The charts of Figures 16 to 19 are given to show quickly the limitations for measuring various components at the various frequencies. A little algebra is necessary to show their use.

With an input admittance,  $Y_{in}$ , the actual bridge voltage is proportional to:

$$-2 \frac{Y_x - Y_s}{Y_x + Y_s + Y_{in}}$$

For the correct reading, a correction factor is necessary:

$$-2 \frac{Y_x - Y_s}{Y_x + Y_s + Y_{in}} \times \frac{Y_x + Y_s + Y_{in}}{Y_x + Y_s}$$

$$= -\frac{Y_x - Y_s}{Y_x + Y_s} = \frac{Z_x - Z_s}{Z_x + Z_s}$$

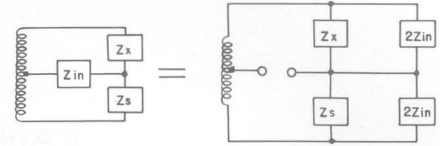

Figure 15.

Alternate Equivalent Circuit of Loaded Bridge Circuit.

If we let this correction factor be:

$$\frac{Y_x + Y_s + Y_{in}}{Y_x + Y_s} = 1 + \frac{Y_{in}}{Y_x + Y_s} = 1 + A + jB$$

$$\text{where } A = \text{Re} \frac{Y_{in}}{Y_s + Y_x}$$

$$B = \text{Im} \frac{Y_{in}}{Y_s + Y_x}$$

or since:  $Y_s \approx Y_x$

$$A \approx \text{Re} \frac{Y_{in}}{2Y_s}$$

$$B \approx \text{Im} \frac{Y_{in}}{2Y_s}$$

we can write:

$$\Delta Z_T = \Delta Z_A (1 + A) - B \Delta \theta_A$$

$$\Delta \theta_T = \Delta \theta_A (1 + A) + B \Delta Z_A$$

where the subscript T refers to the true value and A to the actual value read on the meters; also  $\Delta\theta$  and  $\Delta Z$  are expressed as decimals (i.e. 1% = 0.01).

Note that A and B may be positive or negative (refer to formulas in Figures 16, 17, and 18).

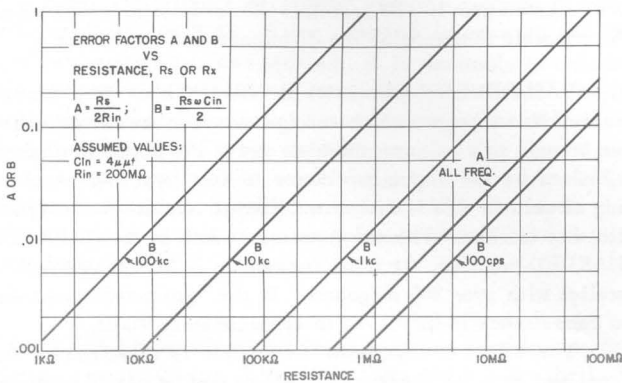

Figure 16.  
Factors A and B vs Resistance.

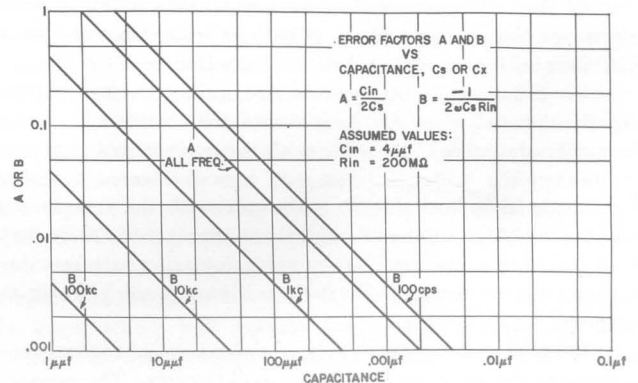

Figure 17.  
Factors A and B vs Capacitance.

If readings are to be made, the correction chart of Figure 20 is useful. This chart shows no difference at zero.

If a tolerance is set and the meter indication therefore need be correct at only  $\pm$ one particular value, the zero may be offset in order to make the meter scale correct at these two points. The zero correction is shown in Figure 21.

Figure 22 gives a 10% scale with the zero offset. Note that the readings are correct at  $\pm 10$ .

If the limits are nonsymmetrical (i.e. +10% -5%), the value of the standard could be changed to make them symmetrical so that the simple zero shift method can be used.

When limits are given in terms of  $\Delta Y$ ,  $\Delta C$ , or  $\Delta G$ , it is useful to interchange the standard and unknown components in order to keep the sign of the indicated deviation correct. To set the limits correctly for large deviations, the above procedure can be used with the zero corrections made in the positive direction as indicated above. If the standard and unknown are not interchanged, the zero correction should be negative, but of the same amount, and the  $\Delta Z$  meter will read

$$- \frac{|Y_x| - |Y_s|}{|Y_s|} \times 100\%$$

**5.5 POSSIBLE ERRORS.** Within the deviation ranges of the instrument (10% and 0.1 radian), the basic bridge equations (paragraph 2.3) give the desired magnitude difference and phase-angle difference with negligible error, except for the scale correction necessary when  $\Delta Z$  is large (paragraph 5.4). This information, presented in polar form, can be interpreted in terms of  $\Delta R$ ,  $\Delta L$ , or  $\Delta C$  and  $\Delta D$  and  $\Delta Q$  for many measurements (refer to paragraphs 5.8 and 5.9).

This bridge output voltage, of course, may be in error if the impedance range is exceeded, so that it is important to make sure the standard and unknown components are within the range (refer to paragraphs 5.2 and 5.3).

The instrument may produce small errors above the specified 3% when the meters are used at opposite range extremes; that is, when one meter is near full scale on its least-sensitive range and the other reading on its most-sensitive range. The error occurs on the more sensitive meter.

These errors result from several causes. Under the above conditions, the vector-adding operation of the phase-sensitive detector of the sensitive meter causes a slight error because the signal voltage, which is largely in quadrature with the reference voltage, becomes large. In the worst case, when the coarse meter is indicating 10% or 0.1 radian, the reading on the sensitive meter is reduced by less than 5% of its value, which is 0.015% (0.00015 radian) in the worst case.

Under the same conditions of opposite range extremes, a small error in the phase of the quadrature voltage causes some of the large quadrature voltage to appear in phase with the reference. This phase-shift error in the reference voltage could be caused by a change value of the components of the oscillator or phase-shift network. The  $\Delta Z$  reference is less susceptible to this error, since the phase shift is small. The  $\Delta \theta$  reference shift is minimized because of the like resistors and condensers in the oscillator and phase-shift network, which cause the effects of temperature to cancel to some degree.

Likewise, changes in harmonic distortion in the signal voltage will cause an effective phase-shift change since the harmonics of the reference are not at the correct phase.

Both these errors are proportional to the reading of the other meter and should be only a few percent of full scale when the other meter is reading 10% or 0.1 radian.

The largest source of error is the 1% meter itself. This can produce an error of 2% of full scale since the meter is zero centered. Thus the over-all accuracy is about 3% of full scale for most measurements. With careful zeroing, measurements about zero can easily have greater precision so that the actual ultimate precision is better than 0.01% (0.0001 radian).

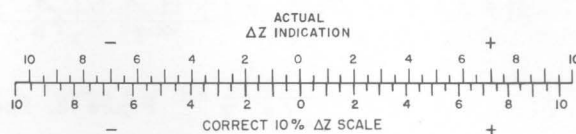

Figure 20. Correction Chart for 10%  $\Delta Z$  Range.

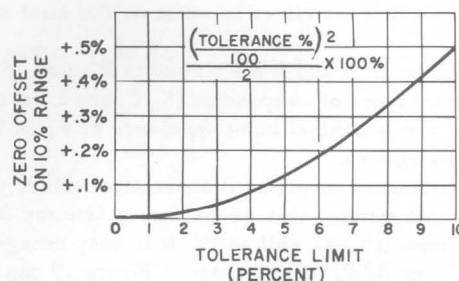

Figure 21. Zero Offset for Correct Reading at Tolerance Limit.

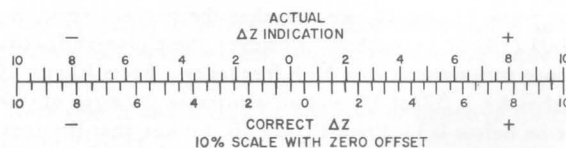

Figure 22.  $\pm 10\%$   $\Delta Z$  Scale with Zero Offset.

**5.6 EXTENDING THE DEVIATION RANGES.**

**5.6.1 GENERAL.** Wider deviation ranges are possible if the bridge voltage is reduced. However, several sources of error become important when these ranges are extended. If only the  $\Delta Z$  deviation or the  $\Delta \theta$  deviation is larger than the nominal limit (10% and 0.1 radian), simple means of correction are possible.

If one deviation range is extended, it is desirable not to make measurements on the other meter, since large and complicated corrections are necessary.

**5.6.2 EXTENDING THE  $\Delta Z$  RANGE ( $\Delta \theta \leq 0.1$  RADIAN).** Wider deviation ranges are possible by adjustment of CAL ADJ to give a  $\Delta Z$  reading lower than 1%. It is also necessary to offset the zero in order to center the range on the meter. This zero offset should be made after calibration.



## TYPE 1605-A IMPEDANCE COMPARATOR

The following table gives the necessary calibrating and zeroing data. For these settings, the desired tolerance limit will always be a reading of  $\pm 10\%$  on the  $\Delta Z$  meter.

Desired Tolerance Limit	CAL (on the 1% or 0.3% range)	ZERO (on the $\pm 10\%$ scale)
$\pm 10\%$	1.0%	+0.5%
$\pm 15\%$	0.66%	+0.75%
$\pm 20\%$	0.495%	+1.0%
$\pm 25\%$	0.394%	+1.25%
$\pm 30\%$	0.326%	+1.5%
$\pm 40\%$	0.240%	+2.0%
$\pm 50\%$	0.188%	+2.5%

Figures 23 and 24 give the actual calibration for 20% and 50% limits. The settings are made as in the table above.

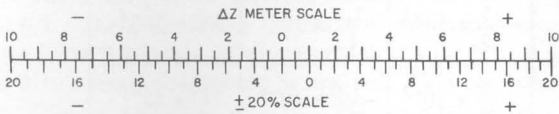

Figure 23.  $\pm 20\%$   $\Delta Z$  Scale.

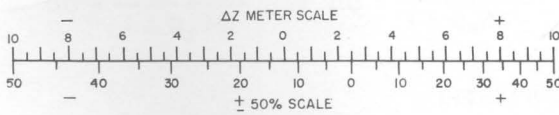

Figure 24.  $\pm 50\%$   $\Delta Z$  Scale.

5.6.3 EXTENDING THE  $\Delta\theta$  RANGE ( $\Delta Z \leq 10\%$ ). If  $\Delta Z$  is small ( $\leq 10\%$ ), the  $\Delta\theta$  meter will read  $\frac{\sin\Delta\theta}{1 + \cos\Delta\theta}$  with negligible error. This expression is proportional to  $\Delta\theta$  in radians if  $\Delta\theta$  is small, and is valid with an error of only 1.3% up to  $\Delta\theta$  values of  $\Delta\theta = 0.4$  radian. In order to obtain these ranges, the calibration voltage must be reduced. The following table gives the calibration setting for various  $\Delta\theta$  limits.

$\theta$ Limit (radian)	CAL	Multiply Reading By
0.1	1%	1
0.2	0.498%	2
0.3	0.331%	3
0.4	0.247%	4
0.5	0.196%	5
0.6	0.162%	6
0.7	0.137%	7
0.8	0.118%	8
0.9	0.104%	9
1.0	0.092%	10

For these settings, the  $\Delta\theta$  limit is always a reading of 10 on the lower meter scale with the range switch set at 0.1 radian. Since use of this table sets the value correct at full scale where the accuracy of the bridge (in percent) is the best, the additional error introduced at readings less than full scale is negligible compared with the instrument error, up to full-scale values of about 0.8 radian. Note also that since the calibration is not made at full scale, it is more likely to be in error.

Figure 25 gives a complete scale for a  $\pm 1$  radian, full-scale range when the calibration is set to 0.092%. The maximum added error here is just over 3% of full scale.

5.7 UNBALANCED LOADING ON TRANSFORMER. Impedance placed across one side of the transformer to ground has little effect due to the tight coupling of the transformer and its low resistance. This feature has important advantages for many measurements since stray impedances may be placed across one transformer winding. Figure 26 shows a simple equivalent circuit, with shunt impedances  $Z_1$  and  $Z_2$  across the two halves of the winding. Here  $\ell_p$  and  $r_p$  do not cause an unbalance because both  $E_1$  and  $E_2$  are reduced by a voltage drop in the primary.

If the leakage inductance and resistance are assumed equal for the two secondary windings (a very good approximation), it can be shown that the only important error is a fixed, additive error of

$$\Delta Y (r + j\omega\ell)$$

$$\text{where } \Delta Y = Y_1 - Y_2 = \frac{1}{Z_1} - \frac{1}{Z_2}$$

which is most important on the most sensitive ranges. If only one side is loaded with an impedance,  $Z$ , the error becomes:

$$\frac{r + j\omega\ell}{Z} = Y (r + j\omega\ell)$$

where the error is positive if placed across the unknown half of the secondary winding. The value of  $r$  is less than 0.1 ohm at low frequencies and less than 0.2 ohm at 100 kc. The value of  $\ell$  is below 0.8  $\mu\text{h}$ .

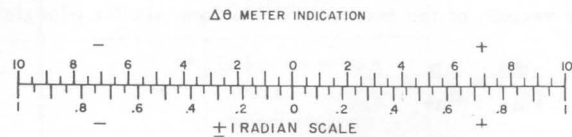

Figure 25.  $\pm 1$  Radian Scale.

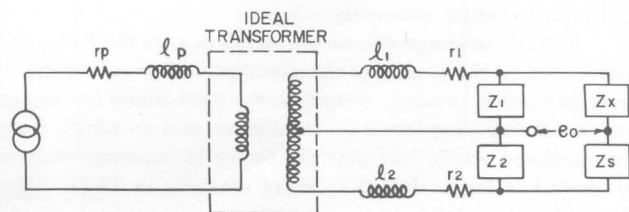

Figure 26. Equivalent Circuit of Transformer.

## GENERAL RADIO COMPANY

The table below gives formulas for calculating the  $\Delta Z$  and  $\Delta \theta$  errors for various loads at the various frequencies. The  $\Delta Z$  errors should be multiplied by 100 to give the percent error. The sign of the error is correct if the unknown transformer terminal is loaded.

Example: Shunting the unknown side of the transformer with 100 ohms at 10 kc will cause a  $\Delta Z$  error of less than

$$\frac{0.1}{100} \times 100\% = 0.1\%$$

and a  $\Delta \theta$  error of less than  $\frac{5}{100} \times 10^{-2} = 0.0005$  radian.

TYPE OF LOAD	$\Delta Z$ ERROR Multiply by 100%			$\Delta \theta$ ERROR Radians		
	R	L	C	R	L	C
UNIT	ohms	henries	$\mu f$	ohms	henries	$\mu f$
ERROR FORMULA	$\frac{r}{R}$	$\frac{\ell}{L}$	$-\omega^2 \ell C$	$\frac{\omega \ell}{R}$	$-\frac{r}{\omega L}$	$\omega r C$
FREQUENCY						
100 cps	$\frac{0.1}{R}$	$\frac{0.8}{L} \times 10^{-6}$	$-3C \times 10^{-7}$	$\frac{5}{R} \times 10^{-4}$	$-\frac{1.6}{L} \times 10^{-4}$	$7C \times 10^{-5}$
1 kc	$\frac{0.1}{R}$	$\frac{0.8}{L} \times 10^{-6}$	$-3C \times 10^{-5}$	$\frac{5}{R} \times 10^{-3}$	$-\frac{1.6}{L} \times 10^{-5}$	$7C \times 10^{-4}$
10 kc	$\frac{0.1}{R}$	$\frac{0.8}{L} \times 10^{-6}$	$-3C \times 10^{-3}$	$\frac{5}{R} \times 10^{-2}$	$-\frac{1.6}{L} \times 10^{-6}$	$7C \times 10^{-3}$
100 kc	$\frac{0.2}{R}$	$\frac{0.8}{L} \times 10^{-6}$	$-0.3C$	$\frac{0.5}{R}$	$-\frac{3}{L} \times 10^{-7}$	$0.14C$

5.8 MEASUREMENTS IN TERMS OF R, L, OR C DIFFERENCES. The  $\Delta Z$  meter can be interpreted as a  $\Delta R$ ,  $\Delta L$ , or  $\Delta C$  difference with negligible error if the standard elements are relatively pure. Obviously, if the components are pure, the impedance magnitude is equal to the value of R, L, or C, as the case may be. If the components are not pure, but  $\Delta D$  or  $\Delta Q$  equals zero, no error will result from considering the  $\Delta Z$  indication as an R, L, or C difference, since the complex impedance vectors of the two components form similar triangles so that:

$$\frac{\Delta |Z|}{|Z|_{av}} = \frac{\Delta R}{R_{av}} = \frac{\Delta X}{X_{av}}$$

The above relationship is useful, since a variable element can often be used to null the  $\Delta \theta$  meter and thus determine accurate  $\Delta R$ ,  $\Delta L$ , or  $\Delta C$  readings where large corrections would otherwise be necessary.

The  $\Delta Z$  readings can be corrected to give the R, L, or C differences, if the D or Q of the standard is known and the  $\Delta \theta$  meter indication is used. Note that the corrections below consist of a multiplying factor (percent error) and an additive correction (fixed error), and that the factor is important only as  $D_s$  (or  $Q_s$ ) is larger than 0.2, where the error is 2% (if  $\Delta D$  or  $\Delta Q = 0.1$ ).

The following formulas are given for determining the various equivalent series and parallel components of complex impedances. In these expressions the sign of  $\Delta \theta$  is as indi-

cated on the  $\Delta \theta$  meter, and the sign of  $D_s$  or  $Q_s$  is positive except for capacitive resistors (refer to paragraph 1.5).

Note: If the standard component is pure ( $D_s = 0$  or  $Q_s = 0$ ), the following expressions are greatly simplified.

a. Equivalent Series Resistance.

$$\frac{\Delta R}{R} = \frac{\Delta |Z|}{|Z|} (1 - Q_s \Delta \theta) - Q_s \Delta \theta - \frac{(\Delta \theta)^2}{2}$$

Note:  $Q_s$  is positive if the resistor is inductive, negative if the resistor is capacitive.

b. Equivalent Series Inductance or Inductive Reactance.

$$\frac{\Delta X_L}{X_L} = \frac{\Delta L}{L} = \frac{\Delta |Z|}{|Z|} (1 + D_s \Delta \theta) + D_s \Delta \theta - \frac{(\Delta \theta)^2}{2}$$

c. Equivalent Series Capacitance or Capacitive Reactance.

$$\frac{\Delta X_C}{X_C} = \frac{-\Delta C}{C} = \frac{\Delta |Z|}{|Z|} (1 - D_s \Delta \theta) - D_s \Delta \theta - \frac{(\Delta \theta)^2}{2}$$

d. Equivalent Parallel Conductance or Resistance.

$$\frac{\Delta G}{G} = \frac{-\Delta R}{R} = \frac{-\Delta |Z|}{|Z|} (1 - Q_s \Delta \theta) - Q_s \Delta \theta - \frac{(\Delta \theta)^2}{2}$$

## TYPE 1605-A IMPEDANCE COMPARATOR

e. Equivalent Parallel Capacitance or Capacitive Susceptance.

$$\frac{\Delta B_C}{B_C} = \frac{\Delta C}{C} = \frac{-\Delta|Z|}{|Z|} (1 - D_S \Delta\theta) - D_S \Delta\theta - \frac{(\Delta\theta)^2}{2}$$

Note:  $\Delta\theta$  is positive if the standard is the purer component.

f. Equivalent Parallel Inductance or Inductive Susceptance.

$$\frac{\Delta B_L}{B_L} = \frac{-\Delta L}{L} = \frac{-\Delta|Z|}{|Z|} (1 + D_S \Delta\theta) + D_S \Delta\theta - \frac{(\Delta\theta)^2}{2}$$

Note:  $\Delta\theta$  is negative if the standard is the purer component.

5.9 MEASUREMENT OF  $\Delta D$  AND  $\Delta Q$ . If  $D_S$  and  $D_X$  (or  $Q_S$  and  $Q_X$ ) are both less than 0.1 and  $\Delta Z$  is less than 10%, the  $\Delta\theta$  meter indication may be interpreted directly as  $\Delta D$  or  $\Delta Q$  with negligible error.

The  $D$  and  $Q$  of the standard and unknown could be greater than 0.1 without exceeding the range of the instrument, which limits  $\Delta\theta$  to 0.1 radian. If either or both  $D$ 's (or  $Q$ 's) is greater than 0.1, a correction should be applied. This correction is:

$$\Delta D = \Delta\theta(1 + D_S D_X) \quad \text{or} \quad \Delta Q = \Delta\theta(1 + Q_S Q_X)$$

or, in terms of  $D_S$  (or  $Q_S$ ) and  $\Delta\theta$ :

$$\Delta D = \frac{\Delta\theta(1 + D_S^2)}{1 \pm D_S \Delta\theta} \quad \text{or} \quad \Delta Q = \frac{\Delta\theta(1 + Q_S^2)}{1 \pm Q_S \Delta\theta}$$

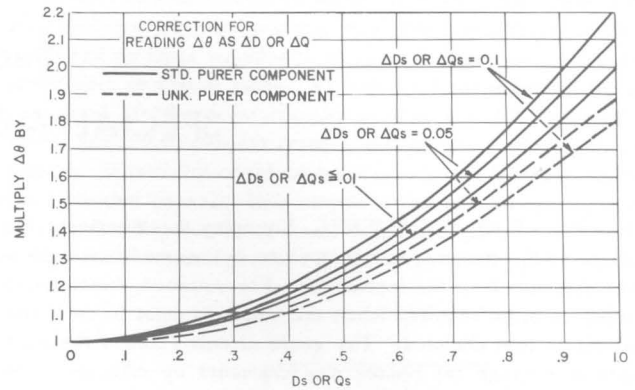

Figure 27.  
Correction Factor to Obtain  $D$  or  $Q$  from  $\theta$ .

Figure 27 shows a plot of the correction factor necessary for a correct determination of  $\Delta D$  or  $\Delta Q$ . Note that there are two values for this function. Use the solid curve if the standard is the purer component, the dash-line curve if the unknown is the purer component.

The correct signs for  $\Delta D$  or  $\Delta Q$  measurements are given in the table below. In the table, all  $D$ 's and  $Q$ 's are positive except the  $Q$  of a capacitive resistor (see Figure 5). The table also gives the signs for  $\Delta R$ ,  $\Delta L$ , and  $\Delta C$  measurements.

For convenient reference, the table is reprinted on the inside rear cover of this book.

### INTERPRETATION OF METER SIGNS

ΔZ METER			Δθ METER	
When Measuring:	Meter Reads	+ Indication Means	Meter Reads	+ Indication Means
ΔZ	$\frac{ Z_x  -  Z_s }{ Z_x  +  Z_s }$	Unknown has larger impedance	$\theta_x - \theta_s$	Unknown has larger $\theta$ (measured ccw on Z plane)
ΔY	$\frac{ Y_x  -  Y_s }{ Y_x  +  Y_s }$	Unknown has smaller admittance	$-(\phi_x - \phi_s)$	Unknown has smaller $\phi$ or larger $\theta$
ΔR	$\frac{R_x - R_s}{R_x + R_s}$ *	Unknown the larger resistor	$Q_x - Q_s$ **	Unknown more inductive (less capacitive)
ΔL	$\frac{L_x - L_s}{L_x + L_s}$ *	Unknown the larger inductor	$-(D_x - D_s)$ **	Unknown has less loss (higher Q)
ΔC	$\frac{C_x - C_s}{C_x + C_s}$ *	Unknown the smaller capacitor (larger reactance)	$D_x - D_s$ **	Unknown has more loss (larger D)

\* Good only for pure elements (refer to paragraph 5.8).

\*\* Good only if both  $D_S$  and  $D_X$  (or  $Q_S$  and  $Q_X$ ) are less than 0.1 (refer to paragraph 5.9).

Note: For reverse connections,  $x$  and  $s$  are interchanged. This is useful in measurements of admittance and capacitance to avoid the minus sign.



## Section 6

### SPECIAL MEASUREMENTS

6.1 REMOTE MEASUREMENTS. For many measurements, one or both of the external impedances to be measured must be at some distance from the instrument. For instance, remote positioning is often required when the unknown must be in a special jig or test chamber. The guard circuit extends the high-impedance range for remote measurements by effectively reducing the stray capacity to ground that would be added by cable shields.

Two wires are, of course, necessary to attach the unknown component to the instrument. The effect of capacity from the transformer lead to ground is negligible (refer to paragraph 5.7), and this lead, because of its low impedance, is relatively insensitive to pickup, although a shield may be necessary in some cases. The common lead is at high impedance if the unknown impedance is high, and a shield should be used to prevent pickup and to remove the capacity between the two leads, which would otherwise shunt the unknown. If this shield were grounded, the capacity from the common lead to ground would increase the input capacity and greatly reduce the impedance range (refer to paragraph 5.3). Connection of this shield to the guard point and use of the instrument in the OPERATE GUARDED position effectively reduces the added capacity by a factor of about 30, permitting use of a rather long cable with only a slight addition to input capacity.

The guard point is the outer conductor of the Type 874 Connector on the input connection. Thus shielded leads using Type 874 Connectors can be plugged directly into the instrument when the terminal (874-MB) is removed. A Type 874-T Connector can be used to provide a separate connection for the standard if this component is not located near the unknown.

#### 6.2 DIRECT OR TRANSFER IMPEDANCE MEASUREMENTS ON THREE-TERMINAL NETWORKS.

6.2.1 NULL METHOD. When it is necessary to measure the impedance or admittance between two terminals, each of which has finite impedance to a third terminal (A, Figure 28), it is possible to use the instrument as a null device in order to make the effect of the other two impedances ( $Z_a$  and  $Z_b$ ) negligible. In a conventional bridge it is possible to remove the effect of one of these impedances by putting it across the source or detector. The other impedance, however, is left across one arm of the bridge, where it will usually cause an error. This type of measurement is possible on the Type 1605-A if a variable standard is used (see Figure 29). Because impedance shunting one transformer winding has so little effect (refer to paragraph 5.7), one of the unwanted impedances ( $Z_a$ ) may usually be placed across it with negligible error. This puts the other unwanted impedance,  $Z_b$ , across the detector. If the detector is nulled (both meters reading zero) by variation of the standard,  $Z_b$  has no effect on the balance conditions, although it does reduce the sensitivity of the detector. The value of the unknown at null is, of course, equal to that of the standard, and

can be measured in terms of impedance or admittance. In general, the standard should consist of two adjustable components for a balance of both magnitude and phase. These components may be in series or parallel. If series variable components are used to make both the real and imaginary components of the standard adjustable, care should be taken to keep the capacity from the junction to ground as small as possible, since this capacity can cause a large error. Figure 30 shows an example.

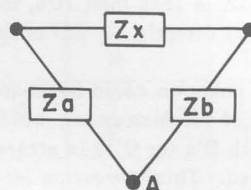

Figure 28.  
Three-Terminal Unknown.

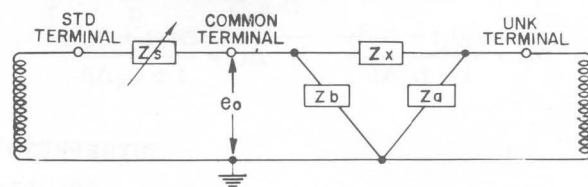

Figure 29.  
Direct Impedance Measurement Using Variable Standard.

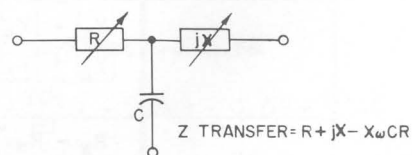

Figure 30.  
Possible Error When Series-Connected  
Variable Standards Used.

6.2.2 USE OF THE GUARD POINT FOR THREE-TERMINAL MEASUREMENTS. If the guard circuit could have zero output impedance and a gain of unity, the third terminal (A, Figure 28) could be connected to the guard point, and the effect of  $Z_a$  and  $Z_b$  would be negligible on the measurement, unless  $Z_a$  were so small as to load the transformer (refer to paragraph 5.7). But these ideal conditions are never met; the output impedance is finite and the gain slightly less than one. However, under certain conditions, this use of the guard terminal works well.

If point A is grounded, the reading is

$$\frac{Z_x - Z_s}{\frac{Z_x + Z_s}{2}} = 1 + \frac{Z_s}{2Z_b}$$

If the guard circuit is used the reading is approximately:

$$1 + \frac{Z_s(1 - K) + \frac{Z_o Z_s}{2Z_a Z_b}}{2Z_b}$$

where:  
 $Z_o$  = output impedance of guard circuit  $\approx 20\Omega$  in series with  $1.0\mu f$   
 $K$  = guard circuit gain  $\approx 0.97$

Note that use of the guard circuit adds a fixed error (in the numerator), which is small if  $Z_o$  is small, but this use reduces the percent error in the denominator. Thus if  $Z_b$  is much greater than  $Z_s$ , it may be best to ground point A, since the error may be small. In this instance  $Z_a$  should be the lower of the two stray impedances. The effects of  $Z_b$  on attenuation and phase shift can be calculated as described in paragraph 5.3, since  $Z_b$  just increases the detector input admittance.

If  $Z_s$ ,  $Z_a$ , and  $Z_b$  are of the same order of magnitude (so that  $\frac{Z_s}{Z_b}$  is not small), and they are large compared with  $Z_o$ , it is more desirable to use the guardpoint. This is especially true if the deviations,  $\Delta Z$  and  $\Delta \theta$ , are large so that the fixed error,  $\frac{Z_o Z_s}{Z_a Z_b}$ , is negligible.

This guard method is most useful when small direct capacitors are to be measured and the impedances  $Z_a$  and  $Z_b$  are just stray capacity.

6.2.3 DIRECT ADMITTANCE DIFFERENCE USING EXTERNAL AMPLIFIER. With the use of an external circuit that gives constant current gain (a, Figure 31), the instrument may be set up to read the real and imaginary components of the direct admittance difference between two components. The general setup is shown in Figure 31, where the meters will read the real and imaginary parts of  $2(Y_1 - Y_2)aR_L$  (times 100% for the  $\Delta Z$  meter).

If the input impedance is low, the stray impedance,  $Z_b$ , will have little effect, as will  $Z_a$ , and direct admittance of three-terminal networks can be measured.

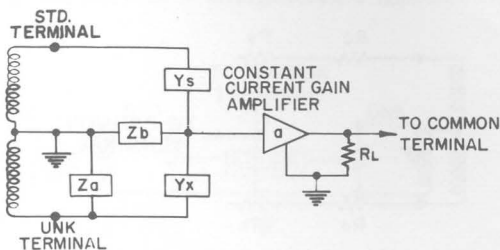

Figure 31.

Setup for Direct Admittance Difference Measurement Using External Amplifier.

One possible circuit is shown in Figure 32. Other circuits, perhaps using transistors, may give better results. This circuit has an input impedance of about 15 ohms at 1 kc and a current gain of almost unity. With this circuit using an  $R_L$  of 10 kilohms, a 10-percent reading indicates a difference of 5  $\mu mhos$ , and a 0.01-percent reading indicates a 0.005- $\mu mho$  unbalance. Sensitivity could be increased by an increase in  $R_L$  or a. Note that capacity from output to ground will cause phase shift, so that  $R_L$  should be small at high frequencies, the connecting lead short, and the OPERATE GUARDED position used.

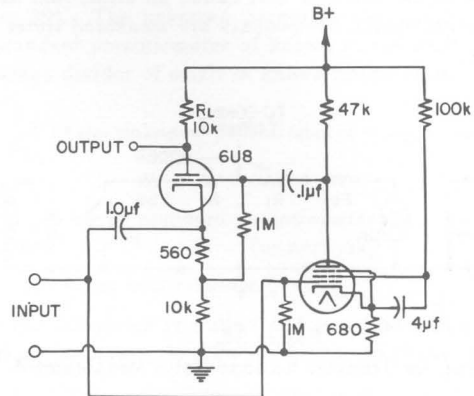

Figure 32.

Suggested Amplifier Circuit for Direct Admittance Measurement.

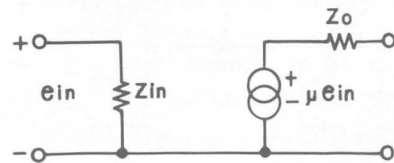

Figure 33.

Equivalent Circuit of General Three-Terminal Network.

6.3 MEASUREMENT OF TRANSFER VOLTAGE RATIOS. Although the instrument is designed primarily for impedance measurements, some of its features (direct indication, immunity from impedance shunting of the transformer) make it useful in other measurements, even though some extra equipment is needed.

In the three-terminal network shown in Figure 33 (two-terminal-pair network with common ground),  $Z_{in}$  is the input impedance with the output open-circuited ( $Z_{11}$ ),  $Z_o$  is the output impedance with the input shorted ( $\frac{1}{Y_{22}}$ ), and  $\mu$  is the open-circuit voltage gain that is to be measured. The circuit may in general be either active or passive. The general setup for such a measurement is shown in Figure 34. Because voltages applied to the two networks are of opposite phase, two open-circuit output voltages are added, and the meters indicate the real and imaginary parts of  $\mu_x - \mu_s$ . Therefore, if the  $\mu$  of the standard network is known, that of the unknown can be easily determined. If the transfer voltage ratios of the standard and unknown networks have opposite signs, the networks should be connected to the same transformer terminal.

The simple resistive adder network of Figure 34 is sometimes adequate. However, there are several restrictions on the use of the simple passive adder. If such an adder is used, the indication would be:

$$\frac{\mu_x(R_1 + Z_{OS}) - \mu_s(R_2 + Z_{OX})}{R_1 + Z_{OS} + R_2 + Z_{OX}}$$

so that  $R_1 + Z_{OS}$  should equal  $R_2 + Z_{OX}$  very closely if small differences in  $\mu$  are to be measured. Also, if  $R_1$  and  $R_2$  are to be very large in order to swamp out  $Z_O$  differences, the input impedance of the detector will cause an error, just as it does when high-impedance components are measured (refer to paragraph 5.3).

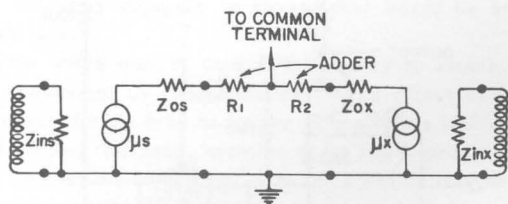

Figure 34. Setup for Transfer Voltage Ratio Measurement.

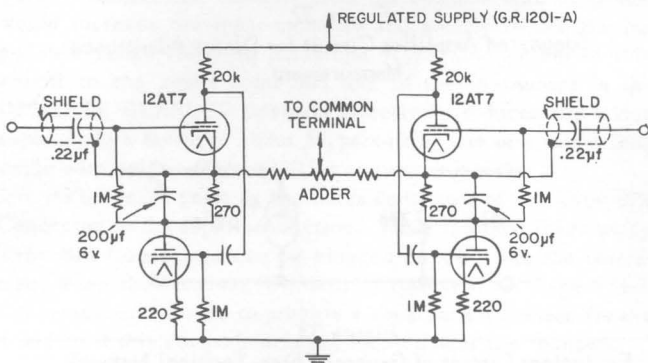

Figure 35. Suggested Electronic Adder Circuit.

A simple isolating circuit is useful to avoid these difficulties. A suggested circuit (Figure 35) provides high input impedance so that the output impedances,  $Z_{OX}$  and  $Z_{OS}$ , have negligible effect even when the adder resistors are of low impedance. The driven shields shown are useful for reducing any loading effects of stray capacitance on the outputs of the networks.

With either type of adder, there is also a possibility of a small error due to the unbalanced loading of the transformer by the  $Z_{in}$  of each network if these input impedances are low and and of different value (refer to paragraph 5.7). To correct for this effect, connect the adder across the transformer terminals with the standard and unknown networks in place, and adjust either the transformer loading or the adder to give zero indications on the two meters.

The meter indications should be interpreted as fractions (i.e. 0.01 rad = 0.01, 1% = 0.01). The high sensitivity of the detector permits determination of both components of  $\mu$  to within 0.0001 without requiring null adjustment.

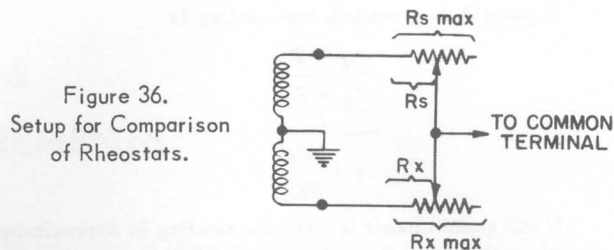

Figure 36. Setup for Comparison of Rheostats.

An important application of this transfer voltage measurement is in the measurement of the standard linearity and phase shift of potentiometers (refer to paragraphs 6.4.2 and 6.4.3).

6.4 MEASUREMENTS ON POTENTIOMETERS.

6.4.1 COMPARISON OF GANGED POTENTIOMETERS USED AS RHEOSTATS. If potentiometers are to be checked as two-terminal variable resistors, several different types of indications are possible. The simplest setup is that shown in Figure 36, where the indication is:

$$\frac{R_x - R_s}{R_x + R_s}$$

This indication will become very large near the low end of the potentiometers, and therefore is not a very realistic way to compare or to specify potentiometers. A common way of specifying potentiometers is to allow a fixed error,  $\pm R_A$ , plus a percent error,  $\pm B\%$ . This could also be expressed as  $\pm A\%$  of  $R_{max}$ ,  $\pm B\%$  of  $R$ , where

$$\frac{R_A}{R_{max}} \times 100\% = A\%$$

If the standard is a perfect potentiometer, we can set up the measurement so that this combined tolerance limit becomes a fixed meter indication. Figure 37 shows the setup.

If  $R_O = \frac{A}{B} R_{max}$ , a  $\Delta Z$  meter indication of  $B\%$  will be the allowable limit for any value of  $R$ .

Example: To compare a 1000-ohm potentiometer, whose specifications are  $\pm 1\% \pm 2$  ohms, to a "perfect" standard 1000-ohm potentiometer.

$$R_A = 2 \Omega \quad A = \frac{2}{1000} = 0.002 = 0.2\% \quad B = 0.01 = 1\%$$

$$R_O = \frac{A}{B} R_{max} = \frac{0.002}{0.01} \times 1000 = 200 \Omega$$

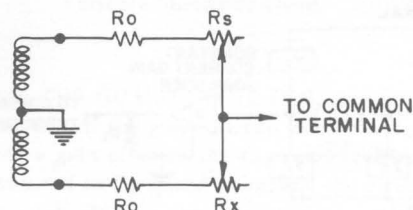

Figure 37. Preferred Setup for Comparison of Rheostats.

## TYPE 1605-A IMPEDANCE COMPARATOR

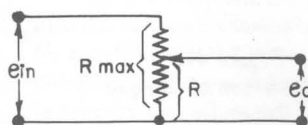

Figure 38.  
Potentiometer Used As  
Voltage Divider.

The tolerance on the meters is a 1% indication. At the low end of the potentiometer, the 2-ohm fixed error is important and  $\frac{2\Omega}{R_o} = 1\%$ . At the high end the allowable error is  $1\% + 0.2\Omega = 12$  ohms, which is 1% of the total resistance.

**6.4.2 MEASUREMENT OF STANDARD INDEPENDENT LINEARITY.** The standard independent linearity of a potentiometer is the tolerance indicating the allowable deviation from linearity expressed as a percent of the maximum value of the potentiometer. This specification is therefore independent of the maximum value of the potentiometer. Thus, if the deviation from linearity at any point is  $\delta\%$ , the resistance at that point is:

$$R = \theta R_{\max} + \delta\% R_{\max}$$

where  $\theta$  is the normalized rotation.

Therefore:

$$\frac{R}{R_{\max}} = \theta + \delta\% = \frac{e_o}{e_{in}}$$

See Figure 38.

This quantity can be measured with the setup of Figure 39. If the standard potentiometer is linear, the  $\Delta Z$  meter will read  $\delta\%$ . (The division by two of the common adder circuit has been taken into account.)

The unknown potentiometer can also be compared with a voltage divider if a dial is used on the unknown to set the angle correctly. This is a point-by-point procedure, but could be more precise if the voltage divider were of high accuracy (General Radio Type 1454-A Decade Voltage Divider is recommended).

An electronic adder circuit (refer to paragraph 6.3) is particularly useful for this measurement, since it makes it possible to compare potentiometers of different resistances since the output impedance of the potentiometer then has no effect.

**6.4.3 PHASE SHIFT OF POTENTIOMETERS.** The comparison of phase angle of potentiometers used as two-terminal, variable resistors is a straightforward impedance-difference

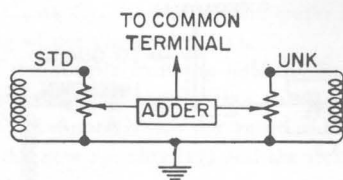

Figure 39.

Setup for Measurement of Standard Independent  
Linearity or Phase Shift.

measurement. The phase-shift difference between two potentiometers can be measured, or a potentiometer can be compared with a fixed resistor. When small phase shifts of large potentiometers are measured, the input capacity to the Type 1605-A can become large due to the connections necessary. It is desirable and simple to adjust the  $\Delta Z$  meter for a null in order to reduce the error in reading  $\Delta\theta$  due to this input capacity. With a  $\Delta Z$  indication of zero, the input phase-shift error (B) has no effect [ $\Delta\theta_T = \Delta\theta_A (1 + A) + B\Delta Z_A$ , refer to paragraph 5.3].

The measurement of voltage phase shift of a potentiometer is a voltage transfer ratio measurement (the setup is shown in Figure 39). The unknown potentiometer can be compared with a standard potentiometer of known phase shift, or with a fixed voltage divider of small or known phase shift.

$$\text{If } \frac{E_o}{E_{in}} \text{ of the unknown potentiometer} = \mu_x = \mu_{rx} + j\mu_{ix}$$

$$\text{and } \frac{E_o}{E_{in}} \text{ of the standard potentiometer} = \mu_s = \mu_{rs} + j\mu_{is}$$

(or network)

the  $\Delta\theta$  meter will read:  $\mu_{ix} - \mu_{is}$

If the  $\Delta Z$  meter is nulled and  $\mu_{rs}$  (the real part of the attenuation) is known, then the difference in phase shift is:

$$\Delta\theta = \tan^{-1} \frac{\mu_{ix} - \mu_{is}}{\mu_{rs}} \approx \frac{\mu_{ix} - \mu_{is}}{\mu_{rs}} \quad \text{if } \theta \text{ is small.}$$

If a fixed divider is used,  $\mu_{is}$  can be very small, and  $\mu_{ix}$  read directly. Note that a high-precision divider is not necessary.

An electronic adder is desirable to reduce possible errors. Care should be taken not to add capacity on the outputs of the potentiometers. The suggested circuit (Figure 35) provides guardpotentials to drive shields on the connecting leads.

### 6.5 MEASUREMENTS ON SMALL CAPACITORS.

**6.5.1 GENERAL.** The high-impedance limitation resulting from input impedance shunting the common input terminal to ground can usually be avoided by correct choice of test frequency. In the measurement of small capacitors, the phase-shift error B (refer to paragraph 5.3) can be avoided by the use of a high frequency, but the attenuation error, A, always causes difficulty as the compared capacitors approach the value of the input capacity. This input capacity also includes any capacity to ground from the leads connecting the components to the "common" terminal. Therefore these leads should be short and, if possible, with shields connected to the guard potential.

Shields are usually necessary to reduce hum pickup, which can overload the amplifier and cause an offscale indication. The instrument, as well as nearby equipment and the operator, should be grounded.

The following paragraphs describe different methods that can be used for these low-capacity measurements.

**6.5.2 CORRECTION FOR INPUT CAPACITANCE EFFECTS.** The indicated percent capacity difference can be multiplied by

$$\frac{C_x + C_s + C_{in}}{C_x + C_s} \approx \frac{2C_s + C_{in}}{2C_s} = 1 + \frac{C_{in}}{2C_s}$$

to determine the correct  $\Delta C\%$ . The main difficulty here is in determining  $C_{in}$  accurately enough to obtain the required precision. In the OPERATE GUARDED position, this input capa-



city is  $3.8 \mu\mu\text{f}$  when measured to the terminal post on the instrument itself. If any leads are tied to this terminal, the capacity is increased.

One way of measuring input capacity is shown in Figure 40. An error signal is produced by large capacitors  $C_1$  and  $C_2$  (Figure 40a), where  $C_2 > 20C_1$ . A known small capacitor,  $C_3$ , is then put on the input lead (Figure 40b). The ratio of the two indications is  $\frac{C_3}{C_3 + C_{in}}$ .

Another way of measuring input capacity is simply to compare two known capacitors and calculate  $C_{in}$ . The advantage of this method is that the connections for the calibrating and the desired measurements can be identical in order to keep  $C_{in}$  constant.

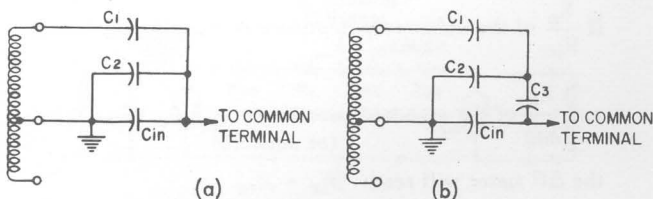

Figure 40. Measurement of Detector Input Capacitance.

6.5.3 MEASUREMENT OF  $\Delta C$  IN  $\mu\mu\text{F}$ . When very small capacitors are measured, the indication will be:

$$\frac{2\Delta C}{C_x + C_s + C_{in}} \approx \frac{2\Delta C}{C_{in}}$$

If  $C_{in}$  is known, the indication will be a factor times  $\Delta C$ . This gives the difference in terms of the capacitive difference in  $\mu\mu\text{f}$  rather than in percent. If capacity is added to  $C_{in}$ , this type of indication will be available at higher capacity levels. With no added capacity,  $C_{in}$  is about  $4 \mu\mu\text{f}$ , which would result in a  $\Delta Z$  reading of 0.02% to indicate a  $\Delta C$  of  $0.0004 \mu\mu\text{f}$ . Since this sensitivity is not often required, it is desirable to increase  $C_{in}$  with known capacitance so that  $C_{in}$  is more accurately known, the above equation is more nearly correct, and hum pickup is reduced.

6.5.4 DIRECT CAPACITY METHODS. Small capacitors can be measured by the null method (refer to paragraph 6.2.1), where the input capacity affects only the sensitivity of balance. This method, of course, requires a small, calibrated capacitor for use as a standard. Another method is the use of the low-input-impedance amplifier (refer to paragraph 6.2.3), which gives an output voltage proportional to the  $\Delta C$  in  $\mu\mu\text{f}$  rather than percent on the  $\Delta\theta$  meter. For this method,  $\Delta\theta = 2(2\pi f)\Delta C R_L$ .

With an  $R_L$  of 7.87 k at 100 kc, one division on the most sensitive range is  $0.01 \mu\mu\text{f}$ . Very large stray capacity to ground can be tolerated if the amplifier input impedance is low.

6.6 MEASUREMENTS ON GANGED CAPACITORS. Measurements on ganged capacitors are straightforward in principle, but such difficulties as pickup and input capacity require special care. The simple connection would give an indication of  $\Delta C$  in percent, although a correction for  $C_{in}$  may be necessary if the minimum value of  $C$  is small. Capacitor specifications are often given as  $\pm C_A \mu\mu\text{f} \pm B\%$ , which is analogous to the potentiometer specification in paragraph 6.4. This complex tolerance can be made to give a constant meter indication by

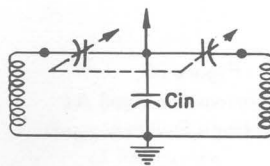

Figure 41. Comparison of Ganged Capacitors.

increasing the input capacity with added fixed capacitors. This setup is shown in Figure 41. The tolerance limit will be an indication of  $B\%$  regardless of capacitor setting if

$$C_{in} = \frac{2C_A}{B}(100).$$

Example: Two  $1000\text{-}\mu\mu\text{f}$  ganged capacitors should track to  $\pm 2 \mu\mu\text{f} \pm 1\%$ .

$$C_A = 2 \mu\mu\text{f} \quad B = 1\%$$

$$C_{in} = \frac{2C_A(100)}{B} = \frac{2(2 \mu\mu\text{f})(100)}{1\%} = 400 \mu\mu\text{f}$$

A reading of 1% will show the tolerance limit. At  $100 \mu\mu\text{f}$ , the maximum allowable difference is

$$\frac{1}{100} \times 100 \mu\mu\text{f} + 2 \mu\mu\text{f} = 3 \mu\mu\text{f}.$$

$$\Delta Z = \frac{\Delta C_{max}}{\frac{C_x + C_s + C_{in}}{2}} = \frac{3}{\frac{100 + 100 + 400}{2}} = \frac{3}{300} = 1\%$$

At  $1000 \mu\mu\text{f}$ , maximum allowable difference is

$$\frac{1}{100} \times 1000 \mu\mu\text{f} + 2 \mu\mu\text{f} = 12 \mu\mu\text{f}.$$

$$\Delta Z = \frac{\Delta C_{max}}{\frac{C_x + C_s + C_{in}}{2}} = \frac{12}{1200} = 1\%$$

Another method for comparison of direct capacity would be to use the low-input-impedance amplifier described in paragraph 6.2.3. Here the  $\Delta\theta$  reading would be proportional to the capacitance difference in  $\mu\mu\text{f}$  rather than in percent.

6.7 PRECISE MEASUREMENT OF SMALL-DISSIPATION-FACTOR CAPACITORS. When the dissipation factor of small capacitors is measured, a large  $\Delta Z$  reading can result in an error caused by input capacity phase shift (paragraph 5.3), as well as other errors (paragraph 5.3). If the  $\Delta Z$  meter is nulled, these difficulties are removed. If the capacitor is very small, there is also an attenuation error (A) requiring correction. One setup that has been used to measure very small values of D is shown in Figure 42.

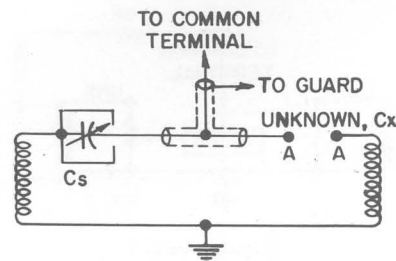

Figure 42. Measurement of Small Dissipation Factors.

## TYPE 1605-A IMPEDANCE COMPARATOR

In the setup shown, the component to be tested is plugged into the unknown terminals. The variable capacitor is balanced for a null on the  $\Delta Z$  meter. Thus the unknown quantity is read directly on the variable capacitor, and the dissipation factor is read on the  $\Delta\theta$  meter.

### 6.8 MEASUREMENTS ON DIELECTRIC SAMPLES.

**6.8.1 GENERAL.** The high sensitivity of the Type 1605-A makes it useful for measurements on dielectric samples. The direct indication of  $D$  on the  $\Delta\theta$  meter can greatly speed up dissipation-factor measurements that ordinarily require a precise  $D$  balance, and the  $\Delta Z$  sensitivity and sign indication speed up the capacitive balance necessary for measurement of dielectric constant.

For precise measurement of both these quantities on solid dielectric samples, the Type 1690-A Dielectric Sample Holder is recommended.  $D$  measurements are possible without such a holder; simply make a capacitor out of the sample by applying aluminum foil to each side, and compare it with a standard capacitor to determine the value of  $D$ . However, for precise  $D$  values, stray losses and stray capacitances must be controlled, a difficult task without a precision sample holder. A recommended setup for both  $K$  and  $D$  measurements is shown in Figure 43.

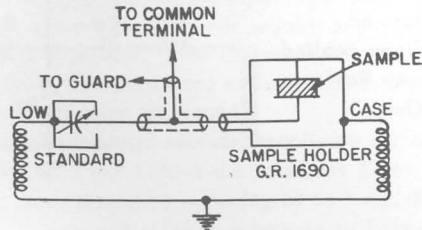

Figure 43.  
Measurements on Dielectric Samples.

The measurement procedure is similar to that described in the Type 1690-A Dielectric Sample Holder Instruction Book, paragraph 4.1. It is repeated below, using the same terminology except that the  $D$  indication becomes a  $\Delta\theta$  reading. The Type 1690-A Instruction Book should be studied carefully for familiarization with the measurements.

#### 6.8.2 PROCEDURE.

- a. Set up the equipment as shown in Figure 43. Use the OPERATE GUARDED position.
- b. Insert the sample in the holder and screw the top electrode down until it is firmly in contact, as indicated by the release of the drive mechanism.
- c. Balance  $C_S$  until the  $\Delta Z$  meter reads zero, and record the reading of  $C_S$  as  $C_1$ . Record the  $\Delta\theta$  meter indication ( $\Delta\theta_1$ ) and the spacing of the electrodes ( $t_1$ ).
- d. Remove the sample from the holder. Rebalance the  $\Delta Z$  meter for zero reading by readjusting the micrometer capacitor (electrodes). Do not disturb the value of  $C_S$ .
- e. Record the new spacing ( $t_2$ ) and the new reading on the  $\Delta\theta$  meter ( $\Delta\theta_2$ ).

**6.8.3 CALCULATION.** The calculation of  $K$  and  $D$  is the same as that given in the Type 1690-A Instruction Book (paragraph 4.12), except that  $\Delta\theta_1$  and  $\Delta\theta_2$  replace  $D_1$  and  $D_2$ .

**6.8.4 PRECAUTIONS.** The input impedance of the Type 1605-A can cause errors described in paragraph 5.3. However, if  $\Delta Z$  is balanced to zero, the error due to  $R_{in}$  is greatly reduced. At low frequencies, the  $\Delta Z$  balance must be very precise since the factor  $B$  (refer to paragraph 5.3) is large. The factor  $A$  (paragraph 5.3) will cause an error if the capacity of the unknown is small, in which event the calculated  $D_x$  should be multiplied by  $1 + A = 1 + \frac{C_{in}}{2C_x}$  for the correct value. Here  $C_{in}$  is the input capacity of the bridge (refer to paragraph 6.5.2). This error is kept to a minimum by the use of shields tied to the guard terminal.

A small error in determining  $C_x$  is possible due to the effect of the  $D$  on the  $\Delta Z$  balance. There are two sources of error here. First, because the magnitude,  $|Z|$ , is larger than the reactance,  $\frac{1}{\omega C}$  ( $|Z| = \frac{1}{\omega C} \sqrt{1 + D^2}$ ), there is a small error if  $D$  is not zero. However, the error is less than 0.01% if  $D$  is less than 0.01. A second source of error is the factor  $B$ , which results in a  $\Delta Z$  error and therefore an error in the indication  $C_1$  when  $\Delta Z$  is set to zero. The reading  $C_1$  is in error by  $B\Delta\theta$  times 100%. Since  $\Delta\theta_1$  is approximately  $D_x$ , this error depends on  $C_x$ ,  $D_x$ , and the frequency, and is usually negligible at 1 kc or higher.

Measurements at 100 cycles are difficult because of the phase shift errors due to  $B$ , and also the presence of hum, which makes precise meter indications difficult.

**6.9 MEASUREMENTS ON BALANCED TRANSFORMER WINDINGS.** The instrument compares two impedances, but if these two components are coils wound on the same core and connected properly, the  $\Delta Z$  meter will read approximately  $\frac{\Delta N}{N} \times 100\%$  where  $\Delta N$  is the turns difference and  $N$  is the average number of turns ( $\frac{N_x + N_s}{2}$ ). The accuracy with which this quantity is indicated depends upon the  $Q$  of the inductors and the coefficient of coupling. However, it is usually sufficient to indicate an unbalance as long as the  $Q$ 's of the two windings are about the same. Turns may then be added to bring the windings into balance.

The actual indications are given below for the setup of Figure 44.

$$\Delta Z \text{ reads } 2 \frac{\frac{L_1 - L_2}{L_1 + L_2 + 2M} + \frac{r_1^2 - r_2^2}{\omega^2(L_1 + L_2 + 2M)^2}}{1 + \frac{(r_1 + r_2)^2}{\omega^2(L_1 + L_2 + 2M)^2}}$$

If  $r_1 \approx r_2$  and  $\frac{r}{\omega L}$  is small:

$$\Delta Z \text{ reads } \frac{L_1 - L_2}{L_1 + L_2 + 2M} \cdot \frac{1}{2}$$

If  $K = \frac{M}{\sqrt{L_1 L_2}} \approx 1$  (good coupling)

$$\Delta Z \text{ reads } \frac{L_1 - L_2}{\frac{L_1 + L_2 + 2\sqrt{L_1 L_2}}{2}} = \frac{\sqrt{L_1} - \sqrt{L_2}}{\frac{\sqrt{L_1} + \sqrt{L_2}}{2}}$$

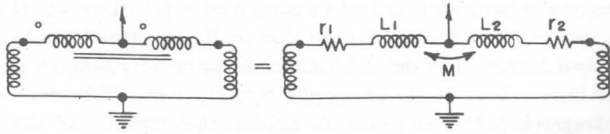

Figure 44. Measurements on Balanced Transformer Windings.

If  $L \sim N^2$

$$\Delta Z \text{ reads } \frac{N_1 - N_2}{\frac{N_1 + N_2}{2}} = \frac{\Delta N}{N_{\text{avg}}}$$

6.10 MEASUREMENTS WITH APPLIED D-C VOLTAGE AND CURRENT.

6.10.1 GENERAL. This instrument is not particularly suited for the comparison of components with applied d-c voltage or current. However, since this type of measurement often must be made, the following paragraphs describe possible test setups and the difficulties involved.

The errors caused by the components added to apply the direct current should be independent of the value of the dc, so that the readings taken with the applied source set at zero could be considered initial balances and subtracted from the test readings.

6.10.2 D-C VOLTAGE APPLIED TO CAPACITORS. A possible setup where voltage is to be applied to both the standard and unknown capacitors is shown in Figure 45. The resistor R shunts the input circuit and could cause a  $\Delta\theta$  error, the same error caused by the input resistance (refer to paragraph 5.3), except that here the factor B is  $\frac{1}{2\omega C_s R}$ . If the capacitors have low leakage, R could be very large and the error negligible. The maximum voltage that should be applied to the common terminal is 400 volts.

A setup where voltage is to be applied to only one capacitor is shown in Figure 46. R should be as large as possible and  $C_y$  should be very much larger than  $C_x$ .

Figure 45. D-C Voltage Applied to Standard and Unknown Capacitors.

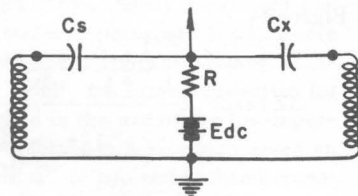

6.10.3 D-C VOLTAGE APPLIED TO RESISTORS. Figure 47 shows a possible setup where the voltage is to be applied to both resistors. The applied voltage will be divided between  $R_x$  and  $R_s$  so that the actual voltage across each component should be measured if the components differ by an appreciable amount. The maximum current through the resistors should be less than 100 ma.

If the current is to pass through only one resistor, a d-c path across the detector and a blocking capacitor are necessary (Figure 48). This shunt path may be a resistor ( $R_y$ ) or an inductor. The resistor will cause a voltage division resulting in a lower applied voltage on the unknown, but will result in an

error that is simpler to correct for; the  $\Delta R$  reading should be multiplied by  $1 + \frac{R_s}{2R_y}$ .  $C_y$  and  $C_w$  should be as large as possible.

Figure 46. D-C Voltage Applied to Unknown Capacitor Only.

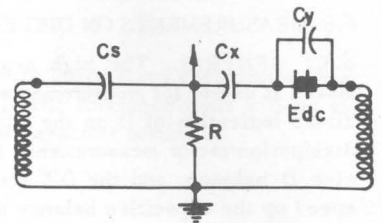

Figure 47. D-C Voltage Applied to Standard and Unknown Resistors.

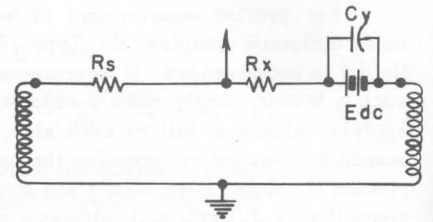

Figure 48. D-C Voltage Applied to Unknown Resistor Only.

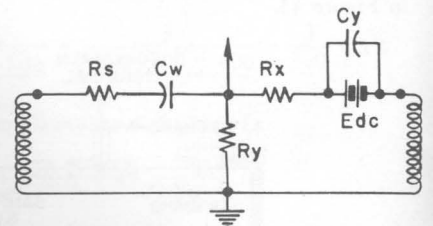

Figure 49. D-C Current Applied to Standard and Unknown Inductors.

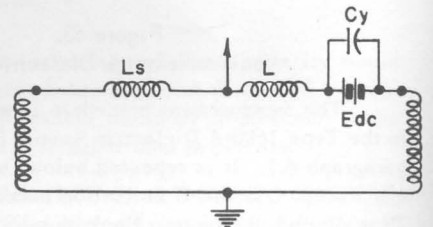
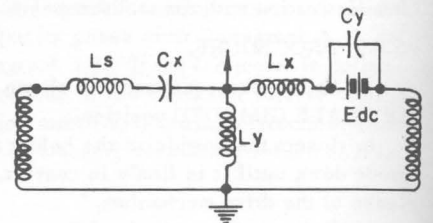

Figure 50. D-C Current Applied to Unknown Inductor Only.



6.10.4 DIRECT CURRENT IN INDUCTORS. If dc is to flow through both the standard and the unknown inductors, a possible setup is as shown in Figure 49. The capacitor  $C_y$  should be as large as possible so as not to affect the value of the impedance between the unknown terminals. The maximum current that should pass through the transformer windings (secondary) is about 100 ma. (This current may cause a small error at 100 cycles if small  $\Delta\theta$  values are measured in the presence of large  $\Delta Z$  values, due to the resulting distortion in the transformer.)

## TYPE 1605-A IMPEDANCE COMPARATOR

If the current is to pass through only one inductor, a possible setup is as shown in Figure 50. The necessity of a d-c path across the detector input will cause error unless  $L_y$  is very large.  $C_x$  and  $C_y$  must also be large.

**6.11 USE OF EXTERNAL RECORDERS.** The meter terminals are brought out to a plug at the rear of the instrument so that the meter voltages can be used for recording or sorting. The full-scale voltage (one end of the scale to the other) is about 120mv, and the impedance of the meter is about 600 ohms. When the meter is zeroed (centered) there is no output voltage. Both meter terminals are about 45 volts off ground. These conditions result in several restrictions on the recorder (or d-c amplifier) used:

- a. The input impedance should be high compared with 600 ohms, although an error of only a few percent caused by shunting the meter could be corrected by recalibration.
- b. The sensitivity should be high, 100 mv full scale.
- c. The drift should be low.
- d. Unless the recorder or amplifier input is differential, its low terminal must be plus 45 volts, which will result in a potential on the recorder case unless it is isolated from the low terminal.

Recorders can be classified into two types, the high input impedance (servo) type and the low input impedance (galvanometer) type. The servo type does not require a d-c amplifier if its sensitivity is adequate. One instrument of this type, the Varian Model G-10, has been used satisfactorily. The case of this recorder was 45 volts off ground.

The galvanometer-type recorder requires a d-c amplifier. The General Radio Type 1230-A d-c amplifier gives good results and will drive recorders requiring up to 5 ma. The Type 1230-A can be connected in such a way as to keep its case at ground potential. The output of the Type 1230-A will be above ground, but most galvanometer-type recorders have both terminals insulated from the case.

**6.12 AUTOMATIC SORTING.** The Type 1605-A has been built into fully automatic sorting machines where the equipment must also consist of proper parts-handling apparatus and a d-c amplifier and amplitude selector to actuate the equipment when the tolerance is exceeded. It would be impossible to describe here the complete sorting systems, especially since each system is apt to have its own unique requirements.

Sorting machines can be used to check components both before and after assembly into subassemblies. Systems have been made that check components on etched board subassemblies. Since components on an etched board will generally be interconnected, measurements will not be made on single components, but rather at different points in various networks. The principle of comparison is valuable here, since the standard could be an etched assembly with components selected to make it as near "design center" as possible.

The ability of the Type 1605-A to measure phase-angle difference as well as magnitude differences results in added information that can reduce the number of test points necessary.

**6.13 CONNECTION OF SHIELDED, THREE-TERMINAL CAPACITORS.** The shield of a shielded, three-terminal capacitor, such as the General Radio Type 1422-CB, may be con-

nected either to guard (refer to paragraph 4.7) or to ground. Both connections cause an error when small capacitors are measured, and the error resulting from each connection should be evaluated to see which is smaller.

If the shield is guarded, there is a fixed error of  $\frac{C_a C_b}{C_s C_o}$

$\times 100\%$ , where  $C_o$  (the output capacitance of the guard) is  $1 \mu f$  and  $C_a$ ,  $C_b$ , and  $C_s$  are defined in Figure 50a (also refer to paragraph 6.2.2). This error is not a percent of the reading, but rather a constant-error term that is present no matter what the capacitance difference.

If the shield is tied to ground, the Capacitance  $C_a$  is added to the detector input capacitance,  $C_{in}$ , increasing the error described in paragraph 5.3. The resulting magnitude error, when capacitors are measured, is approximately  $\frac{C_{in}}{C_x + C_s} \times 100\%$ . This is a percent of the reading, and is therefore negligible if only 1% or less.

In either arrangement, the shield of the lead connecting the capacitor to the common terminal should be tied to guard, and the shield of the other lead (to the STANDARD or UNKNOWN terminal) should be grounded, if shielded wire is used. Note that these shields are, therefore, not joined. Also if the capacitor shield is guarded, it must be insulated from ground.

**6.14 RAPID CHECKING OF DIODE AND TRANSISTOR CAPACITANCE AND CONDUCTANCE.** The Type 1605-A can be used for production checking of small capacitance and conductance values of back-biased diodes and transistor collector junctions. The basic circuit is shown in Figure 50b. The resistor  $R_{in}$  shunts the input of the Type 1605-A detector, causing a large attenuation in the signal. If  $R_{in}$  is small compared to the impedance of the diode, then the Type 1605-A will read:

$$\Delta Z \text{ meter reading} \approx 2GR_{in} \quad \Delta \theta \text{ meter reading} \approx 2\omega CR_{in}$$

where  $G$  and  $C$  are the equivalent parallel conductance and capacitance of the diode or transistor being tested.

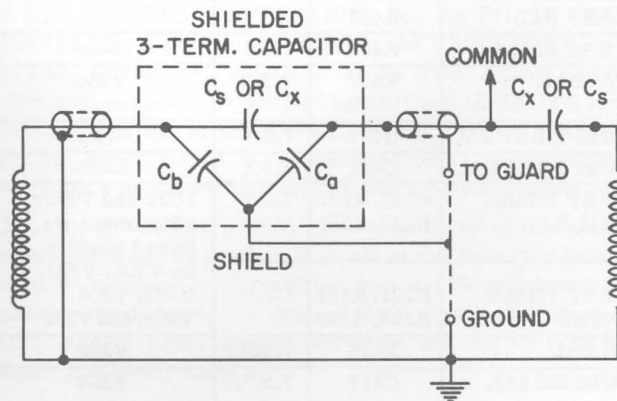

Figure 50a. Measurements of Shielded Three-Terminal Capacitors.



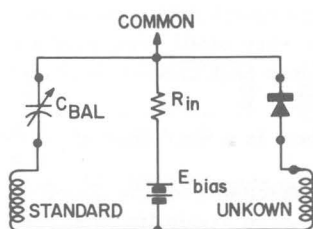

Figure 50b.  
Measurement of Semiconductor  
Capacitance and Conductance.

For example, if  $R_{in} = 500$  ohms, the  $\Delta Z$  meter will read  $3 \mu v$  full scale on the 0.3% range, and the  $\Delta \theta$  meter will read 4.8 pf full scale on the 0.003 radian range at 100 kc.

If impedance is connected between the standard terminal and the common terminal, the meters will read the difference in capacitance and conductance. A variable capacitance is shown which is useful in canceling out the capacitance of the leads and any test jig used.

## Section 7 SERVICE AND MAINTENANCE

7.1 GENERAL. The two-year warranty given with every General Radio instrument attests the quality of materials and workmanship in our products. When difficulties do occur, our service engineers will assist in any way possible.

In case of difficulties that cannot be eliminated by the use of these service instructions, please write or phone our Service Department, giving full information of the trouble and of steps taken to remedy it. Be sure to mention the serial and type numbers of the instrument.

Before returning an instrument to General Radio for service, please write to our Service Department or nearest district office (see back cover), requesting a Returned Ma-

terial Tag. Use of this tag will insure proper handling and identification. For instruments not covered by the warranty, a purchase order should be forwarded to avoid unnecessary delay.

7.2 ADJUSTMENTS. Tube replacement and tube aging affect the accuracy of the Type 1605-A. Table 7.1 and paragraph 7.3 describe the adjustments necessary to preserve the instrument's original accuracy. Periodic readjustment is recommended every three to six months, depending upon usage.

Most of these adjustments can be made without external equipment except for a few common electrical components.

TABLE 7.1 TABLE OF ADJUSTMENTS

Name	Ref Desig	Refer to Para	Tubes That Affect Adjustment	Other Adjustments Affected	Function
REGULATION	R508	7.3.1	V503	Most adjustments affected by large change	Sets B+ level of regulated supply.
OSC LEVEL	R109	7.3.2	V101	$\theta$ REF PHASE ANGLE adjustments	Sets oscillator level.
100kc FREQ	C118	7.3.3	V101	100kc $\theta$ REF PHASE ANGLE; 100kc Z REF PHASE ANGLE; 100kc SIG BAL	Sets frequency of 100-kc oscillator position.
Z REF BAL	R403	7.3.4	—	—	Precisely balances $\Delta Z$ adder.
$\theta$ REF BAL	R453	7.3.5	—	—	Precisely balances $\Delta \theta$ adder.
BIAS BAL	R337	7.3.6	V304	—	Balances output impedance of push-pull amplifier (V304) by changing d-c bias.
100kc Z REFBAL	C401	7.3.7	—	—	Balances stray capacity of $\Delta Z$ adder.
100kc $\theta$ REFBAL	C451	7.3.8	—	—	Balances stray capacity of $\Delta \theta$ adder.
$\theta$ REF PHASE ANGLE	R225, R227, R229, R231	7.3.9	100c and 100kc adjustment affected slightly by V301, V302, V303, V304, V201, and V202	—	Sets angle of $\theta$ reference voltage correct at each frequency.
Z REF PHASE ANGLE	R221, R222, R223, R224	7.3.10		—	Sets angle of Z reference voltage correct at each frequency.
SIG BAL	R328	7.3.9.1	V303	—	Balances push-pull amplifier signal.
100kc SIG BAL	C314	7.3.9.2	V303	100kc Z and $\theta$ REF PHASE ANGLE	Balances push-pull amplifier signal at 100 kc.
$\theta$ METER CAL	R464	7.3.11	V403, V453	—	Sets $\Delta \theta$ meter sensitivity so that when $\Delta Z$ meter is calibrated, $\Delta \theta$ is also.
OFF SCALE LIMIT	R351	7.3.12	V302	—	Sets sensitivity of off-scale indicator and relay circuit.

## TYPE 1605-A IMPEDANCE COMPARATOR

### 7.3 ADJUSTMENT PROCEDURE.

7.3.1 REGULATION. Set B+ to 250 volts  $\pm 3\%$  (V501, pin 3 or 6 to chassis).

7.3.2 OSC LEVEL. Set CAL control to center of its range, FREQUENCY switch to 1 kc, and IMPEDANCE DIFFERENCE switch to 1%. Then adjust the OSC LEVEL control (R109) to give full-scale (1%) reading.

7.3.3 100-KC FREQ. Set the FREQUENCY switch to 100 kc. Compare the signal (on transformer terminal on panel) with an accurate 100-kc signal. Set for zero beat by adjusting the 100-kc FREQ control (C118).

7.3.4 Z REF BAL. Set the CAL control fully counterclockwise, the FREQUENCY switch to 1 kc, the function switch to ZERO, and the IMPEDANCE DIFFERENCE switch to 10%. Use the panel ZERO adjustment to zero the IMPEDANCE DIFFERENCE meter. Then set the CAL control fully clockwise and adjust the Z REF BAL control (R403) to zero the IMPEDANCE DIFFERENCE meter.

7.3.5  $\theta$  REF BAL. Adjustment procedure is the same as for Z REF BAL (paragraph 7.3.4), except adjust the  $\theta$  REF BAL (R453) to zero the PHASE ANGLE DIFFERENCE meter.

7.3.6 BIAS BAL. Set the CAL control to the 1% level, the FREQUENCY switch to 1 kc, the function switch to ZERO, the IMPEDANCE DIFFERENCE switch to 10%, and the PHASE ANGLE DIFFERENCE switch to 0.10 radian. Use the ZERO adjustment to zero both meters. Then set IMPEDANCE DIFFERENCE to 0.3% and PHASE ANGLE DIFFERENCE to 0.003 radian. Adjust the BIAS BAL control (R337) to restore zero on both meters.

7.3.7 100-KC Z REF BAL. Adjustment procedure is the same as for the Z REF BAL (paragraph 7.3.4), except set the FREQUENCY switch to 100 kc, and use the 100-kc Z REF BAL control (C401) to zero the IMPEDANCE DIFFERENCE meter.

7.3.8 100-KC  $\theta$  REF BAL. Adjustment procedure is the same as for the Z REF BAL (paragraph 7.3.4), except set the FREQUENCY switch to 100 kc, and use the 100-kc  $\theta$  REF BAL control (C451) to zero the PHASE ANGLE DIFFERENCE meter.

7.3.9  $\theta$  REF PHASE ANGLE and SIGNAL BAL. Set the CAL control to the 1% level, the IMPEDANCE DIFFERENCE switch to 10%, the PHASE ANGLE DIFFERENCE switch to 0.003 radian, and the function switch to OPERATE UNGUARDED. Attach two similar 100-ohm carbon resistors (matched to within 5%) to the STANDARD and UNKNOWN terminals. Shunt first one resistor and then the other with a 2-kilohm carbon resistor to produce a plus and minus impedance difference of about 5% (for -AH use a 6-kilohm resistor; produces a difference of about 1.7%). Be careful to add as little capacitance as possible across the 100-ohm resistors. Then proceed as directed in the following paragraphs.

7.3.9.1 Set the FREQUENCY switch to 100 c. Adjust the 100- $\theta$  REF PHASE ANGLE control (R225) until the deflection of the PHASE ANGLE DIFFERENCE meter does not change when the applied  $\Delta Z$  error is reversed. Then adjust the SIGNAL BAL control (R328) until there is no meter deflection as the 5% impedance difference is applied.

7.3.9.2 Set the FREQUENCY switch to 100 kc. Adjust the 100-kc  $\theta$  REF PHASE ANGLE (R231) and the 100-kc SIGNAL

BAL (C314) controls so that there is no deflection of the PHASE ANGLE DIFFERENCE meter as the 5% impedance is applied. These two adjustments are somewhat interdependent, so that several adjustments will normally be necessary.

7.3.9.3 Set the FREQUENCY switch to 1 kc. Adjust the 1-kc  $\theta$  REF PHASE BAL adjustment (R227) so that there is no deflection of the PHASE ANGLE DIFFERENCE meter as the 5% impedance difference is applied.

7.3.9.4 Set the FREQUENCY switch to 10 kc. Adjust the 10-kc  $\theta$  REF PHASE BAL control (R229) so that there is no deflection of the PHASE ANGLE DIFFERENCE meter as the 5% impedance difference is applied.

7.3.10 Z REF PHASE ANGLE ADJUSTMENTS. Set the PHASE ANGLE DIFFERENCE switch to 0.10 radian, the IMPEDANCE DIFFERENCE switch to 0.3%, and the function switch to OPERATE GUARDED. Attach two 100-ohm resistors to the STANDARD and UNKNOWN terminals. These resistors should be matched or padded until they produce an impedance-difference error of from -0.1 to +0.3 percent.

7.3.10.1 Set the FREQUENCY switch to 100 c and the CAL control to the 1% level. Shunt the UNKNOWN resistor with a 1- $\mu$ f capacitor. Adjust the 100-cycle Z REF PHASE ANGLE adjustment (R224) to produce a -0.2% change in the IMPEDANCE DIFFERENCE meter indication.

7.3.10.2 Set the FREQUENCY switch to 1 kc and the CAL control to the 1% level. Follow the procedure of paragraph 7.3.10.1, except use a 0.1- $\mu$ f capacitor and adjust the 1-kc Z REF PHASE ANGLE control (R223) to produce a -0.2% change in impedance difference.

7.3.10.3 Set the FREQUENCY switch to 10 kc and the CAL control to the 1% level. Follow the procedure of paragraph 7.3.10.1, except use a 0.01- $\mu$ f capacitor and adjust the 10-kc Z REF PHASE ANGLE adjustment (R222) to produce a -0.2% change in impedance difference.

7.3.10.4 Set the FREQUENCY switch to 100 kc and the CAL control to the 1% level. Follow the procedure of paragraph 7.3.10.1, except use a 0.001- $\mu$ f capacitor and adjust the 100-kc Z REF PHASE ANGLE control to produce a -0.2% change in impedance difference.

7.3.11  $\theta$  METER CALIBRATION. Set the PHASE ANGLE DIFFERENCE switch to 0.01 radian, the FREQUENCY switch to 1 kc, and the CAL control to the 1% level. Attach two 100-ohm  $\pm 1\%$  resistors to the STANDARD and UNKNOWN terminals. Shunt the standard resistor with a 0.01- $\mu$ f capacitor ( $\pm 1\%$ ). Adjust the  $\theta$  CAL adjustment (R464) for an indication of +0.0063 on the PHASE ANGLE DIFFERENCE meter.

7.3.12 OFF SCALE LIMIT. The sensitivity of this adjustment may be set as desired. It is set at the factory to be actuated by a signal level resulting from a 15% unbalance. To adjust, merely apply the desired limit signal and adjust the OFF SCALE LIMIT control (R351) so that the OFF SCALE lights just barely come on.

### 7.4 TROUBLE-SHOOTING PROCEDURE.

7.4.1 GENERAL. The following paragraphs contain recommended corrective procedures to be followed in the event of

## GENERAL RADIO COMPANY

various types of malfunction. In case of trouble, find the symptom in the following list, then refer to the paragraph indicated.

<u>Trouble</u>	<u>Paragraph</u>
Instrument inoperative	7.4.2
One meter inoperative	7.4.3
OFF SCALE indicator inoperative	7.4.4
OFF SCALE indicator does not turn off	7.4.5
Both meters off scale	7.4.6
One meter off scale	7.4.7
Meter zero shifts with range	7.4.8
Meter zero shifts with frequency	7.4.9
Meter zero shifts with level	7.4.10
IMPEDANCE DIFFERENCE indication wrong	7.4.11
PHASE ANGLE DIFFERENCE indication wrong	7.4.12
Magnitude difference causes phase angle difference reading	7.4.13
Phase angle difference causes impedance difference reading	7.4.14
Insufficient calibrating voltage	7.4.15
Meter zeros drift excessively	7.4.16

7.4.2 INSTRUMENT INOPERATIVE. If the panel lights are lit, the OFF SCALE light is off, and yet neither meter shows deflection when it should, proceed as follows:

a. Check the transformer output voltage (UNKNOWN or STANDARD terminal to ground). This should be about 0.3 volt rms at the test frequency. (Be sure that the CAL control is not fully counterclockwise.) If no signal appears at the transformer output, check the transformer input voltage (AT101, AT102). This should be about 14 volts rms at the signal frequency when the instrument is calibrated.

(1) If no signal is present on the transformer primary, the trouble is in the oscillator circuit.

(a) Check to see whether the oscillator is inoperative at all frequencies. If it is inoperative at only one frequency, check the capacitors and switching associated with that frequency.

(b) Check tube pin voltages and resistances against those given in Table 7.2.

(c) Replace tubes and check whether the trouble persists.

(d) Check thermistor R122 visually to make sure it is not open (i.e. filament broken).

(2) If a signal is present on the transformer primary but not on the secondary (note that there is a 40-to-1 step-down ratio), proceed as follows:

(a) Check transformer connections.

(b) Check transformer windings for continuity. Turn the instrument off and use the high-resistance range of the ohmmeter to avoid putting too much current through the primary.

b. If there is a signal on the output of the bridge transformer, check the signal on the output of the amplifier (TP304 or TP305) with the function switch in either OPERATE position (with an impedance unbalance) and again with the function switch in the CAL position.

(1) If no signal is present at the amplifier output with the function switch in either position, the trouble is in the amplifier circuit.

(a) Check to see whether there is a signal at the input to the amplifier (TP303). If there is, trace the signal through the amplifier.

(b) Check tube pin voltages and resistances against those given in Table 7.5.

(2) If a signal is present with the function switch in the CAL position but not the OPERATE position (with a bridge unbalance), the trouble is in the amplifier input circuit or in the function switch.

(a) Check the common bridge terminal to make sure that there actually is a bridge unbalance. Then trace the signal on pin 7 of V301, and on TP301 and TP302. (The signal should be very nearly the same on all these points.)

(b) Check tube pin voltages and resistances against those given in Table 7.4.

c. If a signal appears at the amplifier output with the function switch in the OPERATE position, and yet neither meter shows deflection when bridge unbalances are applied, proceed as follows:

(1) Visually check to see that the heaters of the deflection tubes (V401, V402, V403, V451, V452, V453) are lit. These tubes are on a common series string with the ballast tube V504.

(2) Check reference voltages at TP403 and TP453. If the reference voltages are missing, trace the reference signals from the inputs TP201 and TP202, and check voltages on the reference amplifier board against those given in Table 7.3.

(3) Check to see that the meter circuits are grounded at TP404 and TP405. The relay opens these circuits, but the OFF SCALE light or the relay contacts could be defective.

(4) Check detector voltages against those given in Table 7.6.

7.4.3 ONE METER INOPERATIVE. If only one meter is inoperative, the trouble is limited to the corresponding detector circuit and its associated reference voltage and range switch.

a. Work the meter ZERO panel adjustment and see whether the meter reacts. If it does not, the difficulty is in the detector itself.

(1) Check the voltage on TP404 (for IMPEDANCE meter) or TP454 (for PHASE ANGLE meter). This point should be grounded if the OFF SCALE indicator is not lit.

(2) Check meter connections. Use an ohmmeter carefully here so as not to put too high a current through the meter.

b. If the meter indication varies as the ZERO control is worked, the difficulty is in the reference amplifier, range switch, or adder. Check the reference voltage at TP403 (for IMPEDANCE meter) or TP453 (for PHASE ANGLE meter). Voltage should be about 22 volts rms.

(1) If no reference voltage is present, trace the reference signal through the reference amplifier from the input (TP201 for IMPEDANCE meter, TP202 for PHASE ANGLE meter).

(2) If the reference signal is present, check the range switch connections. Make sure a signal is present on the amplifier output and the adder inputs (TP401, TP402, TP451, and TP452) when the reference voltage is disconnected at TP403 or TP453.



## TYPE 1605-A IMPEDANCE COMPARATOR

**7.4.4 OFF SCALE INDICATORS INOPERATIVE.** If the OFF SCALE indicators will not light when a large unbalance (greater than 15% or 0.15 radian) is present, and the instrument is otherwise operative, the trouble is in the relay circuit.

a. Check to see that there is a signal of over 6 volts at TP306. If not, check to make sure that there is an unbalance present and check C317.

b. Check to see that the d-c voltage from pin 7 of V302 varies as an unbalance is applied. If not, check diodes D301 and D302.

c. Check to see that the plate voltage (pin 6 of V302) varies as a bridge unbalance is applied. A 20-percent bridge unbalance should effect a plate-voltage change of over 100 volts.

d. If the relay clicks and the meters zero when an unbalance is applied, but the indicator does not light, the bulb may be burned out.

e. If the relay does not click audibly although the plate voltage (at pin 6, V302) changes substantially (refer to step c), the relay may be defective.

**7.4.5 OFF SCALE INDICATORS DO NOT TURN OFF.**

a. If the OFF SCALE indicator lights do not go off when the function switch is set to ZERO, the trouble is probably in the relay amplifier tube (V302B), which must be conducting to keep the indicator off and the bridge operative.

(1) Replace V302 (12AT7).

(2) Check tube voltages on V302B, especially the grid voltage (pin 7), to make sure that the tube is not cut off. If the grid voltage is negative, some signal must be present at TP304, even though the instrument is set at ZERO. Trace this signal back through the amplifier.

b. If, with a small bridge unbalance, the OFF SCALE indicators do not go off when the function switch is set to OPERATE, but do go off when the switch is set to ZERO, proceed as follows:

(1) Zero the bridge externally by shorting the common bridge terminal to the panel ground terminal. If this turns off the OFF SCALE indicators, the trouble is either of the following:

(a) A large bridge unbalance. Note that the sensitivity of the OFF SCALE indicators may be reduced (refer to paragraph 7.3.12).

(b) Hum pickup on the common terminal, causing the relay to operate (refer to paragraph 7.3.12).

(2) If shorting the instrument externally does not turn off the indicators, but setting the function switch to ZERO does, the trouble is in either the amplifier input circuit or the function switch. Trace to its source the signal causing the relay operate.

**7.4.6 BOTH METERS OFF SCALE.** If both meters are off scale when the function switch is set to ZERO, proceed as follows:

a. Work the ZERO control to make sure it wasn't misadjusted.

b. Short-circuit pin 5, V401 to pin 1, V402 (B+3 to B+4), and see if this brings the meters back on scale. If it does, check these bias sources (resistors R521 through R527).

c. Short-circuit TP401 to TP402, and see if the IMPEDANCE DIFFERENCE meter comes back on scale. If it does, some signal is present on the amplifier, and this signal should be traced.

d. Check detector tube voltages against those given in Table 7.6.

**7.4.7 ONE METER OFF SCALE.** If only one meter is off when the function switch is set to ZERO, proceed as follows:

a. Work the ZERO control to make sure it wasn't misadjusted.

b. Set the range switch of the off-scale meter to a position between detented switch settings. If this does not bring the meter back on scale, the trouble is in the type 12AX7 meter tube V403 (or V453).

c. Short-circuit pin 1, V401 (V451) to pin 5, V402 (V452). If this brings the meter on scale, short-circuit TP401 (TP451) to TP402 (TP452).

(1) If short-circuiting TP401 (TP451) to TP402 (TP452) helps, the trouble is in the range switch (perhaps a wire-wound resistor is open).

(2) If the short circuit does not help, the trouble is in the adder resistors R401 through R405 (R451 to R455) or the capacitors C402 and C403 (C452 and C453).

d. If short-circuiting pin 1, V401 to pin 5, V402 doesn't help, short-circuit pin 1, V402 (V452) to pin 5, V401 (V451).

(1) If short-circuiting pin 1, V402 (V452) to pin 5, V401 (V451) helps, the trouble is in the B+ voltages. Check this supply (resistors R521 through R527).

(2) If the short circuit does not help, replace the type 6AL5 diodes V401 and V402 (V451 and V452).

**7.4.8 METER ZERO SHIFTS WITH RANGE.** If either meter zero shifts as the range switch position is changed (with the function switch at ZERO), there is an unbalance in the range switch.

a. If the shift is small and occurs in only the most sensitive range (0.3% or 0.003 radian), reset the BIAS BAL adjustment (refer to paragraph 7.3.6).

b. Short-circuit pin 7, V304 to pin 2, V304. If this helps, a signal is present in the amplifier, and it should be traced.

c. Check the attenuator resistors on the appropriate range switch.

**7.4.9 METER ZERO SHIFTS WITH FREQUENCY.** If the meter zero shifts as the test frequency is changed (with the function switch at ZERO), proceed as follows:

a. If the shift occurs in the 100-kc position, adjust the 100-kc REF BAL control (Z or  $\theta$ ), so that the zero at 100 kc coincides with that 1 kc.

b. If the shift occurs in the 100-cycle position, there is an unbalance in the detector time constants. Such an unbalance should not be more than one small meter division. If it is slightly more, resistor R407 and R409 (R457 or R459) can be padded to reduce the unbalance. If the unbalance is very large, some component has failed and should be replaced.



7.4.10 METER ZERO SHIFTS WITH LEVEL. If the meter zero shifts as the calibration level is changed (with the function switch at ZERO), reset the REF BAL control (Z or  $\theta$ ). (Refer to paragraph 7.3.4 or 7.3.5.)

7.4.11 IMPEDANCE DIFFERENCE INDICATION WRONG. If an accurately known impedance unbalance is applied, and the IMPEDANCE DIFFERENCE indication is in error, the internal calibration resistors (R301, R302, and R303) may have changed value. Pad these so that when the instrument is recalibrated, the indication is correct. However, first check that:

- a. the calibration has been made carefully,
- b. the IMPEDANCE DIFFERENCE meter has been zeroed carefully,
- c. the impedance range has not been exceeded.

7.4.12 PHASE ANGLE DIFFERENCE INDICATION WRONG. If an accurately known phase angle difference is measured and the indication is in error, the PHASE ANGLE DIFFERENCE meter may require recalibration (refer to paragraph 7.3.11). However, first make sure that:

- a. the  $\Delta Z$  calibration has been carefully made,
- b. the PHASE ANGLE DIFFERENCE meter has been carefully zeroed,
- c. the desired range has not been exceeded,
- d. the error is not due to the fact that the  $\theta$  error is small and the  $\Delta Z$  error is large (refer to paragraph 5.5).

7.4.13 MAGNITUDE DIFFERENCE CAUSES PHASE ANGLE DIFFERENCE INDICATION. If an impedance difference unbalance causes a phase angle difference indication, check to see whether the PHASE ANGLE DIFFERENCE indication reverses as the IMPEDANCE DIFFERENCE indication reverses. If it does, adjust the  $\theta$  REF PHASE ANGLE control. If it does not, adjust the SIG BAL control (refer to paragraphs 7.3.9 and 7.3.9.1). However, make sure that there is no phase angle difference between the standard and unknown components.

7.4.14 PHASE ANGLE DIFFERENCE CAUSES IMPEDANCE DIFFERENCE INDICATION. If a phase angle difference causes an impedance difference indication, adjust the Z REF PHASE ANGLE control (refer to paragraph 7.3.10). However, make sure that the indicated impedance difference is not actually present. Remember that the IMPEDANCE DIFFERENCE meter compares  $\Delta Z$ , not necessarily  $\Delta R$ ,  $\Delta C$ , or  $\Delta L$  (refer to paragraph 5.8).

7.4.15 INSUFFICIENT CALIBRATING VOLTAGE. If the CAL control is fully clockwise (maximum) and the IMPEDANCE DIFFERENCE meter reads less than 1% with the function switch at CAL, the oscillator level is low. Adjust the internal OSC LEVEL control (refer to paragraph 7.3.2). If sufficient level is still unobtainable, replace the oscillator tubes V101 and V102.

7.4.16 METER ZEROS DRIFT EXCESSIVELY. Some tubes used in the meter circuit drift more than others. If excessive drift is apparent, try changing V403 (IMPEDANCE DIFFERENCE meter) or V453 (PHASE ANGLE DIFFERENCE meter). If this does not help, try replacing V401 and V402 (or V451

and V452). Also, a defective ballast tube (V504) could cause drift due to changing line voltage.

7.5 TROUBLE-SHOOTING DATA. The data on the following pages, arranged by etched-board assembly, should be very helpful in pinpointing troubles. The difficulty can usually be traced to a particular board by analysis of the misbehaviour. To find the component causing the difficulty it is usually necessary to make voltage or resistance checks.

#### CAUTION

When replacing a component on an etched board, be careful not to destroy the bond between board and etched wiring by heat or by force. When removing the defective component, firmly grab the wire at the component side (the component may be clipped off first), and then, pulling on the wire, apply just enough heat to the solder point to free it. Before inserting the new component, make certain that an unobstructed passage exists, either by carefully drilling through from the component side or by removing the solder from the hole. When using the soldering iron to remove solder, draw the solder back along the conductor from the tab with quick strokes. Never apply the soldering iron to the etched board for more than five seconds at a time.

If the position of the board prohibits the above procedure, many components can be replaced as follows: destroy the old component, preserving enough wire to attach the replacement, then solder the new component in place.

For each etched board, the following data are given: top and bottom views of the board, with components and test points labeled; schematic diagram of the circuit; descriptive parts lists of components; and test voltage and resistance tables.

Both a-c and d-c voltages, as well as resistance to ground, are listed for each tube pin. Instruments used for these measurements were:

a. d-c voltages: General Radio Type 1806-A Electronic Voltmeter. A 20,000-ohm/volt voltmeter may be used except at high-impedance points, designated in the tables by asterisks.

b. a-c voltages: General Radio Type 1806-A Electronic Voltmeter. Values given are the rms values for sinusoidal waveforms (0.707 of the peak value for complex waves).

c. resistances to ground: any good ohmmeter can be used for these measurements. Turn power off and ground B+1 (C503), B+2 (C504), and d-c input (C501).

Actual voltages may vary considerably, since many of them depend directly on tube characteristics. Particular information about several of the measurements is given in numbered footnotes. All resistances are given in ohms, unless otherwise specified by k (kilohms) or M (megohms).

## TYPE 1605-A IMPEDANCE COMPARATOR

On the following pages appear parts lists, schematic diagrams, voltage and resistance tables, and top and bottom views of etched boards, which should prove helpful in troubleshooting. These data are arranged by circuit as follows:

Circuit	Page
Oscillator	30,31
Reference Amplifier	32,33
Input Cathode Follower	34,35
Signal Amplifier	36,37
Detectors	38,39
Power Supply	40,41
Range Attenuator Components	42

GENERAL RADIO COMPANY

OSCILLATOR

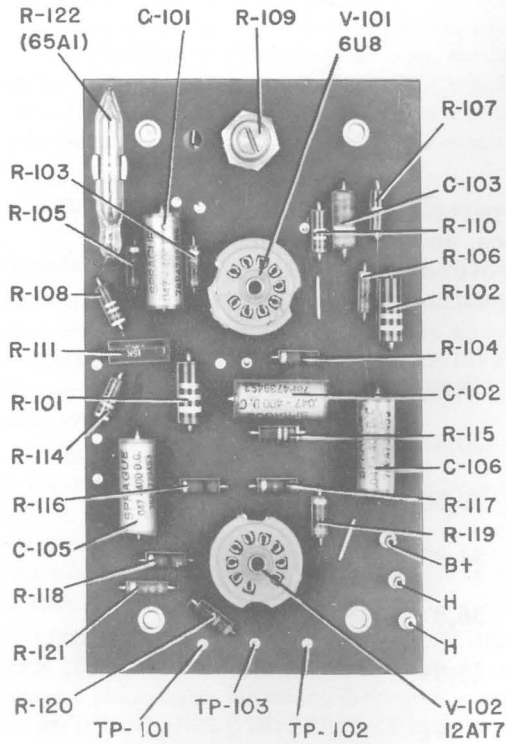

Figure 51.  
Top View, R-C Oscillator Circuit Board.

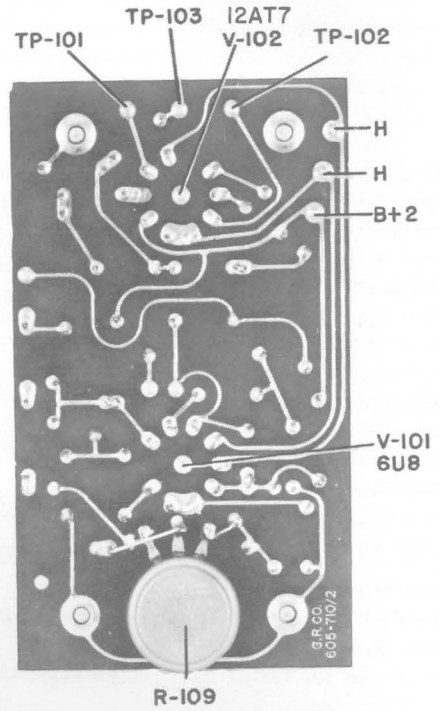

Figure 52.  
Bottom View, R-C Oscillator Circuit Board.

PARTS LIST

		GR No. (NOTE A★)				GR No. (NOTE A★)				
RESISTORS (Note B★)	R101	24	k	± 5%	1 w	REC-30BF	R122	Thermistor W. E. 21A or V. E. 65-A1	1605-41	
	R102	24	k	± 5%	1 w	REC-30BF	R131	2 M ±20%	POSC-12	
	R103	100	k	±10%	1/2 w	REC-20BF	R132	31.6 k ± 1%	REF-70	
	R104	100		±10%	1/2 w	REC-20BF	C101	0.047 ±10%	400dcwv	COW-25
	R105	1	M	±10%	1/2 w	REC-20BF	C102	0.047 ±10%	400dcwv	COW-25
	R106	1	M	±10%	1/2 w	REC-20BF	C103	2.2µmf ±10%	500dcwv	COC-21
	R107	220		±10%	1/2 w	REC-20BF	C105	0.047 ±10%	400dcwv	COW-25
	R108	47	k	±10%	1/2 w	REC-20BF	C106	0.047 ±10%	400dcwv	COW-25
	R109	25	k	±10%		POSC-11	C111	0.1 ± 1%	250dcwv	1605-209
	R110	68	k	±10%	1/2 w	REC-20BF	C112	0.01 ± 1%	500dcwv	COM-30E
	R111	15	k	± 1%	1/4 w	REF-65	C113	0.001 ± 1%	500dcwv	COM-30E
	R114	47	k	±10%	1/2 w	REC-20BF	C114	120µmf ± 2%	500dcwv	COM-20E
R115	47	k	±10%	1/2 w	REC-20BF	C115	0.05 ± 1%	100dcwv	1605-206	
R116	1	M	±10%	1/2 w	REC-20BF	C116	0.005 ± 1%	500dcwv	COM-30E	
R117	1	M	±10%	1/2 w	REC-20BF	C117	470µmf ± 1%	500dcwv	COM-20E	
R118	100		±10%	1/2 w	REC-20BF	C118	4-50µmf		COA-2L	
R119	100		±10%	1/2 w	REC-20BF					
R120	150		±10%	1/2 w	REC-20BF					
R121	2.2	k	±10%	1/2 w	REC-20BF					
						T101	TRANSFORMER	1605-301		

★ For NOTES refer to page 42.

# TYPE 1605-A IMPEDANCE COMPARATOR

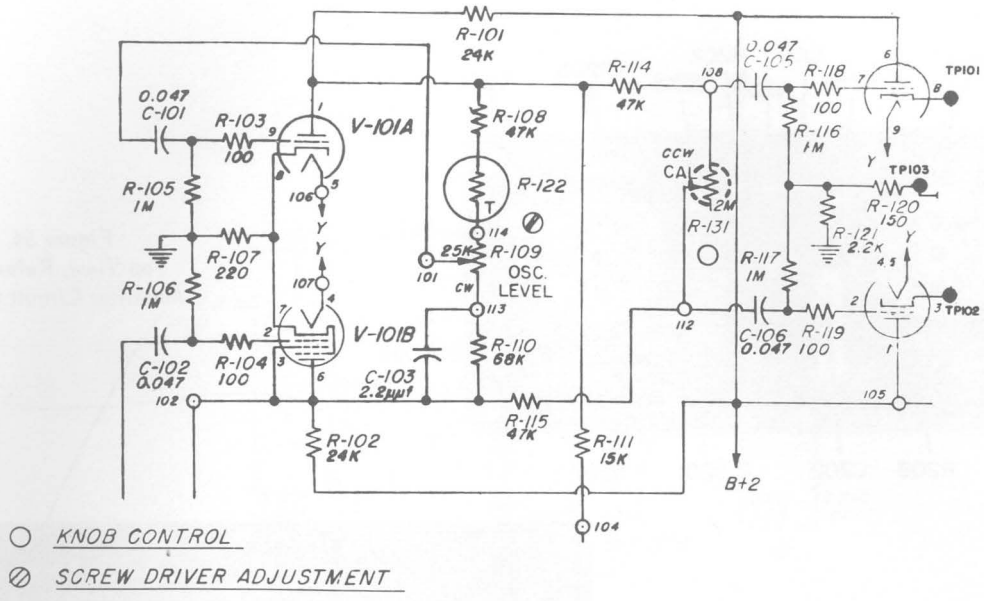

Figure 53.  
 R-C Oscillator Circuit Diagram.  
 (Components enclosed by broken lines not on etched board.)

TABLE 7.2  
 TEST VOLTAGES AND RESISTANCES

Switch and Control Settings:

FREQUENCY: 1 kc  
 Function: Any

CAL: for 1% calibration  
 Ranges: Any

Meters: Refer to paragraph 7.5.  
 Power off and plate supply grounded  
 for resistance measurements.

TEST POINT or TUBE	PIN	FUNCTION	VOLTS		RES TO GND	TEST POINT or TUBE	PIN	FUNCTION	VOLTS		RES TO GND
			DC	AC(rms)					DC	AC(rms)	
TP101		Transformer pri	25	14(a)	2.4 k	V 102 (12AT7)	1	Plate (B)B+2	230	0	0
TP102		Transformer pri	25	14(a)	2.4 k		2	Grid (B)	24*	14(a)	1 M
TP103		Pri. center tap	25	0-1(b)	2.4 k		3	Cathode (B)	25	14(a)	2.4 k
V 101 (6U8)	1	Plate (A)	100	20(c)	24 k		4	Heater	0	3.4(b)	0
	2	Grid (B)	0*	—	1 M		5	Heater	0	3.4(b)	0
	3	Screen (B)	100	20	24 k		6	Plate (A)	230	0	0
	4	Heater	0	3.4(d)	0		7	Grid (A)	24*	14(a)	1 M
	5	Heater	0	2.9(d)	0		8	Cathode (A)	25	14(a)	2.4 k
	6	Plate (B)	100	20(c)	24 k		9	Heater	0	2.9(b)	0
	7	Cathode (B)	2.1	0	220						
	8	Cathode (A)	2.1	0	220						
	9	Grid (A)	0*	1.1	1 M						

\* High impedances; use VTVM

(a) Depends on CAL setting

(b) May not be 0v here due to slight unbalance of push-pull signal, which should cause no difficulty.

(c) Depends on setting of OSC LEVEL control.

(d) Depends on line voltage



REFERENCE AMPLIFIER

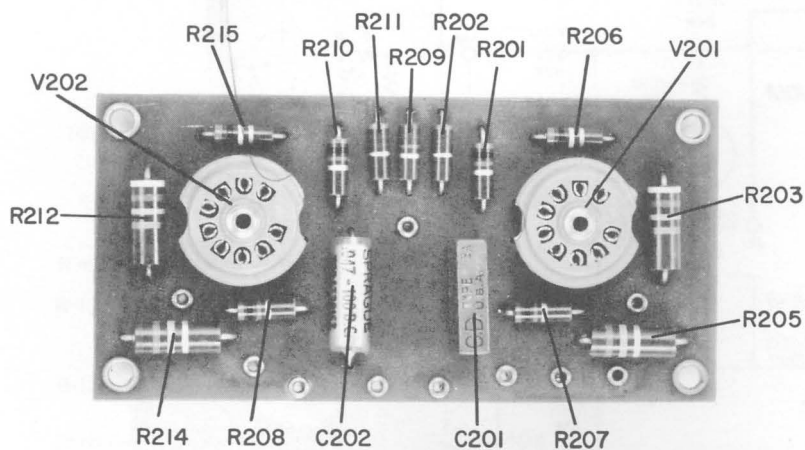
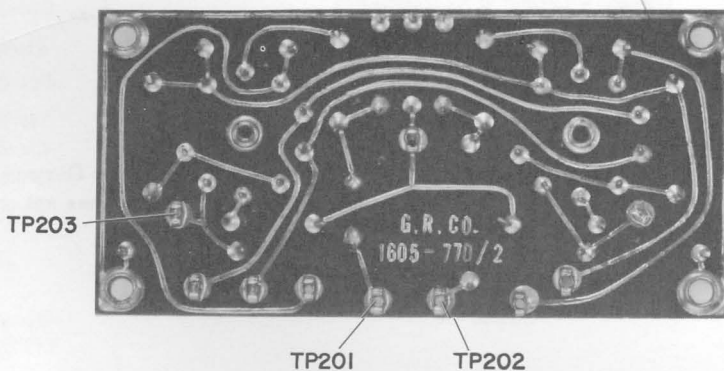

Figure 54.  
Top View, Reference  
Amplifier Circuit Board.

Figure 55.  
Bottom View, Reference  
Amplifier Circuit Board.



PARTS LIST

				GR No. (NOTE A★)					GR No. (NOTE A★)			
RESISTORS (Note B★)	R201	100	±10%	1/2 w	REC-20BF	R224	20	k	±10%	POSC-11		
	R202	1.5 M	±10%	1/2 w	REC-20BF	R225	20	k	±10%	POSC-11		
	R203	47 k	± 5%	1 w	REC-30BF	R226	63	k	± 1%	1 w	REF-75	
	R204					R227	20	k	±10%		POSC-11	
	R205	27	k	±10%	1 w	REC-30BF	R228	70	k	± 1%	1 w	REF-75
	R206	100	k	±10%	1/2 w	REC-20BF	R229	1	k	±10%		POSW-3
	R207	100		±10%	1/2 w	REC-20BF	R230	7.6	k	± 1%	1/2 w	REF-70
	R208	100		±10%	1/2 w	REC-20BF	R231	250		±10%		POSW-3
	R209	220		±10%	1/2 w	REC-20BF	R232	909		± 1%	1/8 w	REF-60
	R210	100		±10%	1/2 w	REC-20BF						
	R211	1.5 M		±10%	1/2 w	REC-20BF						
	R212	47	k	± 5%	1 w	REC-30BF						
	R214	27	k	±10%	1 w	REC-30BF						
	R215	100	k	±10%	1/2 w	REC-20BF						
		R221	500		±10%	POSW-3						
	R222	1	k	±10%	POSW-3							
	R223	2	k	±10%	POSW-3							
CAPACITORS (Note C★)	C201	0.0047	±10%	300dcwv	COM-5B							
	C202	0.047	±10%	100dcwv	COW-17							
	C203	10		250dcwv	COE-33							
	C204	200		12 dcwv	COE-6							
	C205	10 µf		250dcwv	COE-33							
	C211	0.001	± 5%	500dcwv	COM-20B							
	C212	0.018	± 1%	100dcwv	1605-210							
	C213	0.002	± 1%	500dcwv	COM-30E							
C214	0.0047	±10%	600dcwv	COL-71								

★ For NOTES refer to page 42.

# TYPE 1605-A IMPEDANCE COMPARATOR

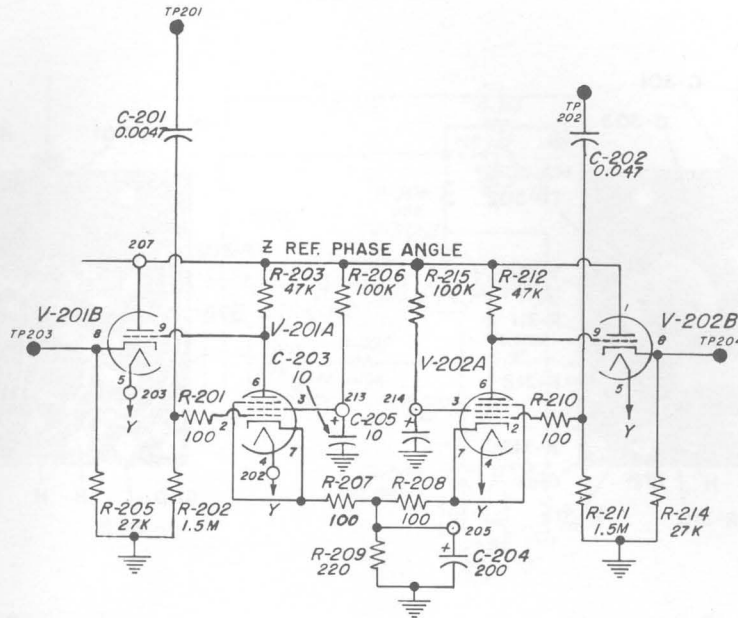

- KNOB CONTROL
- ⊗ SCREW DRIVER ADJUSTMENT

Figure 56.  
Reference Amplifier Circuit Diagram.

TABLE 7.3  
TEST VOLTAGES AND RESISTANCES

Switch Control and Settings:

FREQUENCY: 1 kc.  
Function: Any

CAL: for 1% calibration.  
Ranges: Any.

Meters: Refer to paragraph 7.5.  
Power off and plate supply grounded  
for resistance measurements.

TEST POINT or TUBE	PIN	FUNCTION	VOLTS		RES TO GND	TEST POINT or TUBE	PIN	FUNCTION	VOLTS		RES TO GND
			DC	AC(rms)					DC	AC(rms)	
TP201		Z Ref input	0	0.3	1 k(a)	V202 (6U8) θ Ref	1	Plate (B) B+2	230	0	0
TP202		θ Ref input	0	0.3	80 k(a)		2	Grid (A)	0*	0.3	1.5 M
TP203		Z Ref output	100	22	14 k		3	Screen (A)	100	0	47 k
TP204		θ Ref output	100	22	14 k		4	Heater	0	3.4(b)	0
V201 (6U8) Z Ref	1	Plate (B) B+2	230	0	0	5	Heater	0	2.9(b)	0	
	2	Grid (A)	0*	0.3	1.5 M	6	Plate (A)	100	22	47 k	
	3	Screen (A)	100	0	47 k	7	Cathode (A)	2.2	<0.1	320	
	4	Heater	0	3.4(b)	0	8	Cathode (B)	100	22	14 k	
	5	Heater	0	2.9(b)	0	9	Grid (B)	100	22	47 k	
	6	Plate (A)	100	22	47 k						
	7	Cathode (A)	2.2	<0.1	320						
	8	Cathode (B)	100	22	14 k						
	9	Grid (B)	100	22	47 k						

\* High impedance; use VTVM

(a) Depends on REF PHASE ANGLE adjustment and frequency setting. Values shown are approximate at 1 kc setting.

(b) Varies with line voltage.

GENERAL RADIO COMPANY

INPUT CIRCUIT

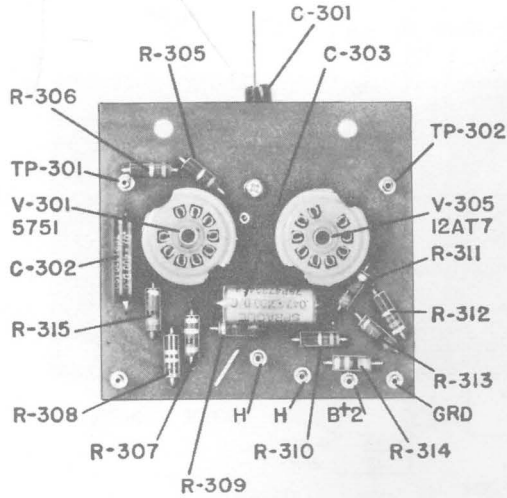

Figure 57.

Top View, Input Cathode Follower Circuit Board.

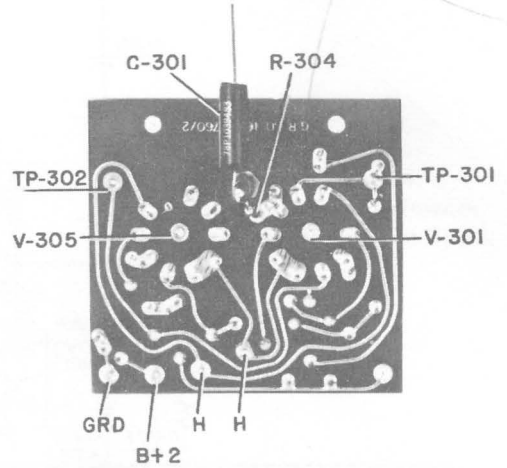

Figure 58.

Bottom View, Input Cathode Follower Circuit Board.

PARTS LIST

				GR No. (NOTE A)★					GR No. (NOTE A)★		
RESISTORS (Note B)★	R300	47	±5%	1/2 w	REC-20BF	R336	100	±10%	1/2 w	REC-20BF	
	R301	20 k	±1%	1/2 w	REF-70	R337	500 k	±10%		POSC-11	
	R302	100	±1%	1/2 w	REF-70	R338	1 M	±10%	1/2 w	REC-20BF	
	R303	6.8 k	±5%	1/2 w	REC-20BF	R339	10 M	±10%	1/2 w	REC-20BF	
	R304	50 k	±5%	1/8 w	REF-60	R340	100	±10%	1/2 w	REC-20BF	
	R305	5.6 M	±10%	1/2 w	REC-20BF	R343	1 M	±10%	1/2 w	REC-20BF	
	R306	2.7 k	±10%	1/2 w	REC-20BF	R344	390 k	±10%	1/2 w	REC-20BF	
	R307	100 k	±10%	1/2 w	REC-20BF	R351	25 k	±10%		POSC-11	
	R308	82 k	±10%	1/2 w	REC-20BF	R352	240 k	±5%	1/2 w	REC-20BF	
	R309	1 M	±10%	1/2 w	REC-20BF	R353	270 k	±10%	1/2 w	REC-20BF	
	R310	680	±10%	1/2 w	REC-20BF	R354	27 k	±10%	1 w	REC-30BF	
	R311	100	±10%	1/2 w	REC-20BF	R355	1 M	±10%	1/2 w	REC-20BF	
	R312	470	±10%	1/2 w	REC-20BF	R356	270 k	±10%	1/2 w	REC-20BF	
	R313	1 M	±10%	1/2 w	REC-20BF	CAPACITORS (Note C)★	C301	0.01	±10%	400dcwv	COW-25
	R314	10 k	±10%	1/2 w	REC-20BF		C302	0.01	±10%	400dcwv	COW-25
	R315	100	±10%	1/2 w	REC-20BF		C303	0.047	±10%	400dcwv	COW-25
	R316	1 M	±10%	1/2 w	REC-20BF		C304	10		250dcwv	COE-33
	R317	4.7 M	±10%	1/2 w	REC-20BF		C305	1	±10%	200dcwv	COW-16
	R321	100	±10%	1/2 w	REC-20BF		C306	0.033	±10%	200dcwv	COP-24
	R322	1 M	±10%	1/2 w	REC-20BF		C307	0.0047	±10%	500dcwv	COC-63
	R323	330	±5%	1/2 w	REC-20BF		C311	0.047	±10%	100dcwv	COW-17
	R324	33 k	±10%	1 w	REC-30BF		C312	0.047	±10%	400dcwv	COW-25
	R325	100	±10%	1/2 w	REC-20BF		C313	0.047	±10%	100dcwv	COW-17
	R326	1 M	±10%	1/2 w	REC-20BF		C314	1.5-5.0 μmf			COA-26
	R327	27 k	±5%	2 w	REC-41BF		C315	0.047	±10%	400dcwv	COW-25
	R328	5 k	±10%		POSW-3		C316	0.047	±10%	400dcwv	COW-25
	R329	30 k	±5%	2 w	REC-41BF		C317	0.22	±10%	100dcwv	COW-17
	R330	330	±5%	1/2 w	REC-20BF		C318	0.22	±10%	100dcwv	COW-17
	R331	10 k	±10%	1/2 w	REC-20BF		C319	0.01	±20%	500dcwv	COC-60
	R332	100	±10%	1/2 w	REC-20BF		C320	0.01	±20%	500dcwv	COC-60
	R333	1 M	±10%	1/2 w	REC-20BF	D301	CRYSTAL DIODE (1N645)			2RE D-1016	
	R334	10 M	±10%	1/2 w	REC-20BF	D302	CRYSTAL DIODE (1N645)			2RE D-1016	
	R335	1 M	±10%	1/2 w	REC-20BF	REL301	RELAY			1605-40	

★ For NOTES refer to page 42.

TYPE 1605-A IMPEDANCE COMPARATOR

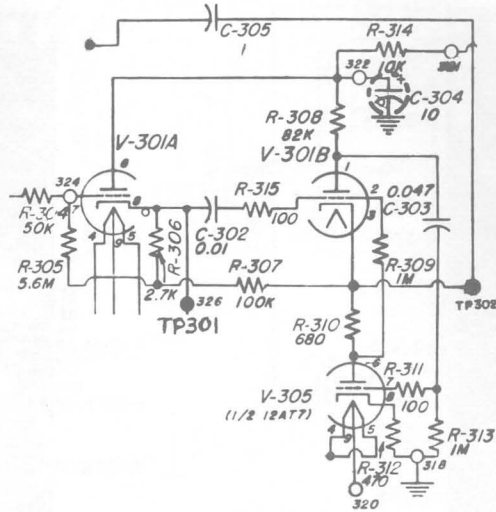

Figure 59.  
Input Cathode Follower Circuit Diagram.

(Components enclosed by broken lines not on etched board.)

TABLE 7.4  
TEST VOLTAGES AND RESISTANCES

Switch and Control Settings:

FREQUENCY: 1 kc. CAL: for 1% calibration. Meters: Refer to paragraph 7.5.  
Function: CAL Ranges: Any Power off and plate supply grounded for resistance measurements.

TEST POINT or TUBE	PIN	FUNCTION	VOLTS		RES TO GND	TEST POINT or TUBE	PIN	FUNCTION	VOLTS		RES TO GND
			DC	AC(rms)					DC	AC(rms)	
TP301		Signal output	120	0		V305 (12AT7)	4	Heater	0	2.9(b)	—
TP302		Guard output	70	0			6	Plate	69	0	
V301 (5751)	1	Plate (B)	165	0	92 k		7	Grid	0*	0	1 M
	2	Grid (B)	69*(a)	0			8	Cathode	0.7	0	470
	3	Cathode (B)	70	0			9	Heater	0	3.4(b)	—
	4	Heater	0	2.9	0						
	5	Heater	0	2.9	0						
	6	Plate (A)	235	0	10 k						
	7	Grid (A)	119*(a)	0							
	8	Cathode (A)	120	0							
	9	Heater	0	3.4	0						

\* High impedance: use VTVM

(a) Very high input impedance (especially pin 7, V301).

(b) Depends on line voltage.



SIGNAL AMPLIFIER

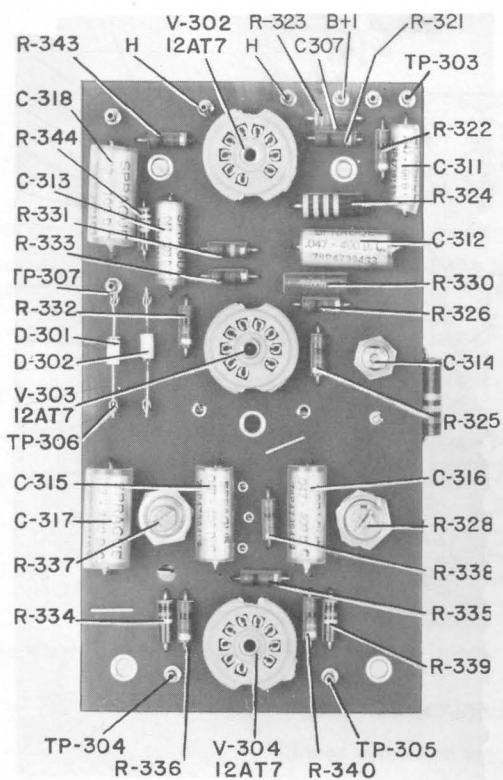

Figure 60.  
Top View, Signal Amplifier Circuit Board.

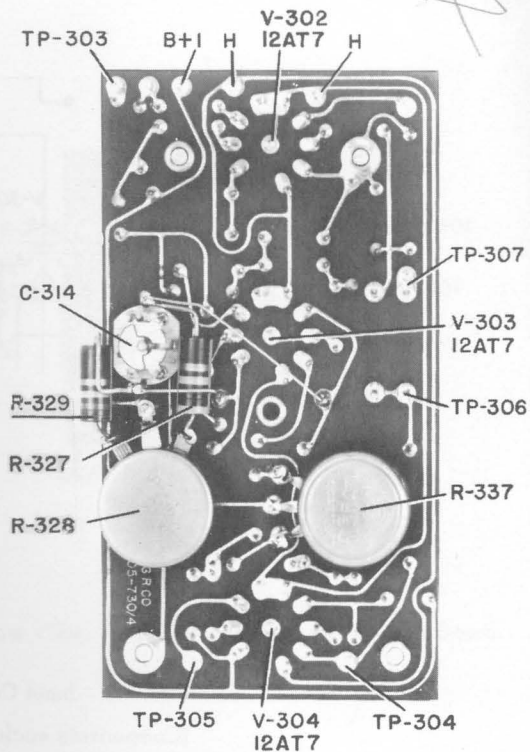

Figure 61.  
Bottom View, Signal Amplifier Circuit Board.

FOR PARTS LISTING REFER TO PAGE 34.

# TYPE 1605-A IMPEDANCE COMPARATOR

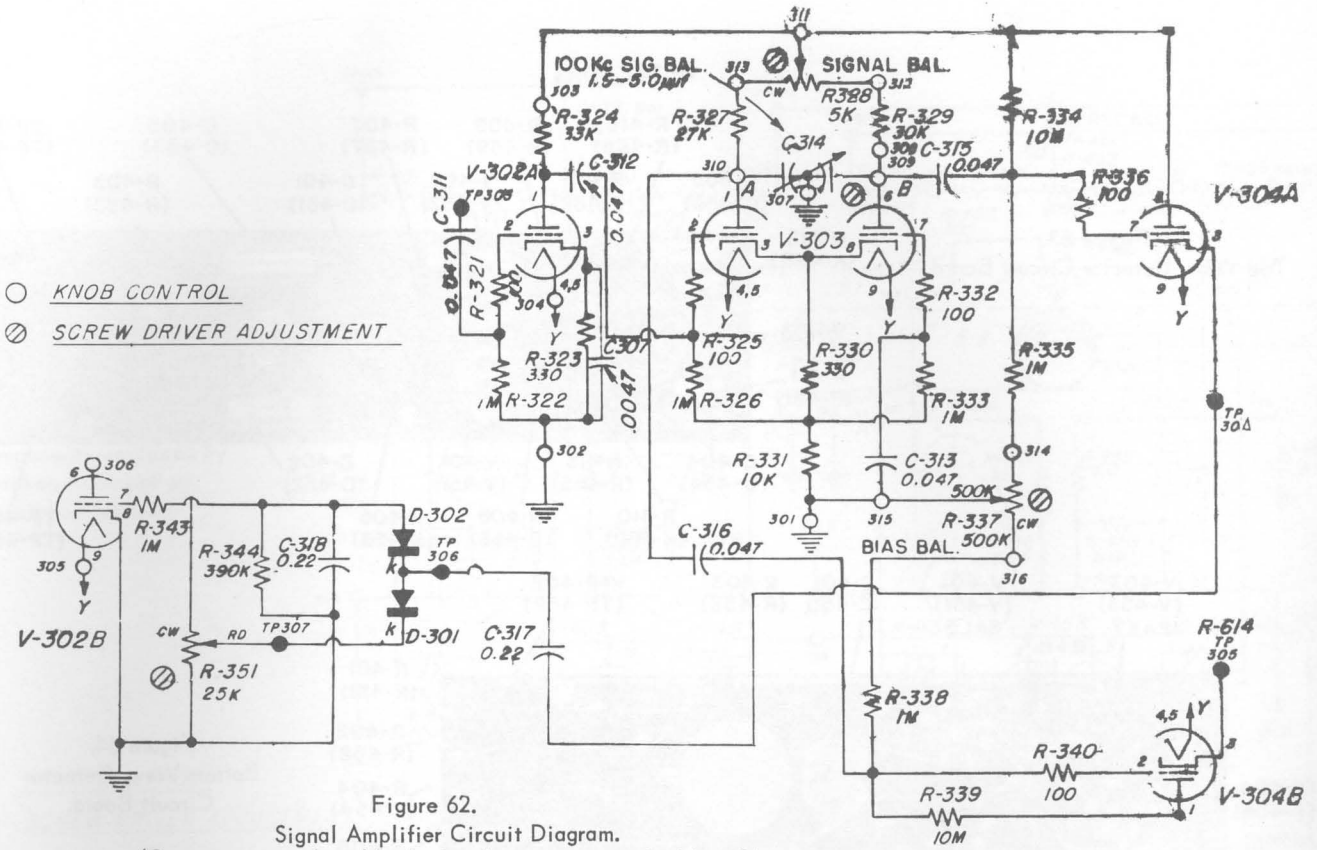

TABLE 7.5  
TEST VOLTAGES AND RESISTANCES

Switch and Control Settings:

FREQUENCY: 1 kc.  
Function: CAL.

CAL: for 1% calibration.  
Ranges: Any

Meters: Refer to paragraph 7.5.  
Power off and plate supply grounded  
for resistance measurements.

TEST POINT or TUBE	PIN	FUNCTION	VOLTS		RES TO GND	TEST POINT or TUBE	PIN	FUNCTION	VOLTS		RES TO GND
			DC	AC(rms)					DC	AC(rms)	
TP303		Input	0	0	100(c)	V303 (12AT7)	1	Plate (A)	170	0.7	29 k
TP304		Output	30	0.7(a)	6 k		2	Grid (A)	0*	0.1	1M
TP305		Output	30	0.7(a)	6 k		3	Cathode (A)	50	0.1	10 k
TP306		Signal to relay rectifier	0-22(b)	0.7(a)	0-22 k(b)		4	Heater	0	3.4	0
		Relay adjustment	0				5	Heater	0	3.4	0
		bias	0-22(b)	0	0-22 k(b)		6	Plate (B)	170	0.7	32 k
TP307		Relay adjustment	0-22(b)	0	0-22 k(b)		7	Grid (B)	0*	0.1	1M
		bias	0-22(b)	0	0-22 k(b)		8	Cathode (B)	50	0.1	10 k
			0-22(b)	0	0-22 k(b)		9	Heater	0	2.9	0
V302 (12AT7)	1	Plate (A)	120	0.1	33 k	V304 (12AT7)	1	Plate (B) B+2	250	0	0
	2	Grid (A)	0*	0.1	1 M		2	Grid (B)	28	0.7	1.2 M
	3	Cathode (A)	1.3	0.1	330		3	Cathode (B)	30	0.7	6 k
	4	Heater	0	2.9	0		4	Heater	0	2.9	0
	5	Heater	0	2.9	0		5	Heater	0	2.9	0
	6	Plate (B) to relay	95	0	30 k		6	Plate (A)	250	0	0
	7	Grid (B)	*	0	1 M		7	Grid (A)	28	0.7	1.2 M
	8	Cathode (B)	0	0	0		8	Cathode (A)	30	0.7	6 k
	9	Heater	0	3.4	0		9	Heater	0	3.4	0

\* High impedance; use VTVM

(a) Small signal present here, even with input at ZERO, due to reference signal.

(b) Varies with relay adjustment.

(c) Depends on function switch setting.

GENERAL RADIO COMPANY

Figure 63.  
Top View, Detector Circuit Board.

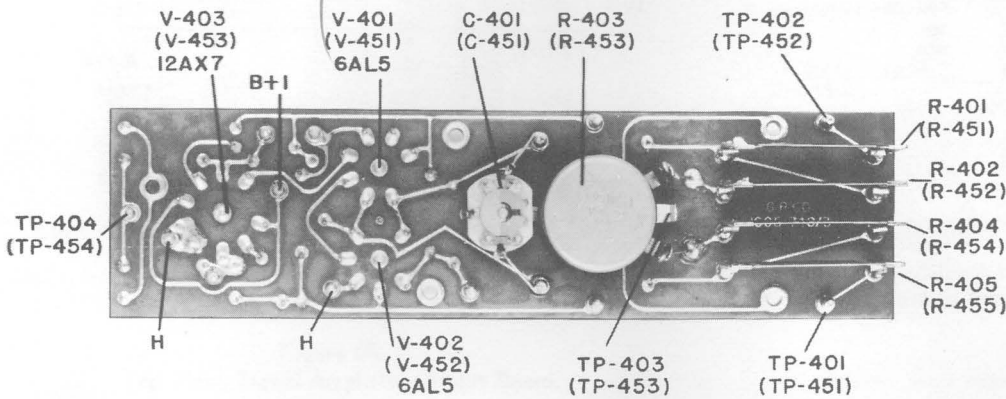
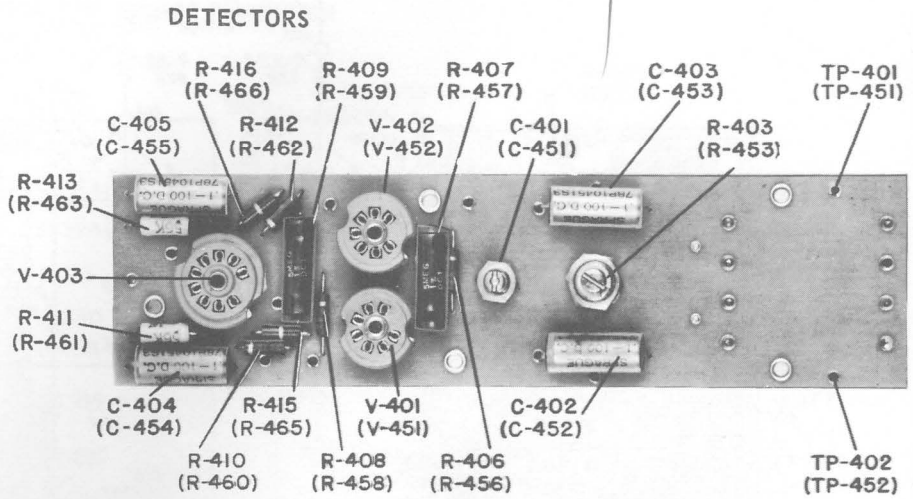

Figure 64.  
Bottom View, Detector  
Circuit Board.

PARTS LIST

				GR No. (NOTE A)★					GR No. (NOTE A)★			
RESISTORS (Note B)★	R401	30 k	±1/4%	510-390-2	RESISTORS (Note B)★	R458	5.1 M	± 5%	1/2 w	REC-20BF		
	R402	30 k	±1/4%	510-390-2		R459	5 M	± 1%	1/2 w	REF-70		
	R403	500	±10%	POSW-3		R460	100	±10%	1/2 w	REC-20BF		
	R404	30 k	±1/4%	510-390-2		R461	56 k	± 1%	1/4 w	REF-65		
	R405	30 k	±1/4%	510-390-2		R462	100	±10%	1/2 w	REC-20BF		
	R406	5.1 M	± 5%	1/2 w		REC-20BF	R463	56 k	± 1%	1/4 w	REF-65	
	R407	5 M	± 1%	1/2 w		REF-70	R464	5 k	±10%		POSW-3	
	R408	5.1 M	± 5%	1/2 w		REC-20BF	R465	2.2 M	±10%	1/2 w	REC-20BF	
	R409	5 M	± 1%	1/2 w		REF-70	R466	2.2 M	±10%	1/2 w	REC-20BF	
	R410	100	±10%	1/2 w		REC-20BF	CAPACITORS (Note C)★	C401	1.5-5.0μf			COA-26
	R411	56 k	± 1%	1/4 w		REF-65		C402	0.1	± 5%	100dcwv	COW-17
	R412	100	±10%	1/2 w		REC-20BF		C403	0.1	± 5%	100dcwv	COW-17
	R413	56 k	± 1%	1/4 w		REF-65		C404	0.1	± 5%	100dcwv	COW-17
	R414	2.4 k	± 1%	1/2 w		REF-70		C405	0.1	± 5%	100dcwv	COW-17
	R415	2.2 M	±10%	1/2 w		REC-20BF		C451	1.5-5.0μf			COA-26
	R416	2.2 M	±10%	1/2 w		REC-20BF		C452	0.1	± 5%	100dcwv	COW-17
R451	30 k	±1/4%		510-390-2	C453	0.1		± 5%	100dcwv	COW-17		
R452	30 k	±1/4%		510-390-2	C454	0.1		± 5%	100dcwv	COW-17		
R453	500	±10%		POSW-3	C455	0.1		± 5%	100dcwv	COW-17		
R454	30 k	±1/4%		510-390-2	M401	METER, 200μa			MEDS-121			
R455	30 k	±1/4%		510-390-2	M451	METER, 200μa			MEDS-121			
R456	5.1 M	± 5%	1/2 w	REC-20BF	SO401	SOCKET			CDMS-1262-6			
R457	5 M	± 1%	1/2 w	REF-70								

★ For NOTES refer to page 42.

# TYPE 1605-A IMPEDANCE COMPARATOR

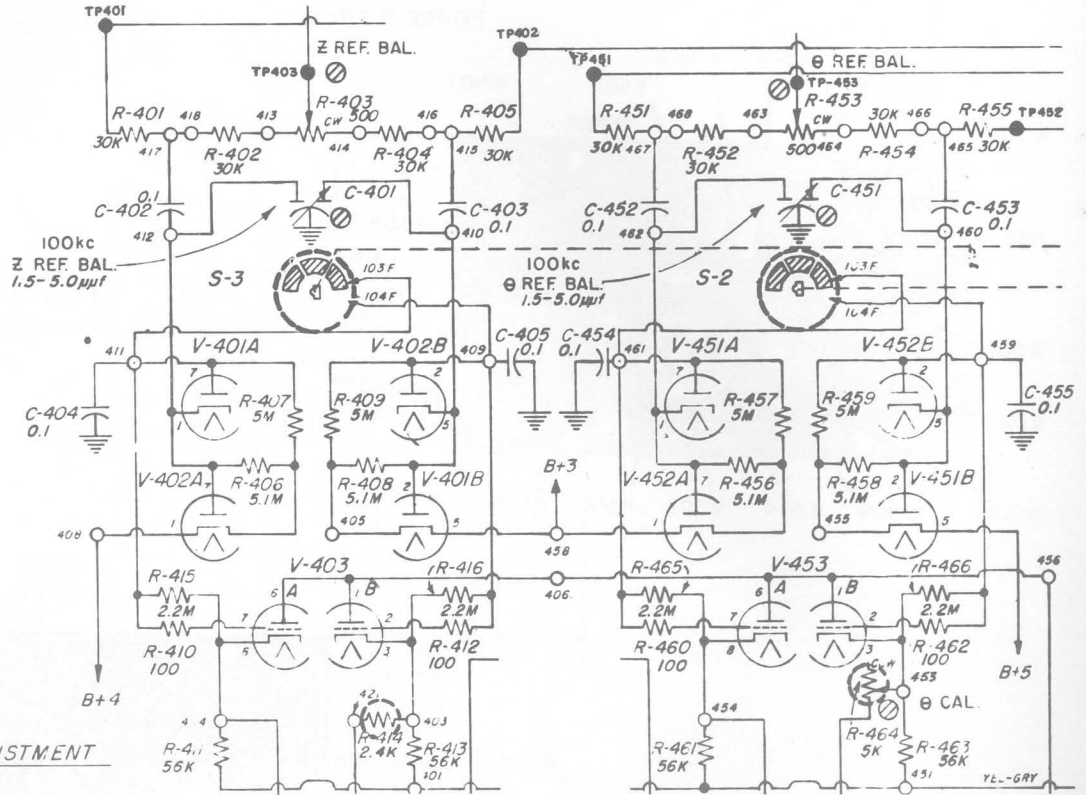

Figure 65.  
Detector Circuit Diagram.  
(Components enclosed by  
broken lines not on  
etched board.)

- KNOB CONTROL
- ◌ SCREW DRIVER ADJUSTMENT

### NOTE

There are two detector assemblies: one for  $\Delta Z$  and one for  $\Delta \theta$ . The only difference between them in circuitry is a resistor (not on the board) that is variable in the  $\Delta \theta$  circuit (R464) and fixed in the  $\Delta Z$  circuit (R414). Part numbers of components of the  $\Delta \theta$  detector are greater by 50 than the numbers of corresponding components on the  $\Delta Z$  detector.

TABLE 7.6  
TEST VOLTAGES AND RESISTANCES

Switch and Control Settings:

FREQUENCY: 1 kc. CAL: for 1% calibration. Meters: Refer to paragraph 7.5.  
Function: ZERO. Ranges: 1%, 0.01 radian. Power off and plate supply grounded for resistance measurements.

TEST POINT or TUBE	PIN	FUNCTION	VOLTS		RES TO GND	TEST POINT or TUBE	PIN	FUNCTION	VOLTS		RES TO GND
			DC	AC(rms)					DC	AC(rms)	
TP401		Signal input	14(a)	0.9(a)	6 k	V402	1	Cathode (A)	65	0	13 k
TP402		Signal input	14(a)	0.9(a)	6 k	V452	2	Anode (B)	35*	0	1.8 M
TP403		Ref input	100	22	14 k	(6AL5)	3	Heater	0	18.9	8
TP404		Ground (to relay)	0(b)	0	0		4	Heater	0	18.9	5 M
							5	Cathode	50*	11	5 M
							7	Anode	50*	11	5 M
V401	1	Cathode (A)	50*	11	5 M		V403 V453 (12AX7)	1	Plate B + 1	250	0
V451	2	Anode (B)	50*	11	5 M	2		Grid	35*	0	1.8 M
(6AL5)	3	Heater	0	12.6	6	3		Cathode	37(b)	0	650 k (c)
	4	Heater	0	6.3	4	4		Heater	0	0	0
	5	Cathode (B)	65	0	13 k	5		Heater	0	0	0
	7	Anode (A)	35*	0	1.8 M	6		Plate B + 1	250	0	0
						7		Grid	35*	0	1.8 M
						8		Cathode	37(b)	0	650 k (c)
						9		Heater	0	6.3	4

\* High impedance; use VTVM

(a) Depends on range setting.

(b) Potential rises to over 100v when OFF SCALE light is on.

(c) Lower impedance with instrument turned on and relay closed.



GENERAL RADIO COMPANY

POWER SUPPLY

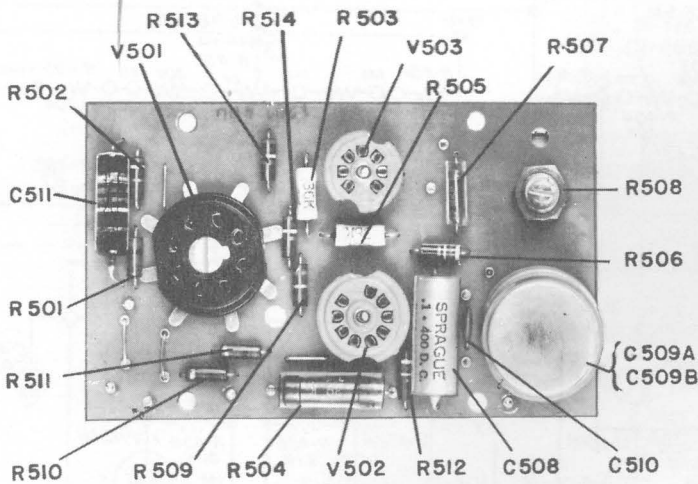

Figure 66.  
Top View, Power Supply Circuit Board.

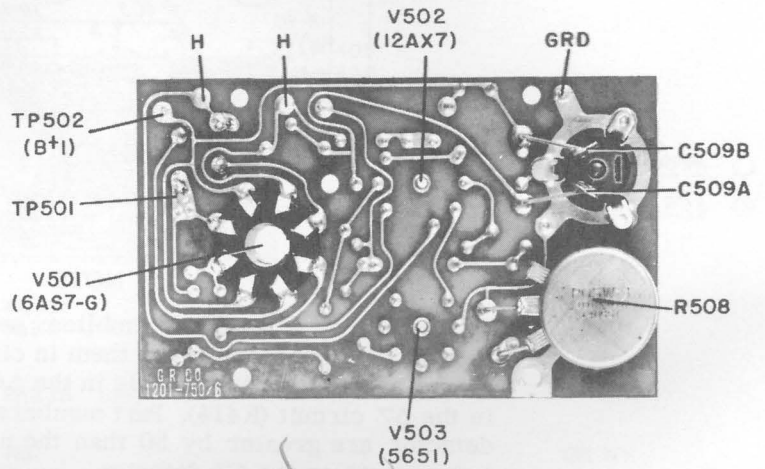

Figure 67.  
Bottom View, Power Supply Circuit Board.

PARTS LIST

		GR No. (NOTE A)★				GR No. (NOTE A)★			
RESISTORS (Note B)★	R501	1 M	±10%	1/2 w	REC-20BF	C501	100	450dcwv	COE-10
	R502	2.4 M	± 5%	1/2 w	REC-20BF	C502	100	450dcwv	COE-10
	R503	36 k	± 1%	1/4 w	REF-65	C503	50	450dcwv	COE-10
	R504	26 k	± 1%	1 w	REF-75	C504	25	450dcwv	
	R505	36 k	± 1%	1/4 w	REF-65	C505	25	450dcwv	
	R506	470 k	± 5%	1/2 w	REC-20BF	C506	0.01	±10% 600dcwv	COL-71
	R507	39 k	± 1%	1/4 w	REF-65	C507	0.01	±10% 600dcwv	COL-71
	R508	10 k	±10%		POSW-3	C508	0.1	±10% 400dcwv	COW-25
	R509	5.6 M	±10%	1/2 w	REC-20BF	C509A	10	450dcwv	COE-5
	R510	100	±10%	1/2 w	REC-20BF	C509B	10	450dcwv	
	R511	100	±10%	1/2 w	REC-20BF	C510	0.001	±20% 500dcwv	COC-60
	R512	470 k	± 5%	1/2 w	REC-20BF	C511	0.0047	±10% 600dcwv	COL-71
	R513	620 k	± 5%	1/2 w	REC-20BF				
	R514	120 k	± 5%	1/2 w	REC-20BF				
	R521	47 k	±10%	1 w	REC-30BF	PL501	INPUT PLUG		ZCDPP-10
	R522	1 k	±10%		POSW-3	RX501	SILICON RECTIFIER (1N3254)		2RE-1002
	R523	1 k	±10%		POSW-3	RX502	SILICON RECTIFIER (1N3254)		2RE-1002
	R524	300	± 5%	1/2 w	REC-20BF	T501	TRANSFORMER		365-474
	R525	300	± 5%	1/2 w	REC-20BF				
	R526	18 k	±10%	1/2 w	REC-20BF				
	R527	470	±10%	2 w	REC-41BF				
	R528	27	± 5%	5 w	REPO-43				
	R529	6.8	±10%	1/2 w	REW-3C				

★For NOTES refer to page 42.

# TYPE 1605-A IMPEDANCE COMPARATOR

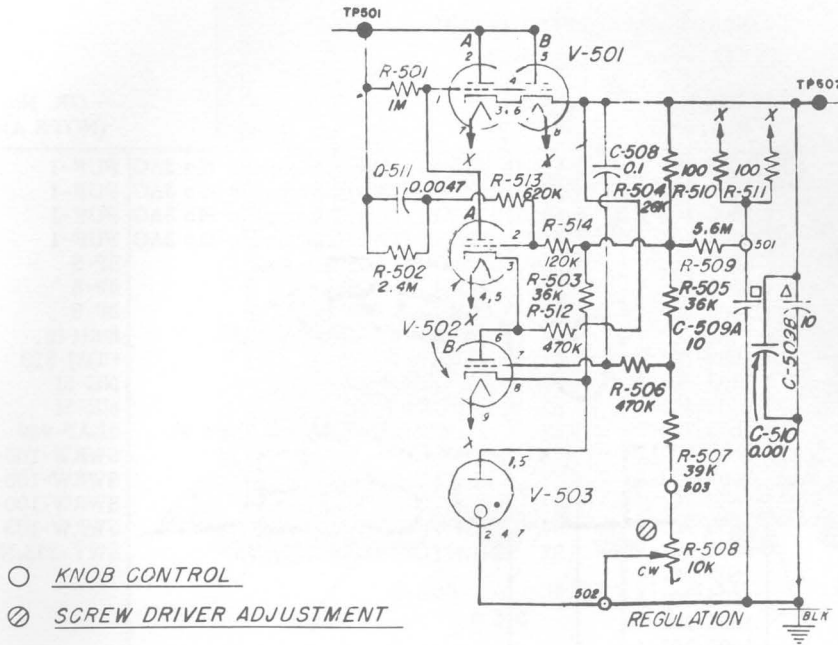

Figure 68.  
Power Supply Circuit Diagram.

TABLE 7.7  
TEST VOLTAGES AND RESISTANCES

Switch and Control Settings:

Panel Controls: Any

Meters: Refer to paragraph 7.5.

Power off and plate supply grounded  
for resistance measurements.

TEST POINT or TUBE	PIN	FUNCTION	VOLTS		RES TO GND	TEST POINT or TUBE	PIN	FUNCTION	VOLTS		RES TO GND
			DC	AC(rms)					DC	AC(rms)	
TP501		Input (unregulated)	325(a)	3(b)	0(d)	V502 (12AX7)	1	Plate	220	1.5(b)	1 M
TP502		Output (regulated)	250(c)	0	0(d)		2	Grid	150	0.6(b)	120 k
							3	Cathode	150	0.8(b)	470 k
							4	Heater	150	3.1(a)	5.6 M
							5	Heater	150	3.1(a)	5.6 M
							6	Plate	150	0.8(b)	470 k
							7	Grid	83	0	500 k
							8	Cathode (to V503, pins 1,5)	83	0	50 k
							9	Heater	150	3.1(a)	5.6 M
						V503 (5651)	1,5	Anode	83	0	50 k
							2,4,7	Cathode	0	0	0

- (a) Depends on line voltage.
- (b) Ripple, nonsinusoidal.
- (c) Set to 250 v (paragraph 7.3.1).
- (d) Grounded for measurement (paragraph 7.5).

GENERAL RADIO COMPANY

RANGE ATTENUATOR COMPONENTS

		GR No. (NOTE A)★		GR. No. (NOTE A)★
RESISTORS (Note B)★	R601	2.325 k ±1/4%	1605-202	F501 FUSE, (115v) 1.6 amp Slo-Blo 3AG FUF-1
	R602	2.325 k ±1/4%	1605-202	F501 FUSE, (230v) 0.8 amp Slo-Blo 3AG FUF-1
	R603	2.325 k ±1/4%	1605-202	F502 FUSE, (115v) 1.6 amp Slo-Blo 3AG FUF-1
	R604	2.325 k ±1/4%	1605-202	F502 FUSE, (230v) 0.8 amp Slo-Blo 3AG FUF-1
	R610	33 k ±10%	REC-20BF	J1 BINDING POST BP-5
	R611	8.13k ±1/4%	1605-203	J2 BINDING POST BP-5
	R612	8.13k ±1/4%	1605-203	J3 BINDING POST BP-5
	R613	8.13k ±1/4%	1605-203	J4 JACK, Type 874 Coaxial Built in
	R614	8.13k ±1/4%	1605-203	J5 JACK CDSJ-820
	R621	2.60k ±1/4%	1605-202-2	P1 PILOT LAMP NE-51
	R622	2.60k ±1/4%	1605-202-2	P2 PILOT LAMP NE-51
	R623	2.60k ±1/4%	1605-202-2	P3 PILOT LAMP, Mazda Type 44 2LAP-939
	R624	2.60k ±1/4%	1605-202-2	S1 SWITCH SWRW-100-2
	R631	797 ±1/4%	1605-202-3	S2 SWITCH SWRW-100-2
	R632	797 ±1/4%	1605-202-3	S3 SWITCH SWRW-100-2
	R633	797 ±1/4%	1605-202-3	S4 SWITCH SWRW-103
	R634	797 ±1/4%	1605-202-3	S5 SWITCH SWT-333,NP
	R641	363 ±1/4%	1605-202-4	
	R642	363 ±1/4%	1605-202-4	
	R643	363 ±1/4%	1605-202-4	
R644	363 ±1/4%	1605-202-4		

★ NOTES

(A) Type designations for resistors and capacitors are as follows:

- |                               |                                   |
|-------------------------------|-----------------------------------|
| COA - Capacitor, air          | COW - Capacitor, wax              |
| COC - Capacitor, ceramic      | POSC - Potentiometer, composition |
| COE - Capacitor, electrolytic | POSW - Potentiometer, wire-wound  |
| COL - Capacitor, oil          | REC - Resistor, composition       |
| COM - Capacitor, mica         | REF - Resistor, film              |
| COP - Capacitor, plastic      | REW - Resistor, wire-wound        |

(B) All resistances are in ohms, unless otherwise indicated by k (kilohms) or M (megohms).

(C) All capacitances are in microfarads, unless otherwise indicated by μf (micromicrofarads).

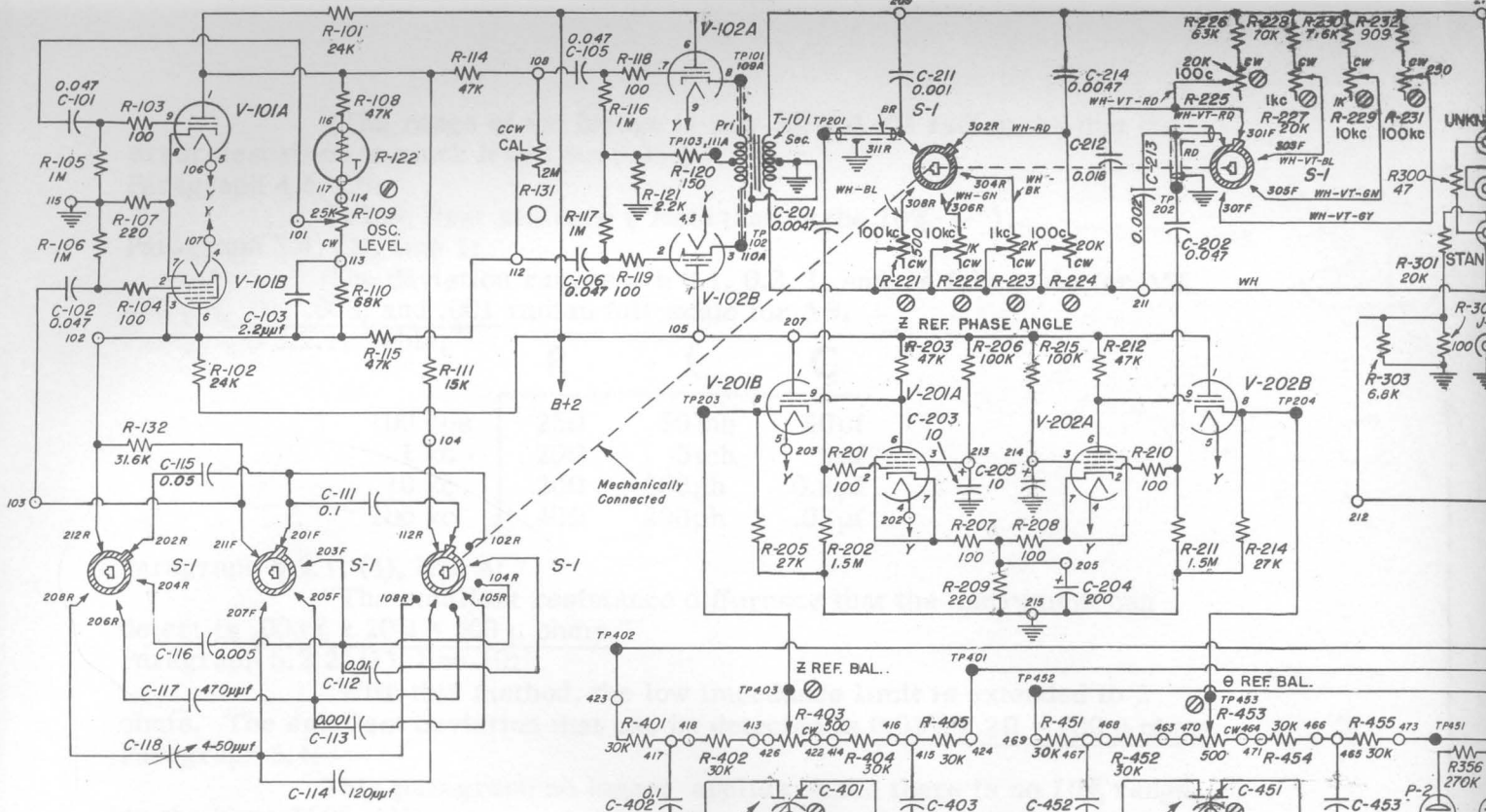

FREQUENCY  
1kc 10kc  
100kc ← S-1 → 100kc  
ENGRAVING

TUBES

V-101	6U8	V-401	6AL5
V-102	12AT7	V-402	6AL5
		V-403	12AX7
		V-451	6AL5
		V-452	6AL5
V-201	6U8	V-453	12AX7
V-202	6U8		
V-301	5751	V-501	6AS7G
V-302	12AT7	V-502	12AX7
V-303	12AT7	V-503	5651
V-304	12AT7	V-504	(AMPERITE) 3A10
V-305	12AT7		

NOTE FOR T-501  
FOR 115V OPERATION CONNECT  
#1 TO #3 & #2 TO #4  
FOR 230V OPERATION CONNECT  
#2 TO #3

INPUT  
115-230V  
50-60~

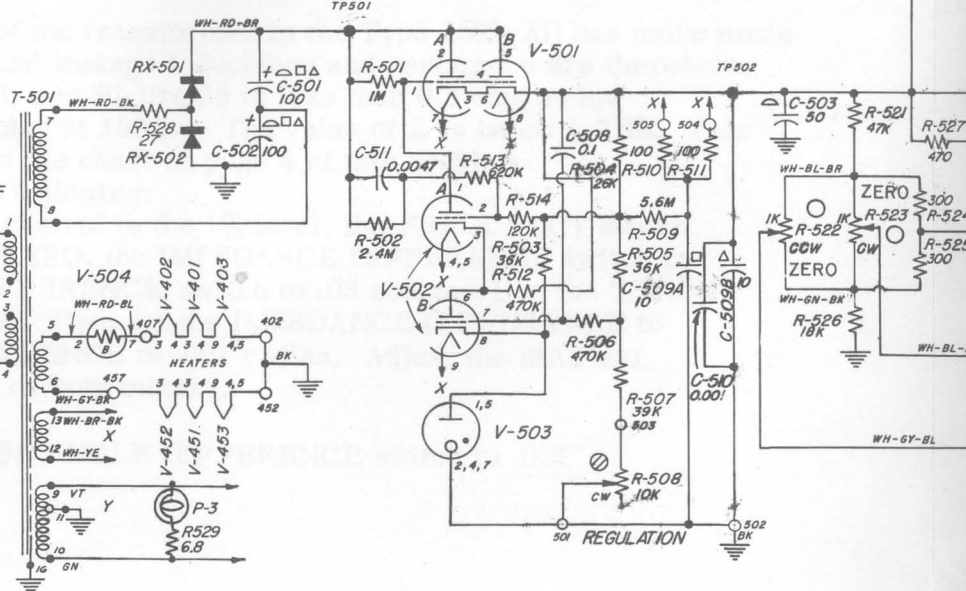
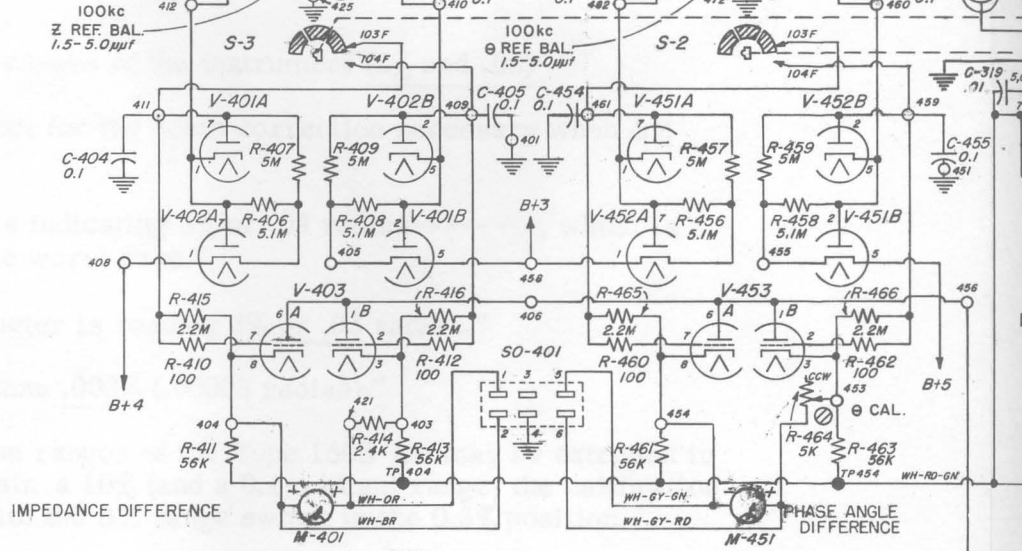
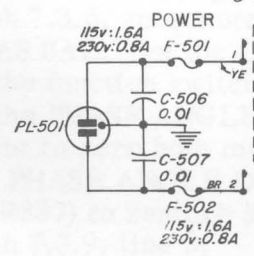



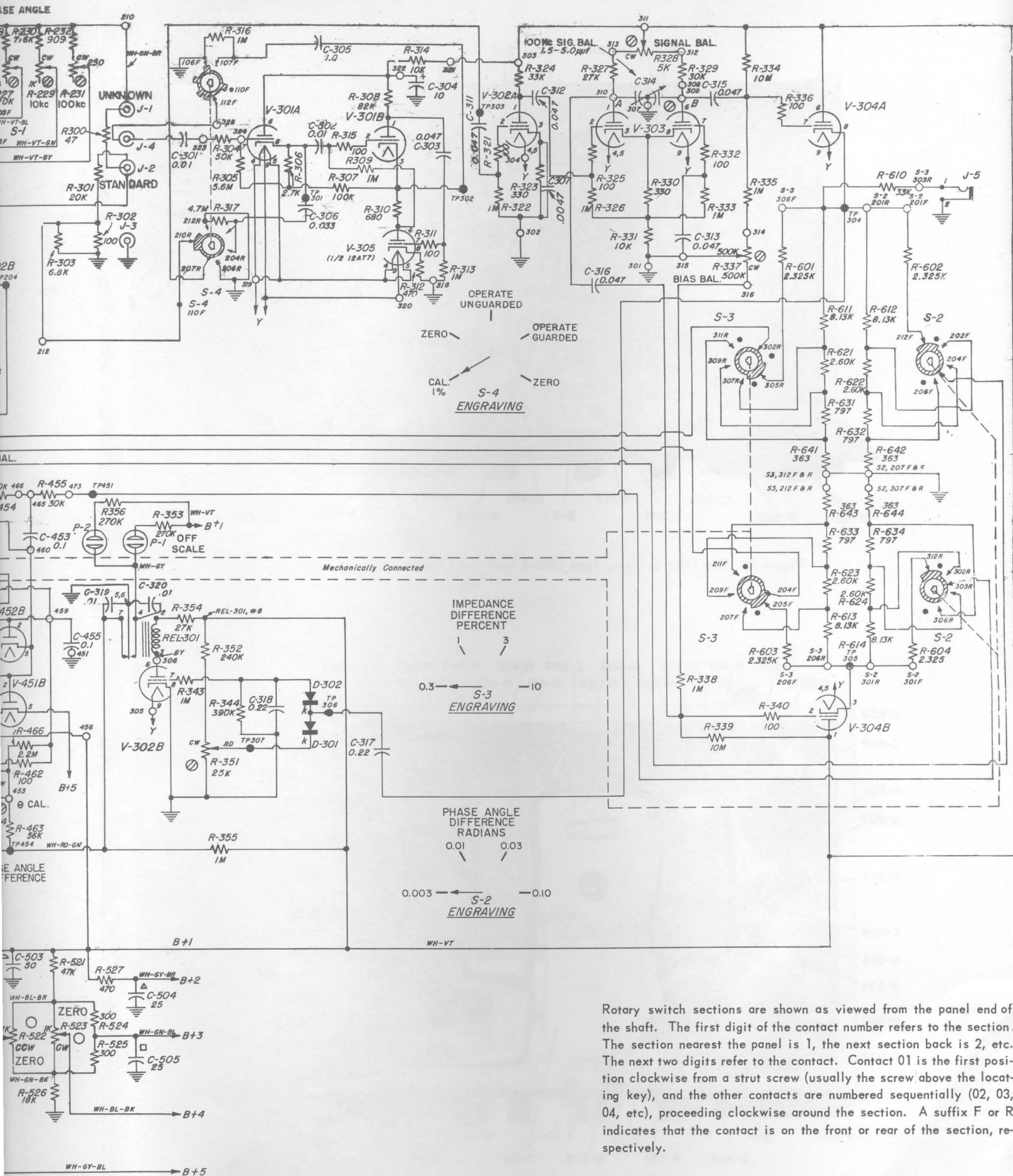

Rotary switch sections are shown as viewed from the panel end of the shaft. The first digit of the contact number refers to the section. The section nearest the panel is 1, the next section back is 2, etc. The next two digits refer to the contact. Contact 01 is the first position clockwise from a strut screw (usually the screw above the locating key), and the other contacts are numbered sequentially (02, 03, 04, etc), proceeding clockwise around the section. A suffix F or R indicates that the contact is on the front or rear of the section, respectively.

Figure 69. Detailed Schematic Diagram, Type 1605-A Impedance Comparator.

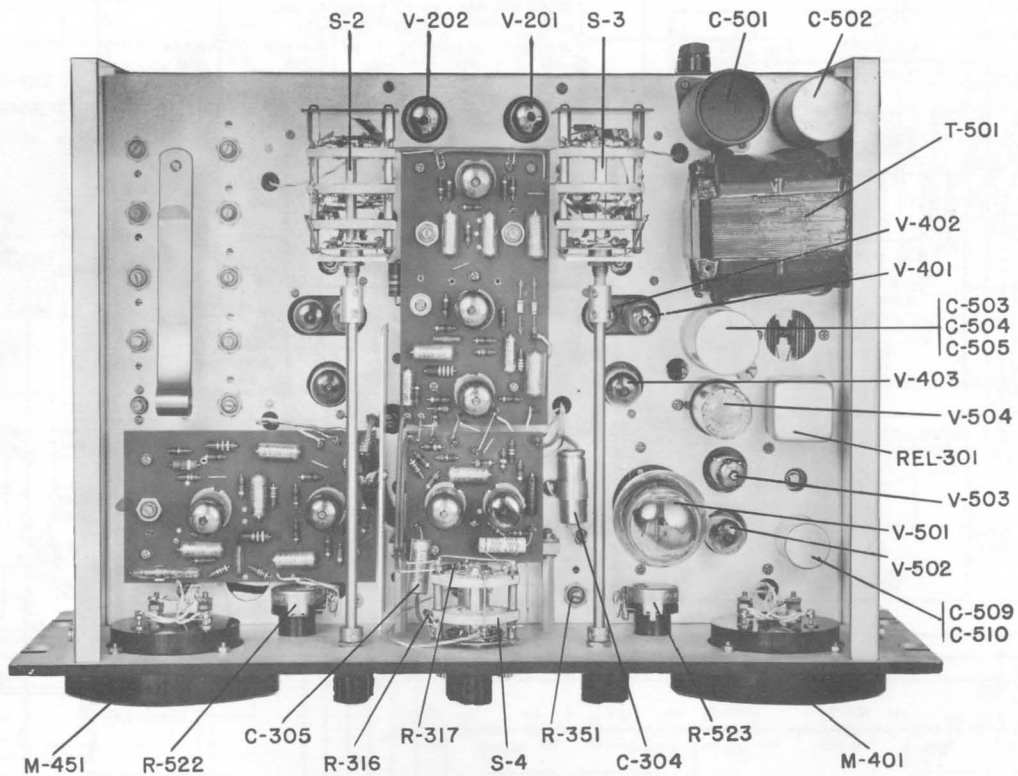

Figure 70. Top Interior View, Type 1605-A Impedance Comparator.

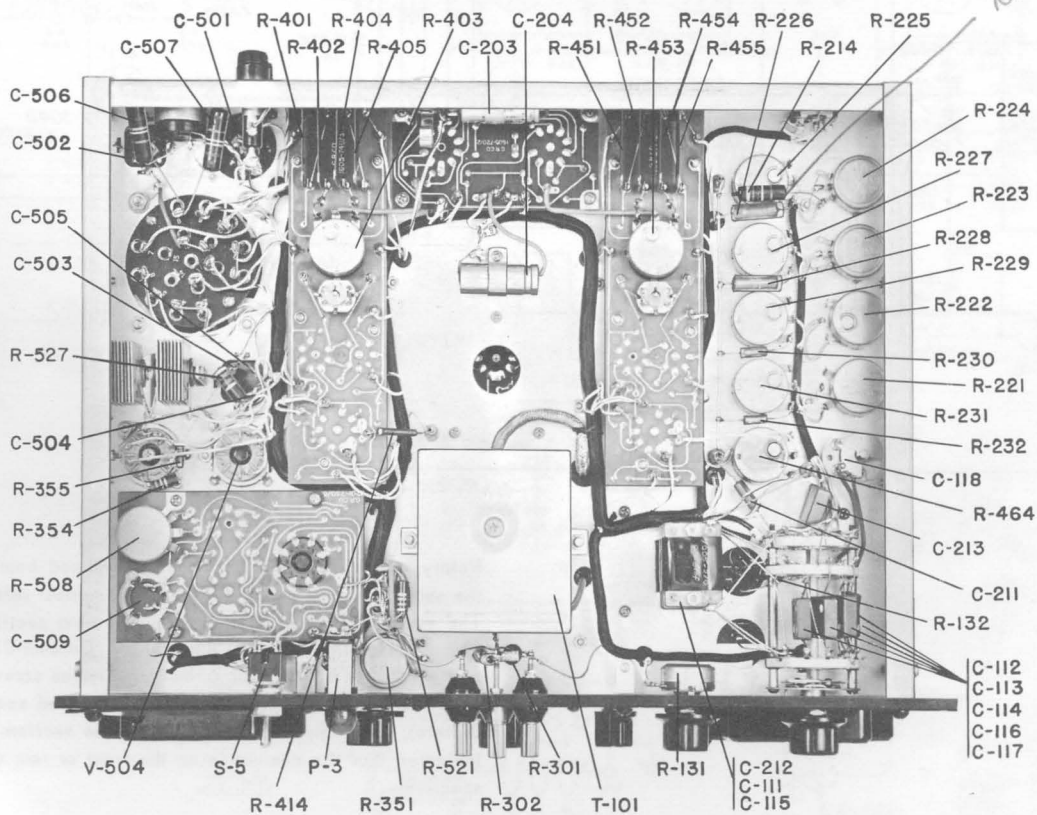

Figure 71. Bottom Interior View, Type 1605-A Impedance Comparator.

Since the primary voltage remains the same, the reduction of primary turns causes an increase in the voltage across the bridge,  $E_b$ . The expression for the output voltage is

$$E_o = \frac{Z_{u1} - Z_s}{Z_u + Z_s} E_b$$

Therefore, if  $E_b$  is increased, the deviation may be smaller for the same output voltage.

The volt-amperes supplied to the unknown is  $\frac{(E_b)^2}{|Z_u|}$

Since the power available from the oscillator is unchanged, the lower limit of the impedance range is increased by the square of the factor by which the voltage was increased. Thus the lower limits on R and L are increased, and the upper limit on C is reduced by a factor of 10 (the actual voltage change is 10 to 1).

The only other circuit change is the addition of several resistors used to reduce the voltage in the reference amplifier. The added resistors are shown in Figure 2.

Figure 2.

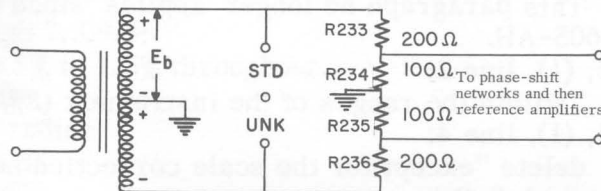

These resistors divide the increased bridge voltage back to its former value so that the networks that follow work in the same dynamic range as they do in the standard instrument.

#### 4. CORRECTIONS TO BE MADE IN THE 1605-A INSTRUCTION BOOK TO ADAPT FOR 1605-AH. In the following list of revisions, underlined words or numbers are correct for the Type 1605-AH. Paragraph 1.1, (2), line 8:

"---measurements to .003% and .00003 radian,---"

Paragraph 2.3, (2), line 3;

"If  $\Delta\theta$  is within 0.1 radian, this approximation---"

(The range of the bridge is now  $\Delta\theta = .03$ , and within this range the error described is much less than 0.25%.)

Paragraph 2.3, (3), line 6:

There is no 10% range, so that the error described does not occur.

Paragraph 2.3, (4), line 2:

"if both  $\Delta Z$  and  $\Delta\theta$  are within 10% and 0.1 radian respectively, this expression reduces to---"

## APPENDIX A

# DIFFERENCE DATA

## TYPE 1605-AH IMPEDANCE COMPARATOR

1. DESCRIPTION. The Type 1605-AH Impedance Comparator is a modified version of the Type 1605-A. The principal difference is a 3-to-1 increase in sensitivity due to higher voltage applied to the bridge circuit. It is thus possible to detect impedance differences of .003 percent (30 ppm) and phase-angle differences of .00003 radian, so that very precise measurements can be made.

Although many of the specifications have been changed, the general operating procedure is the same as that for the standard model. Sections of the Type 1605-A Operating Instructions that should be corrected to apply to the Type 1605-AH are listed in paragraph 4.

2. SPECIFICATIONS. The specifications for the Type 1605-AH are given, along with those for the Type 1605-A, in the front section of this instruction book.

3. DISCUSSION OF CHANGES. The main change in the instrument is in the number of turns ratio of the transformer used in the bridge circuit (Figure 1).

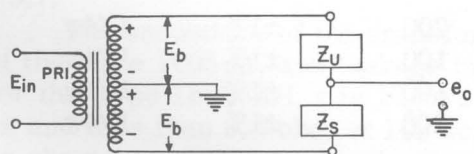

Figure 1.



(The range of the bridge is now 3% and .03 radian, so that the error described is much less than 0.25%.)

Paragraph 4.6, (2):

Delete first sentence ("Note that on the 10%---")

Paragraph 5.1, (2), line 1:

The deviation ranges are 0.1, 0.3, 1, and 3% full-scale for  $\Delta Z$ , and .03, .01, .003, and .001 radian full-scale for  $\Delta \theta$ .

Paragraph 5.2.1, Table:

	R	L	C
100 cps	25 $\Omega$	50 mh	80 $\mu$ f
1 kc	20 $\Omega$	5 mh	8 $\mu$ f
10 kc	20 $\Omega$	500 $\mu$ h	0.8 $\mu$ f
100 kc	40 $\Omega$	200 $\mu$ h	.02 $\mu$ f

Paragraph 5.2.1, (4), line 4:

"The smallest resistance difference that the instrument can detect is  $.003\% \times 20\Omega = 600 \mu$  ohms."

Paragraph 5.2.2, (1), line 10:

"With this method, the low impedance limit is extended to 2 ohms. The smallest deviation that can be detected is  $0.01\% \times 2\Omega = 200 \mu$  ohms."

Paragraph 5.4:

This paragraph no longer applies since there is no 10% range on the Type 1605-AH.

Paragraph 5.5, (1), line 2:

"Within the ranges of the instrument (3% and .03)---"

Paragraph 5.5, (1), line 4:

delete "except for the scale correction necessary when  $\Delta Z$  is large (paragraph 5.4)."

Paragraph 5.5, (4), line 6:

"---meter is indicating 3% or .03 radian-----, which is .005% (.00005 radian) in the worst case."

Paragraph 5.5, (7), line 3:

"---other meter is reading 3% or .03 radian."

Paragraph 5.5, (8), line 6:

"---better than .003% (.00003 radian)."

Paragraph 5.6.

The deviation ranges of the Type 1605-AH may be extended in a similar manner. To obtain a 10% (and a 0.1-radian) range, the calibration should be set to read 10 with the  $\Delta Z$  range switch in the 0.3% position.

Paragraph 5.7.

The secondary of the transformer in the Type 1605-AH has more turns than that of the Type 1605-A, and leakage inductance and resistance are therefore larger. For the Type 1605-AH,  $r$  in Figure 26 is less than 0.3 ohm at low frequencies and less than 0.4 ohm at 100 kc. The value of  $\ell$  is below 1.2  $\mu$ h. This changes the chart on page 14 to the chart on page 4 of this booklet.

Paragraph 7.3.6, substitute the following:

7.3.6 BIAS BAL. Set the CAL control to the 1% level, the FREQUENCY switch to 1 kc, the function switch to ZERO, the IMPEDANCE DIFFERENCE switch to 3%, and the PHASE ANGLE DIFFERENCE switch to .03 radian. Use the ZERO adjustment to zero both meters. Then set the IMPEDANCE DIFFERENCE to 0.1% and PHASE ANGLE DIFFERENCE to .001 radian. Adjust the BIAS BAL control (R337) to restore zero on both meters.

Paragraph 7.3.9, line 3:

"to 3%, the PHASE ANGLE DIFFERENCE switch to .001"

$\Delta Z$  ERROR  
Multiply by 100%

$\Delta \theta$  ERROR  
Radians

TYPE OF LOAD	R	L	C	R	L	C
UNIT	ohms	henries	$\mu f$	ohms	henries	$\mu f$
ERROR FORMULA	$\frac{r}{R}$	$\frac{\ell}{L}$	$-\omega^2 \ell C$	$\frac{\omega \ell}{R}$	$-\frac{r}{\omega L}$	$\omega r C$
FREQUENCY						
100 cps	$\frac{0.3}{R}$	$\frac{1.2}{L} \times 10^{-6}$	$-5C \times 10^{-7}$	$\frac{8}{R} \times 10^{-4}$	$-\frac{5}{L} \times 10^{-4}$	$5C \times 10^{-4}$
1 kc	$\frac{0.3}{R}$	$\frac{1.2}{L} \times 10^{-6}$	$-5C \times 10^{-5}$	$\frac{8}{R} \times 10^{-3}$	$-\frac{5}{L} \times 10^{-5}$	$5C \times 10^{-3}$
10 kc	$\frac{0.3}{R}$	$\frac{1.2}{L} \times 10^{-6}$	$-5C \times 10^{-3}$	$\frac{8}{R} \times 10^{-2}$	$-\frac{5}{L} \times 10^{-6}$	$5C \times 10^{-2}$
100 kc	$\frac{0.4}{R}$	$\frac{1.2}{L} \times 10^{-6}$	$-0.5C$	$\frac{0.8}{R}$	$-\frac{7}{L} \times 10^{-7}$	$0.3C$

Paragraph 7.3.9 through 7.3.9.4:

Change 5% to 1.5% throughout.

Paragraph 7.3.10, line 2:

"to .03 radian"

Paragraph 7.3.10, line 3:

"to 0.1%"

Paragraph 7.3.10, line 7:

"from -.03 to +0.1 percent."

Paragraph 7.3.10.1 through 7.3.10.4:

Change all capacitances to 30% of values specified.

Change -0.2% to -0.018% throughout.

Voltage tables:

Table 7.5

Change ac voltages at TP304 and TP305 to 2.1 (a).

Table 7.6:

Change ac voltages at TP401 and TP401 to 2.3 (a).

Parts List, page 32:

add the following:

R233	200	±1%	1/4w	REF - 65
R234	100	±1%	1/4w	REF - 65
R235	100	±1%	1/4w	REF - 65
R236	200	±1%	1/4w	REF - 65