

**OPERATING AND MAINTENANCE
INSTRUCTIONS**

for

**TYPE 805-C
STANDARD-SIGNAL
GENERATOR**

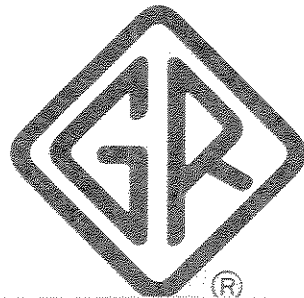

We've Moved
TO OUR NEW PLANT
Our Address is Now
West Concord, Massachusetts
Telephone: EMerson 9-4400

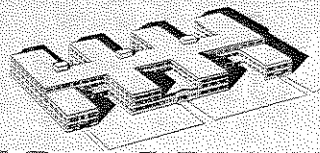

GENERAL RADIO COMPANY

CAMBRIDGE 39

MASSACHUSETTS

U. S. A.

TABLE OF CONTENTS

	<i>Page</i>
Introduction	1
Section 1.0 — Operating Controls and Procedure	1
Section 2.0 — Circuit and Constructional Details	4
Section 3.0 — Output Characteristics as a Function of Frequency	5
Section 4.0 — Routine Adjustments	7
Specifications	10
Service and Maintenance Notes	11

Form 622-J
May, 1958

GENERAL RADIO COMPANY

OPERATING INSTRUCTIONS FOR TYPE 805-C STANDARD-SIGNAL GENERATOR

INTRODUCTION

The Type 805-C Standard-Signal Generator is a precision laboratory instrument designed primarily for the rapid and accurate testing of radio receivers. Its speed and simplicity of operation make it very useful for production testing, while its accuracy, wide frequency range, high output voltage, and high amplitude modulation with low frequency modulation make it a desirable instrument for laboratories engaged in research

and design on radio receivers and allied apparatus.

Functionally this instrument consists of (1) a carrier-frequency oscillator, (2) a tuned radio-frequency amplifier, (3) a resistive output attenuator and a voltmeter to read the output level, (4) a modulation oscillator (400 cycles and 1000 cycles) with a voltmeter for reading percentage modulation, and (5) a well-regulated power supply.

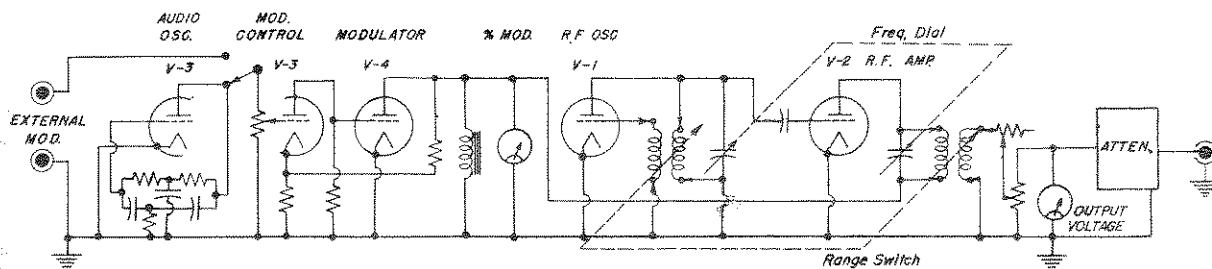

Figure 1. Elementary Schematic Diagram.

SECTION 1.0 OPERATING CONTROLS AND PROCEDURE

1.1 POWER SUPPLY

1.11 Voltage and Frequency: Be sure that the voltage and frequency of the power line are the same as those engraved on the plate at the power line socket. The power transformer is wound for both 115 and 230 volts. Conversion is made by changing transformer connections (see paragraph 2.6).

1.12 Switches: The ON-OFF switch controls the entire power supply. The OSC PLATE switch turns off the generator output without materially altering the heat generated inside the cabinet, and hence allows the generator output to be turned off for short periods, or reduced quickly to zero for check purposes, without an attendant drift in frequency when it is again turned on.

1.2 FREQUENCY

1.21 Range Selector: The frequency range is 16 kilocycles to 50 megacycles. This is covered in a coil-changing mechanism that can be rotated continuously in either direction. The coil ranges are selected by the knob marked RANGE SELECTOR, and the range in use is indicated by the dial marked CARRIER FREQUENCY RANGE. There is also a blank position in which a special set of coils may be placed if desired. Within each band, the frequency is determined by the setting of air condensers, whose plates are shaped to give a logarithmic variation of frequency with angle of dial rotation. Equal angles of rotation correspond to equal percentage increments in frequency.

GENERAL RADIO COMPANY

1.22 Carrier Frequency: The operating frequency is indicated by the large dial marked CARRIER FREQUENCY. The knob marked FAST TUNING may be used between widely separated points on the scale. Frequency scales on the main dial are accurate to better than 1%.

1.23 Frequency Increments: Dial readings can be easily converted to cycles per second for selectivity measurements.

1.24 Frequency Stability: The carrier frequency oscillator has been designed for small frequency drift, without the use of compensators. When coil ranges are switched, an initial frequency drift of approximately $-.05\%$, or less, will be observed. This will occur in the first twenty minutes (approximately) of operation on the coil range immediately switched into position. After this point has been reached, the drift will be in the opposite direction but considerably less in magnitude. The drift rate will be about $+.02\%$ per hour, or less, for the next $2\frac{1}{2}$ hours, and will gradually decrease.

1.3 OUTPUT

1.31 Attenuator and Meter: The output is continuously variable from 0.1 microvolt to 2 volts and is determined by the setting of the attenuator multiplier and the meter reading. The voltage applied to the OUTPUT VOLTAGE meter is adjusted by means of the OUTPUT VOLTAGE knob below it on the panel. The voltage between the terminals marked G and NORMAL on the termination unit is given by the product of the meter reading and the setting of the MULTIPLY BY switch. The NORMAL output impedance is 37.5 ohms, but output may be had at 7.1 ohms and 0.75 ohm by setting the knob on the termination unit to 1:10 and 1:100 respectively. In these cases the output voltage must be further multiplied by 0.1 and 0.01, respectively. The lower impedance settings are not recommended for frequencies above 10 Mc., where accurate results are desired.

1.32 Dummy Antenna: A standard dummy antenna is placed in series with the output voltage when the output is taken from the terminals marked G and DUMMY. The circuit is that of the standard dummy antenna, as specified by the I.R.E. Standards.

1.33 Caution: Care must be taken to prevent the introduction of voltages back into the termination unit from the circuit under test. Currents greater than 50 milliamperes may damage or burn out the resistance units.

1.34 Frequency Characteristic: Variations in output voltage and output impedance as a function of frequency are discussed in Section 3.

1.35 Output Meter Switch: A switch (S-4), operated automatically by the RANGE SELECTOR, changes the response characteristics of this meter so that it is not affected by the presence of modulation on the carrier. This enables the output voltage to be read simultaneously with the modulation percentage, for carrier frequencies above 160 kc. With the RANGE SELECTOR switch in the A or B position, the output meter will indicate the carrier amplitude correctly, provided the modulation does not exceed 1000 cycles. For modulation frequencies above this value, the output meter will tend to read high. Under these conditions, it is necessary to turn off the modulation when reading the OUTPUT meter.

1.4 MODULATION

1.41 Controls: The PERCENTAGE MODULATION is adjusted and indicated by the knob and meter that are so marked. The modulation frequency is controlled by the switch marked MODULATION, which selects either 400 or 1000 cycles from an internal audio oscillator, or, in the EXT. position, selects a modulating voltage from any external source connected to the terminals marked EXTERNAL MOD.

1.42 Meter Accuracy: At carrier frequencies above 500 kc, the accuracy of indication of modulation percentage is $\pm 10\%$ for modulation frequencies between 50 and 15,000 cycles, except on the G carrier range, where the accuracy is $\pm 15\%$.

1.43 Residual Meter Indication: On the A, B, or C ranges a small deflection of this meter may be noted, with the modulation turned off. This is caused by the carrier frequency, but will not impair the readings of the meter at modulation levels above 25%.

1.44 Envelope Waveform: The waveform of the radio frequency envelope is low in distortion, over the entire range of the instrument. Carrier frequency output is essentially sinusoidal on all ranges. Modulation distortion is limited to approximately 4% when the internal modulating oscillator is used, for levels as high as 80% modulation, rising to about 10% at 100% modulation. With an external modulating source, the distortion will depend upon the waveform of the source, and upon the frequency. In general, the distortion tends to increase at the higher modulating frequencies and at the highest modulation percentages. However, it is possible when an external oscillator of low harmonic content is used, to obtain 80% modulation at 15,000 cycles with low envelope distortion.

1.5 CONNECTIONS TO RECEIVER

1.51 Connections to receiver should be made by the cable and termination unit provided. The cable impedance is 75 ohms and is provided with a 75-ohm load, thus providing a net output impedance of 37.5 ohms. This impedance remains essentially constant up to 10 Mc, but changes slightly at higher frequencies owing to the presence of residual reactances in the attenuator and termination unit. This variation is shown in Section 3.

1.52 Leads: The leads between the termination unit and the receiver binding posts should be short and direct. It is preferable to plug the termination unit into the receiver, if convenient.

1.6 USE WITH LOOP RECEIVER

Receivers employing loop antenna pickup can be tested using either of the two standard methods, as outlined in the Standards on Radio Receivers, 1948, of the Institute of Radio Engineers.

The low-impedance-output tap (0.75 ohms) is recommended for use with the method that uses a voltage inserted in series with the antenna loop. To avoid detuning the loop, the signal generator should be connected in series with the grounded, or low r-f potential, end of the loop circuit. *CAUTION:* This method is not recommended for use with the AC-DC type of receiver where one side of the line is connected directly to the receiver chassis. There is considerable shock hazard if the signal generator is operated ungrounded; and there is a danger of introducing sufficient voltage into the attenuator to damage the precision resistances.

A second method involves a transmitting loop antenna inductively coupled to the receiver loop antenna. With such an arrangement, there is no direct connection to the receiver. This offers considerable advantage over the direct connection method, in both convenience and freedom from shock, and avoids possible attenuator damage. It is recommended for use with AC-DC types of receivers. Design of a useful transmitter loop is described in the Proceedings of the Institute of Radio Engineers, Volume 29, No. 7, July 1941.

When using the generator for measurements in the standard broadcast band of frequencies, best results will be obtained when the generator is operated with a good electrical ground. A convenient grounding terminal is located near the OUTPUT terminals of the attenuator. On the highest carrier frequency range, grounding the generator will not make any significant difference in the results obtained.

1.7 USE FOR VIDEO AMPLIFIER TESTING

While the generator was not specifically designed for this use, it can be quite useful in making amplitude versus frequency tests of video amplifiers. Certain precautions must be observed if consistently accurate results are to be obtained.

The OUTPUT VOLTAGE meter of the instrument employs a half-wave diode. The loading effect of this diode introduces a small amount of r-f waveform distortion in the form of peak clipping. This is not serious for radio-receiver testing, but can result in errors of some consequence when the response characteristics of video amplifiers is being measured. This is especially true when an external voltmeter of the peak-response type is used to monitor the output of the amplifier under test. If the video amplifier consists of an odd number of stages, and consequently results in a 180 degree phase reversal between input and output, then the waveform asymmetry will cause a difference in reading between the panel voltmeter of the 805-C and the external monitoring voltmeter.

To avoid this difficulty, the voltmeter used to monitor the output of the amplifier under test should operate with the same polarity as the voltmeter in the signal generator. For an amplifier with an odd number of stages, this would require inverting the monitoring voltmeter. If the amplifier consists of an even number of stages, and does not introduce a 180 degree phase shift, no trouble should be encountered. If these precautions are observed, a Type 1800-B Vacuum-Tube Voltmeter, which is a half-wave peak-response instrument, can be used as the external monitoring voltmeter. The measurements will be within an accuracy consistent with the specifications for the Type 805-C Standard-Signal Generator.

GENERAL RADIO COMPANY

SECTION 2.0

CIRCUIT AND CONSTRUCTIONAL DETAILS

2.1 WIRING DIAGRAM

Figure 2 is a complete wiring diagram.

2.2 RADIO-FREQUENCY SECTION

The master oscillator and r-f amplifier are nearly identical in construction and are mounted in the two-section shielded box in the center of the instrument. Viewed from the panel, the oscillator is on the left and the amplifier on the right. The oscillator tube, V-1, and the amplifier, V-2, are both Type 6L6. Figure 3 shows the general arrangement.

The logarithmic tuning condensers have heavy cast-aluminum frames, with ceramic insulation for both the rotor and the stator. They are coupled together and to the main and increment dials by carefully machined cast-brass gears, which are spring compensated so as to have no appreciable backlash. The coils are mounted on discs in such a way as to keep the length of leads to a minimum. The coil discs are coupled together to a detent mechanism by the same type of gears used in the tuning condenser gear train.

2.3 OUTPUT SYSTEM

The output voltmeter is at the right-hand end of the instrument. An Amperite 3-4 (V-10) is mounted on the modulation shelf. This is connected in series with the heaters of the output- and modulation-voltmeter tubes to reduce the effect of line voltage fluctuations. The output voltmeter tube (V-9) is a Type 6AL5 Tube and is located inside the attenuator multiplier shield. One section of the 6H6 double triode (V-11) is used to provide a bucking voltage to balance the initial diode current of the 6AL5 tube (V-9) to zero. The output potentiometer is a form of "L" pad. The multiplier is a ladder network. The attenuator is designed for operation up to 50 megacycles.

2.4 MODULATOR

The modulator section is on the upper shelf at the left end of the instrument. Viewed from the panel, the three tubes on this shelf are, from left to right, a 6C8G duplex triode (V-3), a 6L6 beam power amplifier (V-4), and a 6H6 rectifier (V-11).

One half of the 6C8G (V-3) is used as the internal audio oscillator to supply frequencies at either 400 or

1000 cycles from a parallel "T" type, resistance-capacitance oscillator circuit. The other half is a pre-amplifier for both internal and external modulation. The 6L6 (V-4) is the modulating power-amplifier tube. Modulation is applied to the plate and screen of the r-f amplifier (Type 6L6) so as to minimize frequency modulation at high percentages of amplitude modulation. One half of the 6H6 tube (V-11) is in the circuit of the modulation vacuum-tube voltmeter.

2.5 PANEL METERS

Individual panel meters are provided for simultaneously indicating the amplitude of the radio-frequency output voltage and the modulation percentage.

2.51 Modulation Meter: An average-response, diode rectifier (6H6, V-11) is used to measure the amplitude of the audio-frequency voltage applied to the modulator stage (6L6, V-2). A d-c microammeter (M-2) measures the current in the diode circuit and is calibrated directly in percentage modulation.

The calibration of this meter, for each range, is effected by resistors located on the oscillator turret gear and can be reached through a snap button on the panel.

2.52 Output Meter: A diode rectifier (6AL5, V-9) is used to measure the carrier frequency amplitude at the input to the attenuator. The meter scale is calibrated in terms of the r-m-s output voltage appearing at the end of the cable and indicates the voltage across the NORMAL terminals.

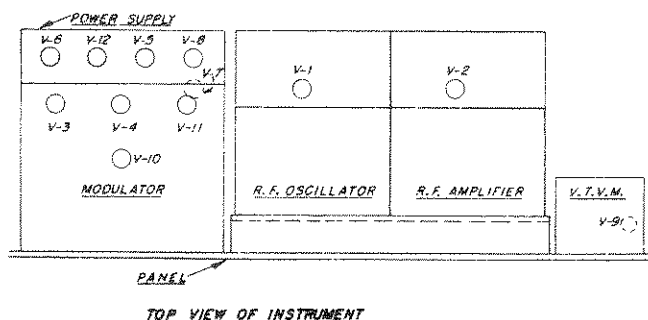

Figure 3. Location of Tubes.

2.6 POWER SUPPLY

The power supply is mounted on the lower shelf at the left end of the instrument. This shelf supports five tubes, which, viewed from the panel and from left to

GENERAL RADIO COMPANY

right, are two Type 2A3 tubes (V-6 and V-12), a Type 5U4G Rectifier (V-5), a Type VR-150-30 Voltage Regulator (V-8), and in front of this, under the upper shelf, a Type 6SF5 (V-7). The 2A3's, the VR-150-30, and the 6SF5 (V-6, V-12, V-8 and V-7, respectively) are in the electronic voltage regulator circuit. This regulator will take care of normal line voltage fluctuations between 105 and 125 volts, the line voltage for which the generator is normally connected. However, the connections to the power transformer may be changed so as to make the regulator work from 210 to 250 line volts.

The power transformer is mounted on the lower left end shelf, and the primary taps (numbered 1, 2, 3 and 4) are on a black bakelite strip on the upper rear of this transformer. When the instrument is out of the cabinet these terminals are accessible from the rear without removing tubes or parts.

For 105- to 125-volt operation, connect jumpers from terminal No. 1 to terminal No. 3 and from terminal No. 2 to terminal No. 4.

For 210- to 250-volt operation, connect a jumper

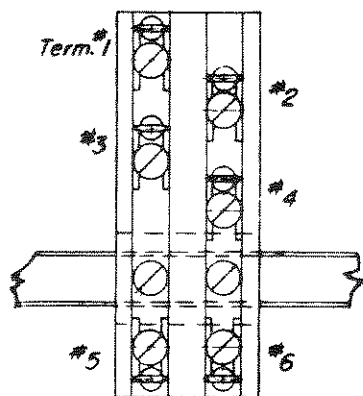

Figure 4. Identification of terminals on terminal blocks of r-f inductors.

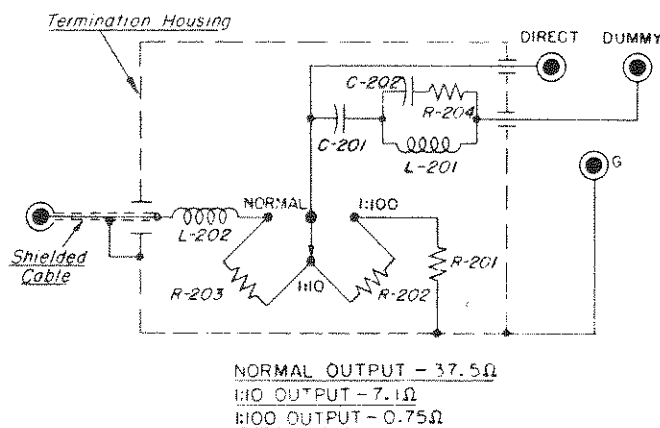

Figure 5. Wiring Diagram of Type 805-P1 Termination Unit.

from terminal No. 2 to terminal No. 3.

In either case, the green wires with yellow tracer connect to terminals No. 1 and No. 3.

When the generator is shipped, the small plate at the power inlet indicates the line voltage for which the transformer is connected. If connections are changed, reverse this plate.

2.7 CAUTION

If it is necessary to operate the instrument outside of its cabinet, an extension cord should be used to connect the instrument to the power plug located inside the cabinet. Unless this is done the instrument will not be protected by the line fuses.

SECTION 3.0

OUTPUT CHARACTERISTICS AS A FUNCTION OF FREQUENCY

3.1 VOLTAGE

Output voltage errors arise from several sources, namely

- (1) Errors in the output voltmeter.
- (2) Errors resulting from residual reactances in the termination unit.
- (3) Errors in attenuation ratio resulting from resistance and reactance variations between attenuation steps.

3.11 Voltmeter Errors: The plot of Figure 6 shows

the maximum error to be expected on the 1-volt multiplier when all sources of error are additive. The error below 25 Mc is entirely residual calibration error, including such factors as the normal uncertainty of setting to the 2-volt line, and, the effect of waveform at low frequencies. The use of a logarithmic scale results in a substantially uniform accuracy over a complete decade. This is $\pm 5\%$ of the indicated reading.

Above 25 Mc, a frequency error in voltmeter response

GENERAL RADIO COMPANY

amounting to $\pm 6\%$ at 50 Mc is added; and, at 1/10 full scale, a further transit time error in the voltmeter tube of -5% .

3.12 Termination Unit: Shunt capacitance in the termination unit causes a gradual dropping off in voltage as the frequency is increased. This error is compensated by a series loading coil located inside the termination unit, and the net error is included in the figures given above in paragraph 3.11.

3.13 Attenuator Error: A maximum variation of $\pm 1\%$ occurs in the adjustment of individual resistors in the attenuator. Variations in the reactance of these resistors, however, is more important and accounts for most of the frequency error, which rises to $\pm 15\%$ at 50 Mc. Figure 7 shows this maximum error as a function of frequency.

(RIGHT)

Figure 6. Maximum voltmeter error as a function of frequency when all component errors are additive. This is the maximum error in output voltage at the 1v multiplier position.

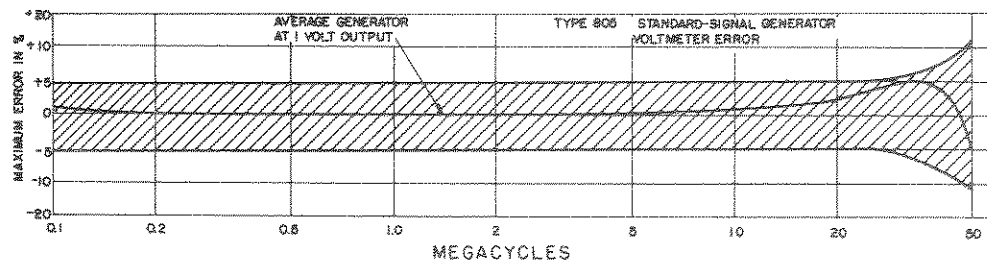

3.14 Total Error: The total possible error is the sum of the voltmeter and attenuator errors given above. Obviously, some of these errors will tend to cancel, and the actual error may be less than is indicated by these figures. In Figure 6, the average total error for 10 typical generators is shown by the curve marked "Average Generator at 1-Volt Output."

3.15 Direct Leakage in Attenuator: Direct leakage, one source of which is capacitance across the attenuator from input to output, results in a fixed error which is effective only on the lowest multiplier step, and increases with frequency. This is shown in Fig. 8.

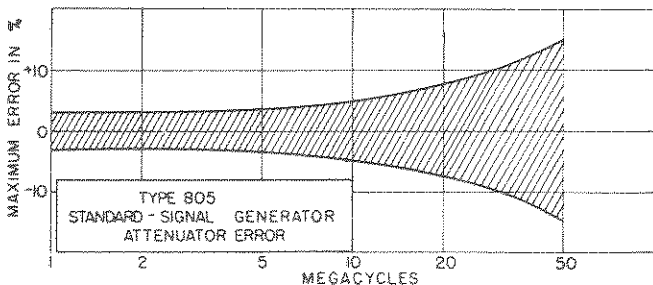
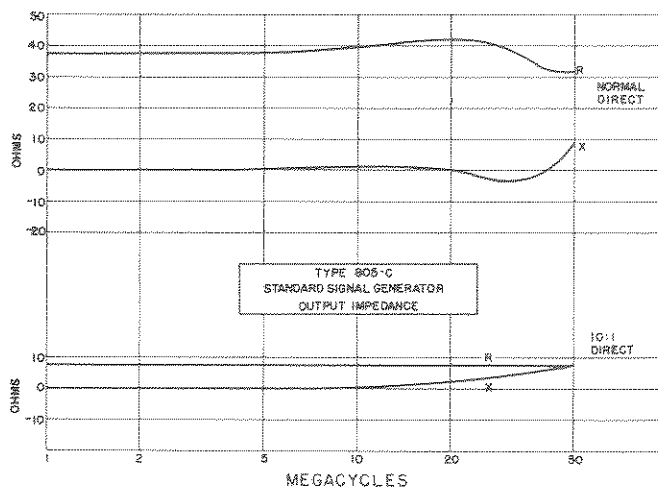

Figure 9. Frequency characteristic of output impedance at termination unit.

Figure 7. Maximum attenuator error as a function of frequency.

3.2 OUTPUT IMPEDANCE

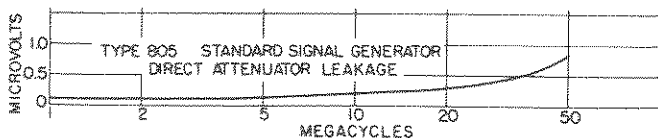

Figure 8. Direct attenuator leakage as a function of frequency. This is significant only on the lowest multiplier position.

3.21 Residual inductance in the attenuator and shunt capacitance in the termination unit switch cause the output impedance at the termination unit to deviate at high frequencies from its low-frequency resistive value of 37.5 ohms. The output impedance as a function of frequency at the DIRECT output plug is given in Figure 9 for both the NORMAL and 10:1 positions of the switch. For the 100:1 position, the impedance varies in essentially the same way, but the resistance is reduced to 0.75 Ω .

GENERAL RADIO COMPANY

3.22 Consequently, the open-circuit voltage at the termination unit is seen in series with the impedance indicated by these curves. For load impedances that are not high compared to this generator impedance, load voltage will differ from this open-circuit value. If the load impedance is known, the voltage division can be calculated. The load impedance can be measured on a Type 1606-A Radio-Frequency Bridge.

3.23 The reactive component of output impedance for the 10:1 position rises to a value greater than the resistive component at high frequencies. This position is not intended for use at frequencies above 10 megacycles.

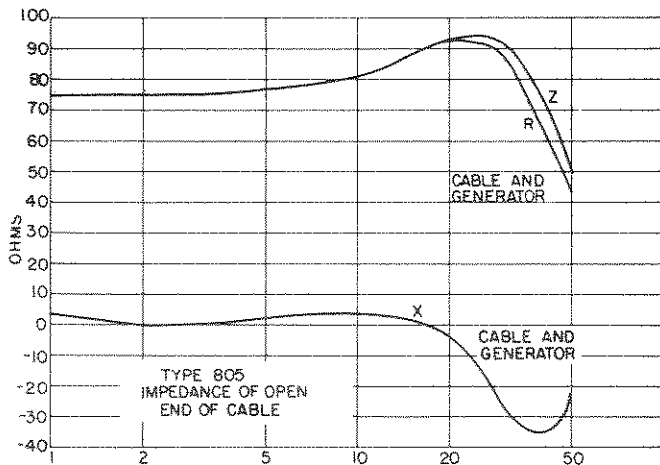

Figure 10. Output impedance at open end of cable.

3.3 GENERATOR AND CABLE IMPEDANCE

3.31 If the termination unit is not used, higher open-circuit output voltages can be obtained because the 2:1 drop in voltage caused by the cable termination is avoided. If the attenuator had no reactance, the impedance at the open end of the cable would be 75

ohms resistive, and the open-circuit output voltage would be twice that indicated by the generator output calibration, which is correct for a terminated cable.

3.32 With the termination unit removed (this can be done by unsoldering the cable at the termination unit or by substituting an equivalent cable of the same length and impedance), the impedance characteristic is that shown in Figure 10, and the open-circuit voltage is twice that indicated by the output meter and attenuator.

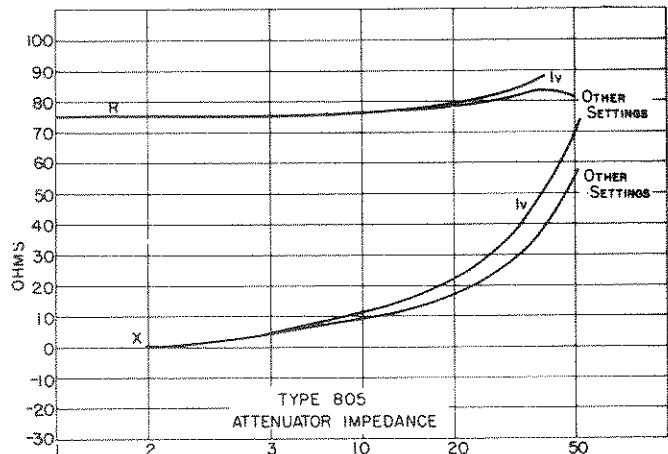

Figure 11. Attenuator impedance as a function of frequency.

3.33 The deviation in impedance from the normal resistive value of 75 ohms is caused by inductance in the attenuator, whose characteristic is shown in Figure 11. Since the attenuator and cable system is series resonant at approximately 20 megacycles, the sign of the reactance seen at the open end of the cable is reversed at higher frequencies, as shown in Figure 10.

SECTION 4.0

ROUTINE ADJUSTMENTS

4.1 PANEL ADJUSTMENTS

There are five adjustments under snap buttons, which may be readjusted from time to time as it becomes necessary. They are as follows:

4.11 **Internal Modulation Frequency Adjustments:** Separate adjustments marked MOD. ADJ. 400 and MOD. ADJ. 1000 are provided for the 400- and 1000-cycle modulating frequencies. These are in-

tended to be adjusted for minimum harmonic content, and should be set so that the oscillator just oscillates stably.

4.12 **Zero Adjustments on Output Meter:** With the instrument turned off, this voltmeter should be set at zero by means of the manual adjustment on the meter itself. When the instrument is operating and fully warmed up, the meter should be reset to zero, as necessary, by means of the control marked ZERO ADJ.

GENERAL RADIO COMPANY

This adjustment should be made with the PL. VOLTS switch in the OFF position. (The OUTPUT control will not attenuate the output voltage to exactly zero, especially at the higher carrier frequencies.)

4.13 Calibration Adjustment of Output Meter: Having made the correct zero adjustment, turn the PL. VOLTS switch ON, and set the carrier frequency to approximately 1.0 Mc. Connect a vacuum-tube voltmeter, such as the GR Type 1800, across the NORMAL terminals of the termination unit. The internal impedance of the voltmeter used should be at least 4000 Ω at 1.0 Mc, and the calibration should be known to $\pm 1\%$ or better. Adjust the OUTPUT control until the external voltmeter reads exactly 2.0 volts. Remove the snap button from the point marked CAL on the panel, and set the adjustment so that the OUTPUT meter reads exactly on the 2.0 point.

For this adjustment, the external VTVM leads should be as short as possible.

4.14 Calibration Adjustment of Percentage Modulation Meter: This setting has been carefully made at the factory, using precision measuring instruments, and should not be attempted unless suitable test equipment is available. The small snap-button located just above, and to the right of, the main tuning dial conceals the potentiometer used to set the sensitivity of the PERCENTAGE MODULATION meter. Individual potentiometers are provided for each range, and are automatically selected by the RANGE SELECTOR switch.

4.15 Other Zero Adjustments: The PERCENTAGE MODULATION meter should be set to zero by means of its manual adjustment when the instrument is fully warmed and in operation. Do this with the modulation switch in the OFF position and with the RANGE switch set on the D range. (On the A, B, and C ranges the carrier produces a small zero reading on the PERCENTAGE MODULATION meter.)

4.16 Lubrication of Moving Parts: The CARRIER FREQUENCY INCREMENT dial rotates on a steel shaft and bushing. Removal of this dial by loosening the two setscrews will expose an oil-hole in the end of the shaft. A few drops of machine oil per year will provide adequate lubrication.

All gears associated with the coil-changing mechanism, the dial drive, and the contact surfaces of the OUTPUT VOLTAGE control may be lubricated as necessary with Liqui-Moly N. V. Grease (obtainable from the Lockrey Company, College Point, N. Y.).

4.2 INTERNAL ADJUSTMENTS

4.21 Plate Voltage Adjustment: This is located on the side of the power supply shelf. The plate voltage should be set to 290 volts by means of the potentiometer (R-28). An external meter, connected between terminal No. 1 of the choke (L-5) and ground, may be used as a reference voltmeter. A 1000-ohms-per-volt instrument is satisfactory. If the plate-voltage supply regulator is operating correctly, no change in the voltmeter reading will be observed as the supply line voltage is varied from 105 to 125 volts.

4.3 LEAKAGE

The lower limit of usefulness of the attenuator is determined by the amount of radio-frequency leakage radiation from the generator. This should be less than 5 microvolts per meter at any point 24 inches from the panel. Care must be taken, in making adjustments, not to do anything that will cause the leakage to be excessive. The following are points to check.

4.41 All the snap buttons should be in place and the holes should be clean so that the buttons are properly grounded.

4.42 The RANGE SELECTOR, CARRIER FREQUENCY INCREMENT, FAST TUNING and OUTPUT VOLTAGE knobs have washers, spacers, and bearing plates under them to ground the brass hubs, and setscrews in the knobs, to the front surface of the panel. The main dial hub also is provided with a special panel grounding spring and is insulated from the shaft. These points should be checked if for any reason the knobs are removed. Additional grounding is provided, internally, by means of a coil spring directly in back of the panel plates.

4.43 The cover over the CARRIER FREQUENCY RANGE dial should be firmly grounded to the panel. No paint or dirt should be on the grounding surfaces.

4.44 The instrument panel should be well grounded to the cabinet at all points, and all the cabinet-panel screws should be tight. The panel frame should make good contact with the edge of the panel at all points.

4.45 Checking Leakage: Since leakage from a signal generator can arise from several different sources, it is necessary to proceed in a logical manner to isolate the cause of any suspected leakage. First, the character of the receiver pickup will determine the general nature of the leakage field. A loop-type antenna located near the generator will be inductively coupled to the generator, and hence the induction leakage fields set up by the generator will be the predominant source of trouble.

GENERAL RADIO COMPANY

A dipole antenna will respond mainly to the electrostatic, or radiation, leakage fields from the generator.

The induction leakage field of the generator may be checked by means of a small coil, consisting of 40 turns of wire on a $2\frac{3}{4}$ inch form. When the coil is connected to the input terminals of a radio receiver, less than one microvolt pickup at a frequency of one megacycle, should be obtained across the coil terminals when the coil is placed directly upon the surfaces of the generator. If excessive leakage is found, it can be traced to such troubles as poor contacts between shields, or between the panel and the cabinet, or parts mounted on the panel. To eliminate successfully leakage of this nature, the parts involved must be made to have a low impedance contact and hence it is well to clean contact surfaces of shields, etc. in order to remove any oxide films that may have formed.

If the induction leakage fields are not excessive, it will be found that the radiation components of the leakage field will be negligible since the correction measures necessary to reduce the former will almost always eliminate the latter. However, to check for leakage of this sort it is advisable to use a dipole antenna. The equivalent leakage should be less than 5 microvolts per meter at a distance of 24 inches.

Leakage from the line-filter, which may be introduced to the receiver via the power supply mains, can be located by using a small capacitor probe, in series with the antenna lead of the radio receiver. With the signal generator operating ungrounded (within a suitable shielded room) touch the probe to the generator at several points. Not more than two microvolts should be obtained on the receiver input. When a ground is connected to the generator the signal should drop below 0.2 microvolts. At the highest frequencies, no observable signal should be noticed, with the generator grounded, or ungrounded.

When checking for leakage, it is preferable to use a radio receiver that includes a beating oscillator, so that equal r-f leakage fields are detected equally regardless of whether or not they are modulated. Leakage fields originating in the unmodulated sections of the generator might escape detection unless this latter method is used. Similarly, the "S Meter" on certain types of receiver may be employed for the same purpose.

4.5 LOCATION OF TUBES AND FUSES

Designation	Type	Location
V-1	6L6	Left side of large center section.
V-2	6L6	Right side of large center section.
V-3	6C8G	Upper shelf at left end of instrument.
V-4	6L6	Upper shelf at left end of instrument.
V-5	5T4 (or 5U4G)	Lower shelf at left end of instrument.
V-6	2A3	Lower shelf at left end of instrument.
V-7	6SF5	Lower shelf at left end of instrument.
V-8	VR-150-30	Lower shelf at left end of instrument.
V-9	6AL5	In attenuator compartment at right end of instrument.
V-10	Amperite 3-4	On shelf at left end of instrument in front of V-4.
V-11	6H6	Upper shelf at left end of instrument.
V-12	2A3	Lower shelf at left end of instrument.
F-1 } F-2 }	Fuses	Located on rear of cabinet near power input plug.
P-1	Pilot Light	6.3-volt G.R. No. 2 LAP-939 Bayonet pin base.

The pilot light is replaceable from the front panel by unscrewing the front of the red jewel indicator, marked FIL. PL.; the fuses, by unscrewing the plugs marked FUSE, in the rear of the cabinet.

GENERAL RADIO COMPANY

SPECIFICATIONS

Carrier Frequency Range: 16 kilocycles to 50 megacycles, covered in seven direct-reading ranges, as follows: 16 to 50 kc, 50 to 160 kc, 160 to 500 kc, 0.5 to 1.6 Mc, 1.6 to 5.0 Mc, 5.0 to 16 Mc, 16 to 50 Mc. A spare range position is provided so that a special set of coils can be installed if desired.

Frequency Calibration: Each range is direct reading to an accuracy of $\pm 1\%$ of the indicated frequency.

Frequency Drift: Not greater than $\pm 0.1\%$ on any frequency range for a period of 5 hours' continuous operation.

Incremental Frequency Dial: A slow-motion vernier drive dial is provided, by means of which frequency increments as small as 0.01% may be obtained.

Output Voltage Range: Continuously adjustable from 0.1 microvolt to 2 volts. The output voltage (at the termination of the 75-ohm output cable) is indicated by a panel meter and seven-point multiplier.

Output System: The output impedance at the panel jack is 75 ohms, resistive. A 75-ohm output cable is provided, together with a termination unit that furnishes constant output impedances of 37.5, 7.1, and 0.75 ohms. The calibration of the panel voltmeter-multiplier combination is in terms of the actual voltage across the 37.5-ohm output. When the 7.1- and 0.75-ohm positions are used, the indicated output voltage must be divided by 10 and 100, respectively. A standard dummy-antenna output is also available at the termination unit.

Output Voltage Accuracy: For multiplier settings below 1 volt the maximum error in output voltage is the sum of the attenuator and voltmeter errors listed below.

Maximum Voltmeter Error: $\pm 5\%$ of indicated reading up to 25 megacycles. Above 25 megacycles, an additional frequency error occurs, amounting to a total of $\pm 7\%$ at 50 megacycles. At $\frac{1}{2}$ full scale and 50 Mc, there is also a transit-time error of -5% in the voltmeter tube.

Maximum Attenuator Error:

- Below 3 Mc, $\pm(3\% + 0.1 \text{ microvolt})$
- 3 to 10 Mc, $\pm(5\% + 0.2 \text{ microvolt})$
- 10 to 30 Mc, $\pm(10\% + 0.4 \text{ microvolt})$
- 30 to 50 Mc, $\pm(15\% + 0.8 \text{ microvolt})$

There is no attenuator error for the 1-volt multiplier setting.

Modulation: Continuously variable from 0 to 100%. The percentage of modulation is indicated by a panel meter to an accuracy of $\pm 10\%$ of the meter reading up to 80%, for carrier frequencies below 16 Mc; $\pm 15\%$ for higher carrier frequencies.

Internal modulation is available at 400 cycles and 1000 cycles, accurate in frequency within $\pm 5\%$.

The generator can be modulated by an external oscillator. Approximately 10 volts across 500,000 ohms are required for 80% modulation. The over-all modulation characteristic is as follows:

Carrier Frequency	Audio Range	Level
0.5—50 Mc	50c —15,000c	± 1 db
0.1—0.5 Mc	50c —10,000c	± 1.5 db
16—100 kc	50c —10% of Carrier Frequency	± 1.5 db

Frequency Modulation: On the highest carrier frequency range the frequency modulation is about 0.05% for 100% modulation, and 0.02% for 30% modulation. At lower carrier frequencies the frequency modulation is less than these percentages.

Above 20 Mc for applications where incidental fm must be negligible or for wideband (video) modulation, the TYPE 1000-P6 Crystal Diode Modulator should be used.

Distortion and Noise Level: The envelope distortion at a modulation level of 80% is less than 5% at 1 Mc carrier frequency. Carrier noise level is at least 40 db below 80% modulation.

Leakage: The magnetic induction leakage is less than 5 microvolts per meter at a distance of 2 feet from the generator. The 3-foot output cable permits the receiver under test to be kept beyond this limit. Radiation fields are negligible.

Power Supply: The instrument operates from any 40 to 60 cycle, 115-volt (or 230-volt) line. An electronic voltage regulator compensates for line voltage fluctuations from 105 to 125 volts (or from 210 to 250 volts). A maximum input power of 150 watts is required.

Tubes: Supplied with instrument.

- 1 — 6C8-G
- 3 — 6L6
- 1 — 5U4-G
- 2 — 2A3
- 1 — 6SF5
- 1 — 0D3
- 1 — 6AL5
- 1 — 6H6
- 1 — Amperite 3-4

Accessories Supplied: Line connector cord, shielded output cable and termination unit, and spare fuses.

Mounting: The panel is finished in black crackle and the cabinet is black wrinkle finish.

Dimensions: (Height) 16 x (width) 33 x (depth) 12 inches, over-all.

Net Weight: 117½ pounds.

THIS APPARATUS USES INVENTIONS OF UNITED STATES PATENTS LICENSED BY RADIO CORPORATION OF AMERICA. PATENT NUMBERS SUPPLIED UPON REQUEST. NOT LICENSED FOR DOMESTIC, FIXED-STATION, PUBLIC SERVICE COMMUNICATION FOR HIRE OR TOLL.

GENERAL RADIO COMPANY

**SERVICE AND MAINTENANCE NOTES
FOR THE
TYPE 805-C STANDARD-SIGNAL GENERATOR**

GENERAL RADIO COMPANY

TABLE OF CONTENTS

	<i>Page</i>
Complete Wiring Diagram	14-15
1.0 Foreword	17
2.0 General	17
3.0 Input Power	17
4.0 Generator Inoperative	17
5.0 No Reading of Output Meter at Any Range	18
6.0 No Reading of Output Meter Except on G Range	18
7.0 No Reading of Output Meter on One or More Ranges	18
8.0 Low Reading of Output Meter	18
9.0 Erratic Output with Normal Reading of Output Meter	19
10.0 No Output but Output Meter Reads	19
11.0 Erratic Operation of Output Meter	20
12.0 Inoperative Modulation Meter	20
13.0 Modulation Meter Reads on Some Settings	20
14.0 Low Modulation Meter Readings	21
15.0 Erratic Operation of Modulation Meter	21
16.0 Hum Modulation on Carrier	21
17.0 Voltage Regulator and Power Supply	21
18.0 Tube Data and Tube Replacements	22
19.0 Removal of Turrets	22
20.0 Carrier Frequency Calibration	22
21.0 Calibration of Percentage Modulation Meter	23
22.0 Adjustment of Output Voltage Meter	23
23.0 Modulation VTVM Frequency Characteristic	23
24.0 Continuity Check	24
25.0 Lubrication	24
26.0 Vacuum-Tube Data	24
Equipment Recommended for Complete Test and Calibration	25
Interior Views with Parts Identification	26-28

GENERAL RADIO COMPANY

PARTS LIST

				PART NO. (NOTE A)					PART NO. (NOTE A)
RESISTORS (NOTE B)	R1	300	± 5%	4 w	REPO-1018	R110	13.5	± 1%	805-335
	R2	100	± 10%	1 w	REW-4C	R111	135.0	± 1%	805-331
	R3	33k	± 10%	1/2w	REC-20BF	R112	16.69	± 1%	
	R4	1k	± 5%	4 w	REPO-1078	R113	133.65	± 1%	805-333
	R5	680k	± 10%	1/2w	REC-20BF	R114	16.50	± 1%	
	R6	150	± 20%	1 w	REW-4C	R115	133.65	± 1%	805-333
	R7	47k	± 10%	1 w	REC-30BF	R116	16.50	± 1%	
	R8A	400				R117	133.65	± 1%	805-333
	R8B	115			805-27	R118	16.50	± 1%	
	R9	505k	± 1%	1/2w	REF-1	R119	133.65	± 1%	805-333
	R10	505k	± 1%	1/2w	REF-1	R120	16.50	± 1%	
	R11	100k	± 10%		POSC-11	R121	133.65	± 1%	805-332
	R12	47k	± 10%	1/2w	REC-20BF	R122	14.85	± 1%	
	R13	194k	± 1%	1/2w	REF-1	R123	61.5	± 1%	805-434
	R14	194k	± 1%	1/2w	REF-1	R124	56k	± 10%	
	R15	50k	± 10%		POSC-11	R125	27k	± 10%	1/2w
	R16	22k	± 10%	1/2w	REC-20BF	R126	27k	± 10%	1/2w
	R17	15k	± 1%		REPR-16	R127	100	± 10%	1/2w
	R18	5.6k	± 10%	1/2w	REC-20BF	R128	56k	± 10%	1/2w
	R19	5k	± 10%		POSW-3	R129	8.2k	± 10%	1 w
	R20	50k	± 10%		POSC-11	R130	1k	± 10%	1/2w
	R21	100k	± 1%	1/2w	REF-2		1k	± 10%	1/2w
	R22	1M	± 10%	1 w	REC-30BF	R132	6.8k	± 10%	2 w
	R23	27k	± 10%	1/2w	REC-20BF		6.8k	± 10%	2 w
	R24	6k	± 10%	10 w	REPO-22P	R133	3.3k	± 10%	2 w
R25	22k	± 10%	2 w	REC-41BF	R134	22k	± 10%	1/2w	
R26	1M	± 10%	1/2w	REC-20BF	R135	10k	± 10%	1/2w	
R27	100k	± 10%	1 w	REC-30BF	R136	22k	± 10%	1/2w	
R28	50k			301-437-2	R201	0.75	± 1%	1/2w	
R29	100k	± 10%	1 w	REC-30BF	R202	6.75	± 1%	1/2w	
R30	150	± 10%	1 w	REW-4C	R203	67.5	± 1%	1/2w	
R31	1k	± 10%	1 w	REC-30BF	R204	390	± 5%	1/2w	
R32	100k	± 1%		REPR-16	R205	820k	± 10%	1/2w	
R33	50k	± 1%		REPR-16					
R34	560k	± 10%	1/2w	REC-20BF	C1	0.5µf	± 10%	600dcwv	COL-13
R35	470k	± 10%	1/2w	REC-20BF	C2	0.02µf	± 10%	600dcwv	COM-50B
R36	3.3k	± 10%	2 w	REC-41BF	C3	0.02µf	± 10%	600dcwv	COM-50B
R37	3.3k	± 10%	2 w	REC-41BF	C4	0.02µf	± 10%	600dcwv	COM-50B
R38	500k	± 10%		POSC-7	C4A	20µf	+50% - 10%		Part of
R39	100k	± 10%	2 w	REC-41BF					COEB-20
R40	100k	± 10%	2 w	REC-41BF	C5	5			805-435
R41	560k	± 10%	1/2w	REC-20BF	C6	50-1080 (nominal)			539-414
R42	220	± 10%	2 w	REW-6C	C7A	50			COA-16
R43	25k	± 10%	40 w	REPO-21P	C7B	50			COA-16
R44	100k	± 10%	2 w	REC-41BF	C7C	50			COA-16
R45	220	± 10%	1 w	REW-4C	C7D	50			COA-16
R46	220	± 10%	1 w	REW-4C	C7E	50			COA-16
R47	560	± 10%	1 w	REC-30BF	C7F	50			COA-16
R48	1k	± 10%	1/2w	REC-20BF	C7G	50			COA-16-2
R49	10k	± 10%	2 w	REC-41BF	C8	0.01µf	± 10%		COM-41B
R51	100k	± 1%	1/2w	REF-2	C9	20µf	+50% - 10%		Part of
R52	68k	± 10%	1/2w	REC-20BF					COEB-20
R54	100	± 10%	1/2w	REC-20BF	C10	25µf	+50% - 10%		COEB-4
R55	100	± 10%	1/2w	REW-3C	C11	0.02µf	± 10%	600dcwv	COM-50B
R56	1.5k	± 5%	4 w	REPO-1043	C12	20	± 10%	300dcwv	COM-20B
R57	68k	± 10%	2 w	REC-41BF	C13A	200	± 10%	300dcwv	COM-20B
R59	2.7M	± 10%	1/2w	REC-20BF	C13B	20	± 10%	300dcwv	COM-20B
R60	50k	± 1%		REPR-16	C13C	50	± 10%	300dcwv	COM-20B
R101	50k	± 20%		POSC-20	C13D	50			COA-16
R102	50k	± 20%		POSC-20	C13E	50			COA-16
R103	100k	± 20%		POSC-20	C13F	50			COA-16
R104	250k	± 20%		POSC-20	C13G	100			COA-4
R105	100k	± 20%		POSC-20	C14	50-1080 (nominal)			539-414
R106	250k	± 20%		POSC-20	C15	0.001µf	± 10%	500dcwv	COM-41B
R107	100k	± 20%		POSC-20	C16	0.001µf	± 10%		COU-19
R108	2.7k	± 10%	1/2w	REC-20BF	C17	0.001µf	± 10%		COU-19
R109	5.6k	± 10%	1/2w	REC-20BF	C18	0.001µf	± 1%	600dcwv	COM-45C
					C19	0.001µf	± 1%	600dcwv	COM-45C

For explanation of NOTES, refer to page 16.

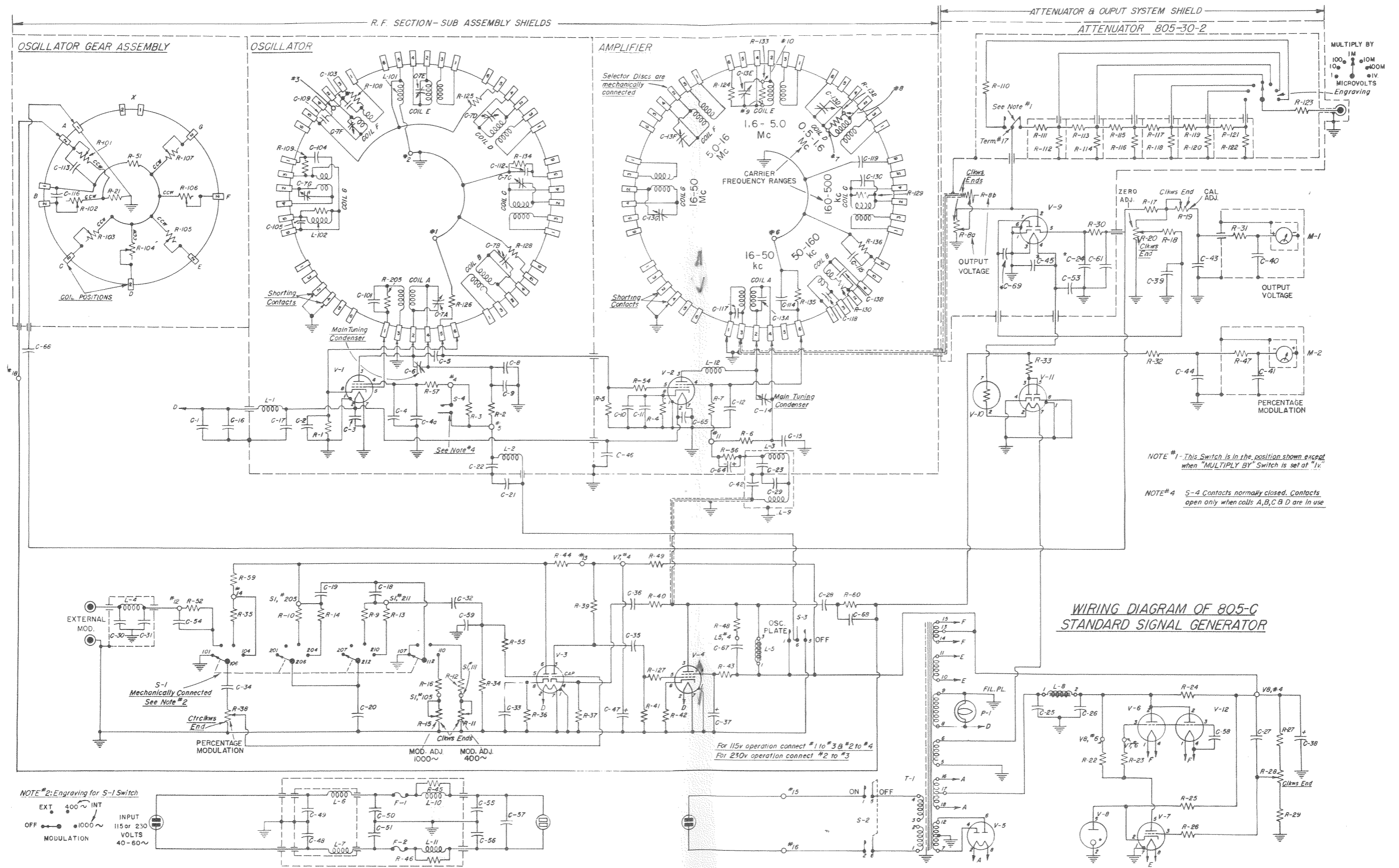

FIGURE 2.
WIRING DIAGRAM FOR TYPE 805-C STANDARD-SIGNAL GENERATOR.

GENERAL RADIO COMPANY

PARTS LIST (Cont.)

			PART NO. (NOTE A)			PART NO. (NOTE A)		
CAPACITORS (NOTE C)	C20	0.002µf ± 1%	600dcwv	COM-45C	C117	0.01µf ± 10%	500dcwv	COM-41B
	C21	0.001µf ± 10%		COU-9	C118	0.015µf ± 10%	600dcwv	COM-50B
	C22	0.001µf ± 10%		COU-9	C119	250 ± 10%	300dcwv	COM-20B
	C23	500 ± 10%		COU-8-2	C201	200 ± 5%	300dcwv	COM-20B
	C24	750 ± 20%		(NOTE D)	C202	400 ± 5%	300dcwv	COM-20B
	C25	0.5µf ± 10%	1000dcwv	COL-24		F1	FUSE, 1.6 amp Slo-Blo Type 3AG (for 115v)	FUF-1
	C26	10µf ± 10%		COL-9(2)		F1	FUSE, 0.8 amp Slo-Blo Type 3AG (for 230v)	FUF-1
	C27	0.25µf ± 10%		COL-3		F2	FUSE, 1.6 amp Slo-Blo Type 3AG (for 115v)	FUF-1
	C28	0.5µf ± 10%	1000dcwv	COL-24		F2	FUSE, 0.8 amp Slo-Blo Type 3AG (for 230v)	FUF-1
	C29	500 ± 10%		COU-8-2		L1	INDUCTOR	P-432-315
	C30	50 ± 10%		COU-24		L2	CHOCHE, 2.5 mh	CHA-597
	C31	50 ± 10%		COU-8-2		L3	CHOCHE, 2.5 mh	CHA-597
	C32	0.05µf ± 10%	600dcwv	COM-50B		L4	CHOCHE, 2.5 mh	CHA-597
	C33	16µf + 50% - 10%		COE-4		L5	INDUCTOR	485-427-2
	C34	0.05µf ± 10%	600dcwv	COM-50B		L6	INDUCTOR	804-310
	C35	0.05µf ± 10%	600dcwv	COM-50B		L7	INDUCTOR	804-310
	C36	0.25µf ± 10%	1000dcwv	COL-26		L8	INDUCTOR	485-428-2
	C37	20µf + 50% - 10%		Part of COEB-9	L9	CHOCHE, 2.5 mh	CHA-597	
	C38	40µf + 50% - 10%		Part of COEB-9	L10	INDUCTOR	805-406	
	C39	100 ± 10%		COU-8-2	L11	INDUCTOR	805-406	
	C40	0.001µf ± 10%	500dcwv	COM-21B	L12	INDUCTOR	805-873	
	C41	0.001µf ± 10%	500dcwv	COM-21B	L101	CHOCHE, 2.5 mh	CHA-597	
	C42	500 ± 10%		COU-8-2	L102	INDUCTOR	805-39-2	
	C43	0.001µf ± 10%		COU-9	L201	INDUCTOR, 20 µh	Part of 805-319	
	C44	0.001µf ± 10%		COU-9	L202	INDUCTOR	805-870	
	C45	0.001µf ± 20%		(NOTE D)	M1	METER, 200 µa	588-315-3	
	C46	0.001µf ± 10%		COU-9	M2	METER, 200 µa	588-314	
	C47	20µf + 5% - 10%		Part of COEB-9	P1	LAMP, 6.3v Mazda #44	2LAP-939	
	C48	0.001µf ± 10%	500dcwv	COM-21B	S1	SWITCH	SWRW-28	
	C49	0.001µf ± 10%	500dcwv	COM-21B	S2	SWITCH, dpst	SWT-333	
	C50	0.001µf ± 10%	500dcwv	COM-21B	S3	SWITCH, spdt	SWT-320	
	C51	0.001µf ± 10%	500dcwv	COM-21B	S4	SWITCH	805-426	
	C53	240 ± 10%		COU-10	T1	TRANSFORMER	565-405-2	
	C54	400 ± 10%	300dcwv	COM-20B	V1	TUBE	6L6	
	C55	0.02µf ± 10%	600dcwv	COM-50B	V2	TUBE	6L6	
	C56	0.02µf ± 10%	600dcwv	COM-50B	V3	TUBE	6C8G	
	C57	0.05µf ± 10%	600dcwv	COM-50B	V4	TUBE	6L6	
	C58	100 ± 10%	300dcwv	COM-20B	V5	TUBE	5U4G	
	C59	20 ± 10%	300dcwv	COM-20B	V6	TUBE	2A3	
	C61	100 ± 10%		COU-8-2	V7	TUBE	6SF5	
	C64	40µf		COE-11	V8	TUBE	OD3/VR150	
	C65	300 ± 10%	300dcwv	COM-20B	V9	TUBE	6AL5	
	C66	0.01µf ± 10%	500dcwv	COM-41B	V10	TUBE	Amp 3-4	
	C67	0.001µf ± 10%	500dcwv	COM-30B	V11	TUBE	6H6	
	C68	125 ± 10%	300dcwv	COM-20B	V12	TUBE	2A3	
	C69	0.001µf ± 20%		(NOTE D)	Oscillator Coils		Amplifier Coils	
	C101	0.005µf ± 10%	500dcwv	COM-41B	805-341	A	805-491	
C103	50 ± 10%	300dcwv	COM-20B	805-392-2	B	805-492-2		
C104	200 ± 10%	300dcwv	COM-20B	805-393-2	C	805-493-2		
C105	5 ± 10%	300dcwv	COM-20B	805-394	D	805-494-2		
C109	35 ± 10%	300dcwv	COM-20B	805-395	E	805-495-2		
C112	60 ± 10%	300dcwv	COM-20B	805-398	F	805-498		
C113	500 ± 10%	300dcwv	COM-20B	805-449	G	805-499		
C114	800 ± 10%	300dcwv	COM-20B					
C115	500 ± 10%	300dcwv	COM-20B					
C116	300 ± 10%	300dcwv	COM-20B					

NOTES:

(A) GR Type designations for resistors and capacitors are:

- COA - Capacitor, air
- COE - Capacitor, electrolytic
- COEB - Capacitor, electrolytic block
- COL - Capacitor, oil
- COM - Capacitor, mica
- COU - Capacitor, unclassified
- POSC - Potentiometer
- POSW - Potentiometer
- REC - Resistor, composition
- REF - Resistor, film

- REPO - Resistor, power
- REPR - Resistor, precision
- REW - Resistor, wire-wound

(B) All resistances are in ohms except as otherwise indicated by k (kilohms) or M (megohms).

(C) All capacitances are in micromicrofarads except as otherwise indicated by µf (microfarads).

(D) Part of V9 tube socket.

When ordering replacement components, be sure to include complete description as well as Part Number. (Example: R85, 51k ± 10%, 1/2w, REC-20BF.)

GENERAL RADIO COMPANY
SERVICE AND MAINTENANCE NOTES
FOR THE
TYPE 805-C STANDARD-SIGNAL GENERATOR

1.0 FOREWORD

- 1.1 This Service Information together with the information given in the Operating Instructions should enable the user to locate and correct ordinary difficulties resulting from normal usage. Equipment used in our laboratory to test the generator is listed at the end of the notes.
- 1.2 Most of the components mentioned in these notes can be located by referring to the photographs.
- 1.3 Major service problems should be referred to the Service Department which will cooperate as far as possible by furnishing information and instructions, as well as by shipping any replacement parts which may be required. If the instrument is more than one year old, a reasonable charge may be expected for replacement parts or for complete reconditioning and recalibration if the generator is returned.
- 1.4 Detailed facts giving type and serial numbers of the instrument and parts, as well as operating conditions, should always be included in your report to the Service Department.

2.0 GENERAL

If the generator becomes inoperative, a few simple checks should be made before removing the instrument from the cabinet.

- 2.1 Check power line source.
- 2.2 Test power supply cord for open circuit or poor contact in power outlet.
- 2.3 Check fuses mounted at back of cabinet for open circuits and be sure they are tight in their clips.

3.0 INPUT POWER

- 3.1 Input power, with the range switch on the blank position, is normally 110 watts $\pm 5\%$ where the supply voltage is 115 volts. If the

measured power is higher, test the 5U4G rectifier tube (V-5), the filter condensers, condensers C-23 and C-29 (through the right-hand amplifier partition), and *test the by-pass condensers* for short circuit.

- 3.2 With the range switch set on the different coil ranges and the OSC. PLATE switch on, the normal power input is as follows:

RANGE	A	B	C	D	E	F	G
POWER (watts)	115	122	128	130	135	135	145

- 3.3 High power readings may indicate one or both Type 6L6 Tubes (V-1 and V-2) defective. Examine the chokes L-2 and L-3, which will probably show evidence of overheating in case of a serious short in the oscillator or amplifier circuit.

If the wattage is low and the output voltmeter reads low on some ranges, test for short-circuited trimmer condensers on the oscillator or amplifier turrets. If the wattage is low and there is no output on any range, measure R-1, R-4 and R-56 (gray ceramic-coated resistors).

4.0 GENERATOR INOPERATIVE

- 4.1 See that all tube filaments are lighted. Test also the line filter for open circuit or ground; this is inside the cabinet on the back.
- 4.2 If pilot lamp lights but neither meter operates, see Sections 4.0, 5.0, 6.0, 11.0 and 16.0.
- 4.3 If neither meter reads but the generator does have output, make sure that the Amperite type 3-4 ballast tube V-10 has a faint glow or feels warm. Note that this tube is in series with the filaments of the 6AL5 tube V-9 and the 6H6 voltmeter tube V-11.
- 4.4 If the carrier circuit only is inoperative, see Sections 5.0 through 11.0.
- 4.5 If the modulation circuit only is inoperative, see Sections 12.0 through 15.0.

GENERAL RADIO COMPANY

5.0 NO READING OF OUTPUT VOLTAGE METER ON ANY RANGE

- 5.1 Check the action of all contacts on the coil turret mechanisms. These should operate properly in both directions of the coil turrets. The effect of poor contacts is more evident on F and G ranges.
- 5.2 Measure the output of the oscillator with a vacuum-tube voltmeter across lead from No. 5 terminal and C-5 and ground. The reading should be approximately 20 volts at 16 Mc, 11 volts at 32 Mc, and 9 volts at 50 Mc (G range).
- 5.21 If there is no reading, measure plate and screen voltages of V-1 (see table in Section 26). If there is no voltage in either instance, test for shorts and grounds in plate supply circuit. Also test VM5.
- 5.3 Measure the output of the amplifier with a vacuum-tube voltmeter across output lead connection and ground. The voltmeter should read at least 5 volts on all ranges.
- 5.31 If there is no reading, measure the plate and screen voltages of V-2.
- 5.4 Test V-9 (vacuum-tube voltmeter tube).
- 5.41 Check tube contacts in socket springs.
- 5.5 Check V-10 and V-11. The filaments of these tubes are in series with the filament of V-9. If an open circuit occurs in any one tube, the others are inoperative.
- 5.6 Test the lead through the meter case for a ground.
- 5.7 Defective meter. This should read full scale with 200 microamperes D.C.
- 5.71 If the meter is defective, a replacement should be ordered from the Service Department. The General Radio Company cannot assume responsibility for any local repairs to the meter, although such repairs might be necessary in an emergency.
- 5.8 Test C-14 (amplifier tuning condenser) for grounded rotor.
- 5.81 Test C-23 for breakdown or leakage.

- 5.9 Measure resistance values of R-17, R-21 and R-31 in output voltage meter circuit.
- 5.10 Measure condensers C-24, C-39, C-40 and C-43.
- 5.11 Measure output control (R8a and R8b).
- 5.111 Make certain contacts are properly in place.
- 5.112 Test windings for open circuits.
- 5.113 If contact surfaces of windings are dirty, clean with solution of half ether and half alcohol and wipe off residue with clean cloth. Lubricate surfaces with Liqui-Moly N. V. Grease to prevent undue wearing of contacts. See Section 25.0.
- 5.12 Check R-2 in oscillator and R-6 in amplifier for overheating or open circuits. Such conditions may indicate breakdowns in coils or condensers in either circuit.

6.0 NO READING OF OUTPUT VOLTAGE METER EXCEPT ON "G" RANGE

- 6.1 Measure resistance of R-1.

7.0 NO READING OF OUTPUT VOLTAGE METER ON ONE OR MORE RANGES

- 7.1 Test oscillator and amplifier coils in turrets for open or short circuits.
- 7.2 Check ground connection strap on oscillator turret (E range only). This may have become short circuited to the shaft of the trimmer condenser C-7e.
- 7.3 Test trimmer condensers on inoperative range for ground or short circuits.

8.0 LOW READING OF OUTPUT METER (USUALLY ON "G" RANGE)

- 8.1 Test tubes V-1 and V-2.
- 8.11 If replacement of either is necessary, select a tube with a transconductance of between 4600 and 5000. A tube with a value below 4600 may indicate low output on the meter. See Section 18.0.
- 8.2 Test capacitors C-5 and C-8 for open or short circuit and leakage. Any defect will cause a lowered output at the high end of the G range.
- 8.3 Measure resistors R-1 and R-4.

GENERAL RADIO COMPANY

8.4 Meter sensitivity may have changed. This is most noticeable on the G range.

8.41 To check this, set frequency on D range at 1 Mc. Set attenuator at 1 volt position, measure voltage with a vacuum-tube voltmeter, and if reading is not 1 volt, adjust CAL. ADJ. control on panel.

8.5 Measure plate supply voltage. This should be 290 v. Adjust as necessary using R-28.

8.6 Test capacitor C-12 for leakage.

8.7 Check R-54 to see if resistance has increased above 100 ohms. This is located under the socket at V-2, amplifier section, and is covered by black empire tubing.

8.8 Measure cathode resistors R-1 of V-1 and R-4 of V-2. See Section 3.3.

8.9 Measure R-109, located in oscillator turret, Coil G.

8.10 Make certain that the cam switch S-4 short circuits R-3 on the E, F and G ranges.

9.0 ERRATIC OUTPUT WITH OUTPUT VOLTAGE METER INDICATING NORMALLY

9.1 Refer to Section 10.0 covering 805-P1 Termination Unit and Attenuator.

9.11 Check soldered joint of connector strip between input wire and switch arm in multiplier section of attenuator. This should be resoldered if necessary.

9.12 Be sure that the attenuator switch is making positive contact.

10.0 NO OUTPUT BUT OUTPUT VOLTAGE METER READS

10.1 Type 805-P1 Termination Unit.

10.11 This should be tested for open circuits in the cable and resistors R-201, R-202, and R-203.

10.12 If one or more of the resistors are open, the voltage at the termination unit will be twice that indicated by the OUTPUT VOLTAGE meter if the termination switch is on NORMAL. A Type

805-337 Switch Plate and Contact Assembly containing these three resistors may be ordered from the Service Department. It is suggested that the defective assembly be returned for repairs and kept as a spare. After replacing a Type 805-337-2 Switch Plate, readjust the calibration of the OUTPUT VOLTAGE meter. See Section 22.0.

10.13 *Caution:* Never coil the output cable tightly because the center conductor may break.

10.2 If a check shows voltage at the input to the attenuator but no output at any setting, measure resistor R-123. This is located directly behind the panel jack and can be measured with the Leeds and Northrup bridge after the small circular plug has been pried out of the rear of the casting. *Caution:* The current through R-123 must not exceed 50 milliamperes.

10.21 R-123 may be removed by unsoldering the rear connection and unscrewing the large hex nut on the panel jack. The large hex nut will expose a center "banana" plug, mounted upon an insulating disc, which is retained by a threaded ring. The latter has two slots, which will enable it to be turned counter-clockwise, for removal. Lift out the "banana" plug and mounting disc; R-123 will be found soldered to a terminal lug under the disc. Re-assemble the unit in the reverse order.

10.3 Check the attenuator by connecting the Leeds and Northrup bridge across the panel jack. If all switch positions except the 1-volt do not give a 75-ohm reading, remove the large cover on the rear of the attenuator casting and measure the resistance cards. On the 1-volt position, the resistance should measure 475 ohms when the CARRIER FREQUENCY RANGE is on the blank position.

10.4 With the output cable removed, the voltage at the panel jack, as measured with a Type 1800 Vacuum-Tube Voltmeter or equivalent, should be approximately twice that indicated by the OUTPUT VOLTAGE meter.

GENERAL RADIO COMPANY

11.0 ERRATIC OPERATION OF OUTPUT VOLTAGE METER

- 11.1 Poor contacts in turret switches — this is most evident on F and G ranges.
- 11.11* When the turret contact springs (mounted on condenser) are replaced make certain that the metal washer $\frac{1}{2}$ " dia., .020" thick, clearance hole for No. 6 machine screw is placed under each spring to prevent it from sinking into the polystyrene base when the terminals are soldered.
- 11.2 Poor contacts in OUTPUT VOLTAGE control (R-8a and R-8b).
- 11.21* Clean and lubricate. See Section 24.0.
- 11.3 Test V-1 and V-2.
- 11.4 Check vacuum-tube voltmeter circuit. See Sections 5.3 to 5.10 inclusive.
- 11.5 Poor contact of rotor brush contacts in both oscillator and amplifier tuning condensers, C-6 and C-14.
- 11.51* To clean contact discs and brushes, remove bottom pan. Clean with solution of half ether and half alcohol, and wipe off residue with clean cloth. Apply a very thin layer of Liqui-Moly N. V. Grease.
- 11.52* *Caution:* The condensers operate at almost 290 volts above ground. The small cup contacts at each end of the condenser rotors should *not* be lubricated.
- 11.6 Check insulating bushings of C-5 for cracks or looseness, especially if operation is erratic in G range only.
- 11.7 Check the fixed grounding contacts to make certain that they short circuit adjacent coil.
- 11.8 Check voltage regulator circuit. See Section 17.0.
- 11.9 If high zero reading of the OUTPUT VOLTAGE meter cannot be corrected by the adjustment ZERO ADJ., look for an open circuit in R-18 or R-20 potentiometer.

12.0 INOPERATIVE MODULATION METER

- 12.1 If PERCENTAGE MODULATION meter

does not operate on either 400 or 1000 cycles, check the setting of the corresponding panel adjustment beside the PERCENTAGE MODULATION control. These adjustments should be turned clockwise until the circuit just oscillates or until the meter can be set to 100% on the G range. A higher setting will increase the harmonic content of the audio output.

- 12.2 If PERCENTAGE MODULATION meter does not indicate when modulation is turned on, test for modulation on the carrier output by means of a radio receiver or a cathode-ray oscillograph.
- 12.3 If the output is properly modulated while the meter reads zero, see that the filament of V-10 (Type 3-4) is normal. Measure resistors R-32, -33, -47, and -60, and condensers C-28, -41, and -44. This may be more easily done by removal of side pan. If the meter itself is inoperative this should be returned to the Service Department for repairs. See Section 5.71. Try a new V-11 (6H6) tube.
- 12.4 If no modulation is obtained in any position of S-1, set this switch to 400 cycles and check with phones between terminal No. 5 of V-4 (6L6) and ground. If the 400-cycle tone is heard, try a new 6L6 tube and check condenser C-37.
- 12.5 If no tone appears at the V-4 grid, connect the phones between ground and the grid cap of V-3 (638G). If no tone is heard at this point, try a new 6C8G tube (V-3). Measure the potentiometer R-38. Measure the voltages on V-3 and V-4. See tube data in Section 26.0.

13.0 MODULATION METER READS ON SOME SETTINGS

- 13.1 If normal modulation is obtained on both internal ranges but not when audio voltage is applied to the EXT. MODULATION terminals, see that an ohmmeter shows open circuit between these terminals. Check the contacts on switch located on oscillator turret gear.
- 13.2 If the external modulation and the 400-cycle internal modulation are normal but the 1000-cycle internal modulation does not operate, check contacts on switch S-1. Measure also resistors R-13 R-14 and R-16 and the potentiometer R-15. These are more easily accessible if the end pan is removed.

GENERAL RADIO COMPANY

- 13.3 If the external modulation and the 1000-cycle internal modulation are normal, but the 400-cycle internal modulation does not operate, check the contacts on PERCENTAGE MODULATION switch. Measure also resistors R-9, R-10, R-12, and R-35, and the potentiometer R-11. These are more easily accessible if the end pan is removed.
- 13.4 If the external modulation is normal but neither 400-cycle nor 1000-cycle internal will operate, try a new V-3 (6C8G) tube. Test condensers C-18, -19, -20, -32, -33, and -59. These are more easily accessible if the end pan is removed.
- 13.5 The meter and its circuit were designed to read correctly using modulation frequencies up to about 15 kc. The low end of the A range on the generator goes down to about 16 kc or slightly lower, and it is not practicable to design and manufacture a filter for the meter circuit which would pass all of the 15 kc and cut off all of the 16 kc, hence the response on the A-B ranges is limited to 1000 cycles.

14.0 LOW MODULATION METER READINGS

- 14.1 In case of low output from the modulating system, try new tubes in the V-3 and V-4 sockets. Measure the tube voltages in accordance with the tube data given under Paragraph 18.0
- 14.2 Measure resistors R-34, R-35, R-37, R-41 and R-42, and also condensers C-33, C-37 and C-47.
- 14.3 Check the panel trimmers to see if they are set too fine. See Section 12.1.

15.0 ERRATIC OPERATION OF MODULATION METER

- 15.1 See that the PERCENTAGE MODULATION potentiometer R-38 is clean and is making reliable contact. Check also the contacts on turret switch and try new tubes in the V-3 and V-4 positions (6C8G and 6L6).

16.0 HUM MODULATION ON CARRIER

- 16.1 This condition might be caused by the receiver under test having an excessive amount of hum in its power supply or pickup from external fields by the receiver itself. An unshielded lead, if used between the generator and the receiver, might also cause 60-cycle pickup. Although the

output impedance is very low (37.5 ohms), care should be taken to see that the high lead is kept short. This hum may also appear as a frequency modulation if the whole instrument is vibrated at 60 cycles or some other frequency, because of the transmission of the mechanical vibration to the main tuning condenser plates.

- 16.2 In testing radio receivers, make certain to ground only the generator in order to avoid circulating currents in the ground lead. The receiver will automatically be grounded when connected to the generator through the shielded lead. Isolate line-connected AC-DC types of receivers with a small series condenser.
- 16.3 If the receiver cannot be grounded because of design considerations, connect the generator to ground through a .02-microfarad condenser.
- 16.4 If the output of the generator is too high, the receiver will be overloaded, causing the tubes to become microphonic and resulting in what might be mistaken for hum modulation of the generator carrier.
- 16.5 Hum may also be caused by open circuit in condensers C-4, C-4A, C-25, C-26 or C-38. These should be checked.
- 16.6 Select rectifier (V5) and regulator tubes (V6, V7, V8) that give satisfactory operation in the circuit. See Section 17.0.

17.0 VOLTAGE REGULATOR AND POWER SUPPLY

- 17.1 The d-c voltage regulator on the plate voltage supply will maintain a value of 290 volts $\pm 1\%$ over a range of line voltage variations from 105 to 125 volts.
- 17.2 To measure the d-c voltage, connect any 1000-ohms-per-volt meter from ground to terminal No. 1 of the choke coil L-5 (upper right-hand shelf, viewed from rear). Adjust the potentiometer R-28 for a meter reading of 290 volts.
- 17.3 Failure of R-28 to change the d-c voltage could be caused by an open circuit in R-27, R-28 or R-29. The voltage will remain high if R-27 is open, low if R-29 is open, and either high

GENERAL RADIO COMPANY

or low depending upon the setting of the blade if R-28 is open.

- 17.4 If tube V-8 (0D3/VR150) does not light with the usual purple glow, test resistor R-25 for an open circuit. If this is not open, try a new V-8 tube.
- 17.5 If V-8 glows normally but the d-c voltage varies with changes in the line voltage, try a new Type 6SF5 Tube (V-7).
- 17.6 If the new V-7 tube affords no improvement, try new Type 2A3 Tubes. No selection is necessary for any of these power-supply tubes as long as the new tubes are normal.
- 17.7 If not power at all is obtained from the plate supply, try replacing the V-5 rectifier tube (Type 5T4) or 5U4G

18.0 TUBE DATA AND TUBE REPLACEMENTS

- 18.1 Most of the tubes in the Type 805-C can be replaced without special selection or adjustment. These include the amplifier tube V-3, the modulation amplifier tube V-4, the power-rectifier tube, V-5, the plate voltage regulator tubes V-6, V-7 and V-8, the ballast tube V-10, the modulation voltmeter tube V-11, and the voltage regulator tube V-12.
- 18.2 Replacement of the oscillator tube V-1 makes no difference on the lower ranges but may cause some slight change in frequency at the high-frequency end of the 50-megacycle band. The 50-megacycle point should be checked to see if adjustment is necessary. Watch for motor-boat oscillations in some of these tubes at or near 50 megacycles
- 18.3 In order to readjust the upper part of the G range, an adjustment must be made in the air-trimmer condenser C-7a. With the coil operating, take a long screw driver with a small tip and an insulated shaft and insert it through the hole in the panel which is uncovered by removing the upper one of the two snap buttons to the right of the main frequency dial. When the screw driver has been inserted in the screw-driver slot of the air trimmer condenser, it may be turned very slightly in one direction or the other in order to readjust this calibration. See Section 19.0.
- 18.4 If the modulation oscillator tube V-3 is replaced, it will be necessary only to check the

400-cycle and 1000-cycle modulation frequency in accordance with Section 12.1.

- 18.5 When replacing tube V-9 for the OUTPUT VOLTAGE meter, measure the voltage at the termination of the output cable with a Type 1800 Vacuum-Tube Voltmeter. This tube must be selected both for calibration agreement with the 1800 and for electrical zero. When a tube has been selected which agrees in calibration with the voltage as measured on the Type 1800 Vacuum-Tube Voltmeter at the termination unit on the end of the output cable, it should be allowed to operate for several hours. The electrical ZERO ADJUSTMENT R-20 should then be set and the calibration again checked against the 1800. If the calibration then remains normal, there is not much likelihood that the tube characteristics will change after this first several hours of aging.

19.0 REMOVAL OF TURRETS

To clean thoroughly or to readjust the selector switch blades it may be desirable to remove the coil turrets.

- 19.1 Remove the instrument from the cabinet.
- 19.2 Remove the cover to the r-f compartment.
- 19.3 Remove the Type 6L6 Tubes after marking them so they will not be interchanged.
- 19.4 Remove the heat shield between the oscillator tube and the oscillator coil turret.

Note the setting of the RANGE SELECTOR switch and the positions of the turrets. They can then be taken out as soon as the three screws at each hub have been removed.
- 19.5 Replacement of the turrets is accomplished in the reverse order.

20.0 FREQUENCY CALIBRATION OF CARRIER

- 20.1 If an accurately known standard and means of comparing frequencies are available, the procedure is quite simple.
- 20.2 Remove the upper snap button located to the right of the main dial. The small screw head accessible through the exposed hole is the air trimmer adjustment for the range shown on the CARRIER FREQUENCY RANGE dial.
- 20.3 Remove the lower snap button located to the right of the main dial. Within this hole is the

GENERAL RADIO COMPANY

head of the screw which turns the dust core in or out of the coil. **CAUTION:** High voltage appears between the condenser adjustment and the panel, necessitating the use of a screw driver with the shank insulated by a piece of Empire tubing (spaghetti). The point should be ground fine and flat since a thick point may break the head of the coil screws.

- 20.4** Increasing the inductance will decrease the frequency at the low end of each range with little effect on the high end. Increasing the capacitance of the trimmer condensers will decrease the frequency of the high end of each range with little effect at the low end.
- 20.5** Similar adjustments for the amplifier are found under the snap buttons located beneath the cover of the CARRIER FREQUENCY RANGE dial. These are exposed by removing the three screws and the cover. These are tuned to give a maximum output on each range. The adjustment is not critical and trimmer condensers are not provided on the A, B, and C ranges.

21.0 CALIBRATION OF PERCENTAGE MODULATION METER

- 21.1** The PERCENTAGE MODULATION meter indications may be checked against a cathode-ray oscillograph or any precise means of measuring modulation such as the GR Type 1931-A Modulation Monitor preceded by a linear amplifier.
- 21.2** With the 805-C controls set to 1 Mc the OSC. PLATE switch should be snapped OFF and the PERCENTAGE MODULATION meter should be set to zero by means of its mechanical zero adjustment. With the OSC. PLATE switch on and the MODULATION switch set to 1000, the 30%, 50% and 80% points should be measured. These points should all be correct to within $\pm 10\%$ of the meter reading, and any errors should be corrected by changing resistor R-104 which is located under the snap button above and to the right of the main dial.
- 21.3** The other ranges should be similarly checked, but the zero setting of the meter must not be changed from the setting made at 1 Mc. (Note also that the accuracy on the G range is 15% of the meter reading.) Adjustments are made by changing the individual resistors which are

switched into position by the RANGE SELECTOR switch.

22.0 ADJUSTMENT OF OUTPUT VOLTAGE METER

- 22.1** Zero adjustment.
- 22.11** Set the mechanical adjustment to zero with the power turned off. Turn the power on and set the control marked ZERO ADJ. after the instrument has been warmed up and with the RANGE SELECTOR on the D range and the OSC. PLATE switch off.
- 22.2** Sensitivity (1 volt)
- 22.21** With the Type 805-P1 Termination Unit connected to the output jack, place the probe of a Type 1800 Vacuum-Tube Voltmeter directly against the terminals DIRECT and G of the termination unit with the switch set to NORMAL.
- 22.22** With the modulation switch turned off, the RANGE SELECTOR set to D, and the MULTIPLY BY switch set to 1 volt, the OUTPUT VOLTAGE control should be turned up until the Type 1800 Voltmeter indicates 1 volt.
- 22.23** Adjust the CAL. ADJ. until the OUTPUT VOLTAGE meter indicates 1 volt.
- 22.24** If the CAL. ADJ. control has insufficient range for this adjustment, try a new V-9 Tube. Changing the CAL. ADJ. potentiometer may require a resetting of the ZERO ADJ. (Section 22.11). Both settings should be re-balanced until they are correct.

23.0 MODULATION VTVM FREQUENCY CHARACTERISTIC

- 23.1** With the RANGE SELECTOR set to the blank position between coils C and A and the modulation switch set at EXT., a Type 1304-B Oscillator should be connected to the EXTERNAL MOD. terminals.
- 23.2** Turn the PERCENTAGE MODULATION control full clockwise, set the Type 1304-B at 1000 cycles, and set its output control to give

GENERAL RADIO COMPANY

a reading of 80% on the PERCENTAGE MODULATION meter.

23.3 Change the frequency dial of the Type 1304-B from 1000 cycles down to 50 cycles, and from there to 15,000 cycles, noting the readings of the PERCENTAGE MODULATION meter. This should stay within 1 division of its setting at 1000 cycles.

23.4 If the meter is not linear over this range, it

would be advisable to try new V-11 (6H6), V-4 (6L6), or V-3 (6C8G) Tubes. The condenser C-68 should also be measured, and it may be advisable to change this to a different value, somewhere between 110 and 145 μf .

24.0 CONTINUITY CHECK

24.1 The oscillator turret can be tested for continuity with an ohmmeter as follows. (Terminal numbering shown in Figure 4, page 4.)

TERMINALS

Coil	1 and 3	2 and 4	3 and 2	5 and gnd. strap
A	750 K ohms $\pm 10\%$	200 ohms $\pm 10\%$	Open	25 K ohms $\pm 10\%$
B	0 ohms	60 ohms $\pm 10\%$	Open	50 K ohms $\pm 10\%$
C	0 ohms	10 ohms $\pm 20\%$	Open	20 K ohms $\pm 10\%$
D	0 ohms	2 ohms $\pm 10\%$	Open	25 K ohms $\pm 10\%$
E	0 ohms	0 ohms	Open	40 ohms $\pm 10\%$
F	2500 ohms $\pm 10\%$	0 ohms	Open	40 ohms $\pm 10\%$
G	5000 ohms $\pm 10\%$	0 ohms	Open	Terminals 5 and 6 0 ohms

24.2 The amplifier turret may be checked for continuity for the following. (Use Weston

Ohmmeter; Terminal numbering shown in Figure 4.)

TERMINALS

Coil	1 and 3	2 and 4	2 and 3	6 and gnd. strap	6 and 4
A	20 ohms $\pm 10\%$	250 ohms $\pm 10\%$	Open	10 K ohms $\pm 10\%$	Open
B	10 ohms $\pm 10\%$	500 ohms $\pm 10\%$	Open	20 K ohms $\pm 10\%$	Open
C	0 ohms	7.5 ohms $\pm 10\%$	Open	Open	Open
D	0 ohms	2 ohms $\pm 10\%$	Open	Open	0 ohms
E	0 ohms	0 ohms	Open	Open	50 K ohms $\pm 10\%$
F	0 ohms	0 ohms	Open	Open	Open
G	0 ohms	0 ohms	Open	Open	Open

25.0 LUBRICATION

25.1 The CARRIER FREQUENCY INCREMENT dial rotates on a steel shaft and bushing. Removal of this dial by loosening the two setscrews will expose an oil hole in the end of the shaft. A few drops of machine oil per year will provide adequate lubrication.

25.2 All gears associated with the coil changing mechanism, the dial drive and the contact surfaces of the OUTPUT VOLTAGE control, and all potentiometers and rheostats should be lubricated with Liqui-Moly N. V. Grease (obtainable from the Lockrey Company, College Point, N. Y.).

GENERAL RADIO COMPANY

26.0 VACUUM TUBE DATA

Table of tube socket voltages measured from socket

pin to ground using a 20,000 ohm per volt meter (Weston 772 Analyzer). D.C. voltages except as noted might vary $\pm 20\%$.

TUBE (TYPE)	PIN NO.	*FREQ RANGE	VOLTS TO GND	TUBE (TYPE)	PIN NO.	*FREQ RANGE	VOLTS TO GND	TUBE (TYPE)	PIN NO.	*FREQ RANGE	VOLTS TO GND	TUBE (TYPE)	PIN NO.	VOLTS TO GND
V1 (6L6) R-F OSC	1		0	V1 (cont.)		E	9.2	V2 (cont.)		B	12.2	V6 (cont.)	4	295
	2		6.3AC			F	7.05			C	19.8		V7 (6SF5) REG	1-4
	3	A	293			G	0			D	35.5	1		0
		B	291	V2 (6L6) R-F AMP	1		0			E	32.5	2		152
		C	290		2		6.3AC			F	22.5	3	146	
		D	292		3	A	268		G	23.8	5	265		
		E	290			B	251	V3 (6C8) AUDIO OSC	1		0	V8 (0D3) REG	2	0
		F	288			C	248		2	6.5AC	5		152	
		G	282			D	218		3	160				
		A	57			E	222		4	3.6	V9 (6AL5) CARRIER VTVM	1	0	
		B	46			F	243		5	0		3	0	
		C	69.5			G	240		6	155		4	6.5AC	
		D	14.2		4	A	42		7	0				
		E	19.5			B	71.5		8	3.7		2	15.2AC	
		F	40			C	155	V4 (6L6) MOD	1		0	V10 (AMP 3-4) REG	7	6.5AC
		G	67			D	220		2	6.5AC				
		A	-9.2			E	183		3	280	V11 (6H6) MOD VTVM	1	0	
		B	0			F	183		4	215		2	15.2AC	
		C	0			G	180		5	0		3	-0.32	
		D	0		5	A	-0.38		7	0		4	0	
		E	0			B	-4.8		8	11.5		5	-0.32	
		F	-4.5			C	0		V5 (5U4G or 5T4) RECT	2		455	V12 (2A3) REG	1
		G	-16.5			D	0	4		555AC	2	440		
		A	0			E	0	6		555AC	3	265		
	B	3.0			F	0	8	455		4	295			
	C	4.35			G	0	2-8	5.05AC		1-4	2.25AC			
	D	4.1		7	A	5.85	V6 (2A3) REG	1			295			
				8				2		440				
								3		265				

NOTES

All voltages measured from pin to ground (except where otherwise indicated) with 20,000 ohm/volt meter. Frequency set at 1 Mc except where frequency range position is specified. D-c voltages may vary by $\pm 20\%$.

*Where frequency range is indicated, the middle of the range is used:

A - 30 kc C - 300 kc E - 3 Mc G - 30 Mc
B - 100 kc D - 1 Mc F - 10 Mc

GENERAL RADIO COMPANY

REMOVE FOR
ACCESS TO THE
OUTPUT ATTENUATOR

REMOVE FOR ACCESS TO THE
RF OSCILLATOR AND
RF AMPLIFIER

REMOVE FOR ACCESS TO
AF OSCILLATOR AND
POWER SUPPLY

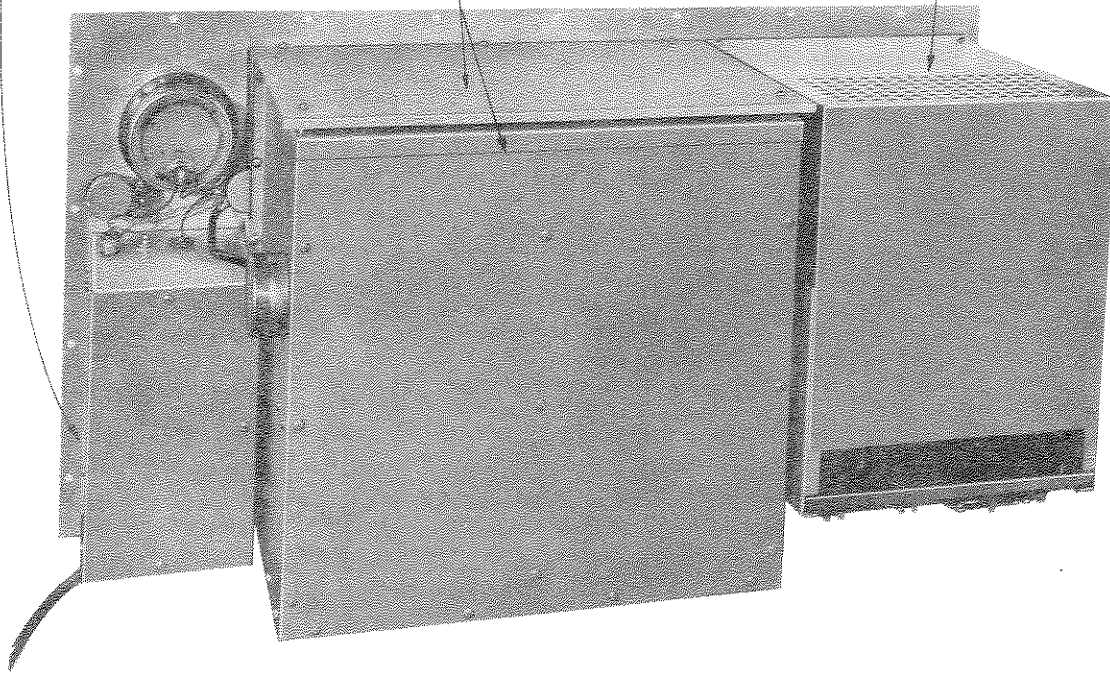

FIGURE 12. REAR VIEW WITH CABINET REMOVED SHOWING POSITION OF SHIELDS.

GENERAL RADIO COMPANY

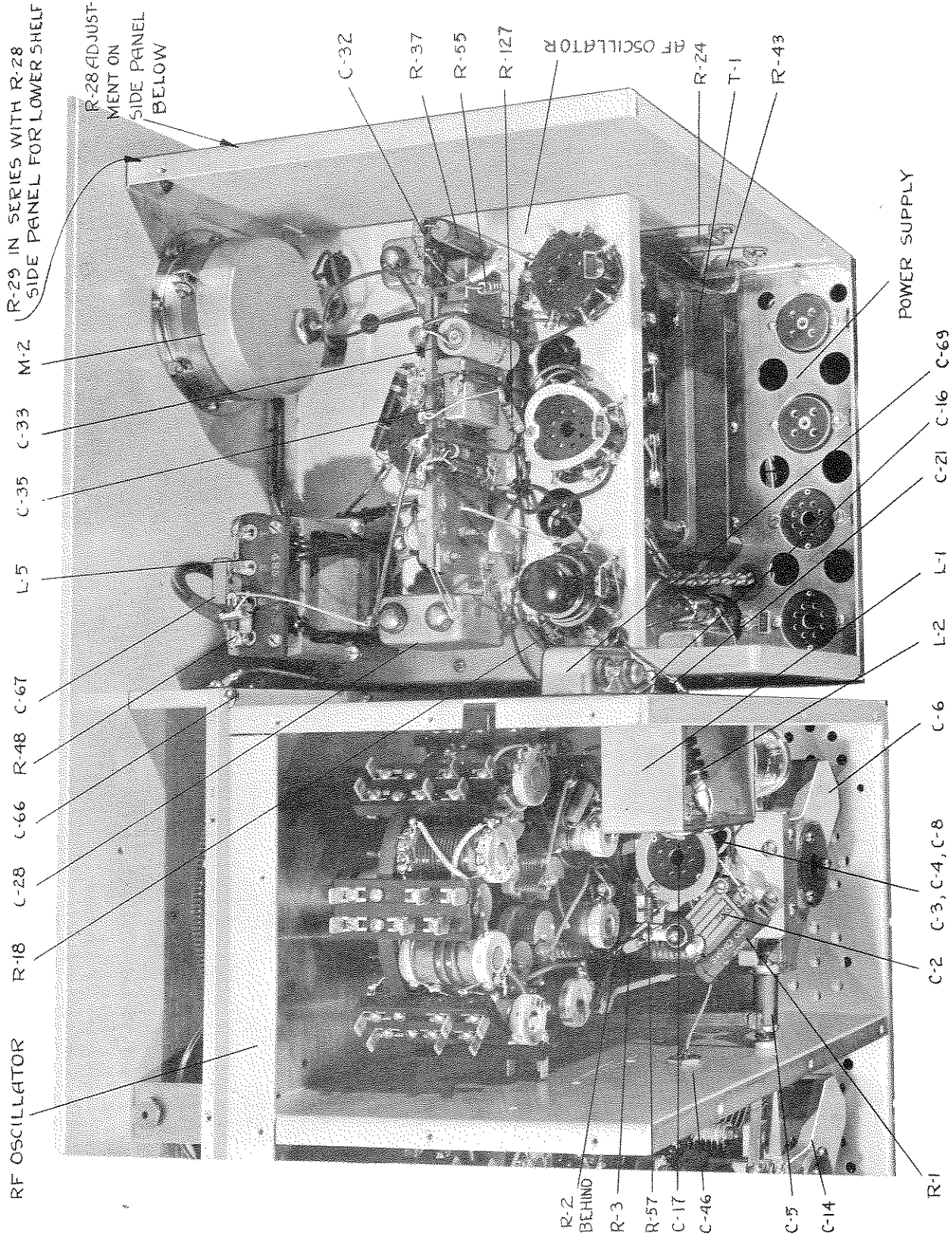

FIGURE 13. VIEW OF POWER SUPPLY AND CARRIER OSCILLATOR WITH PARTS IDENTIFICATION.

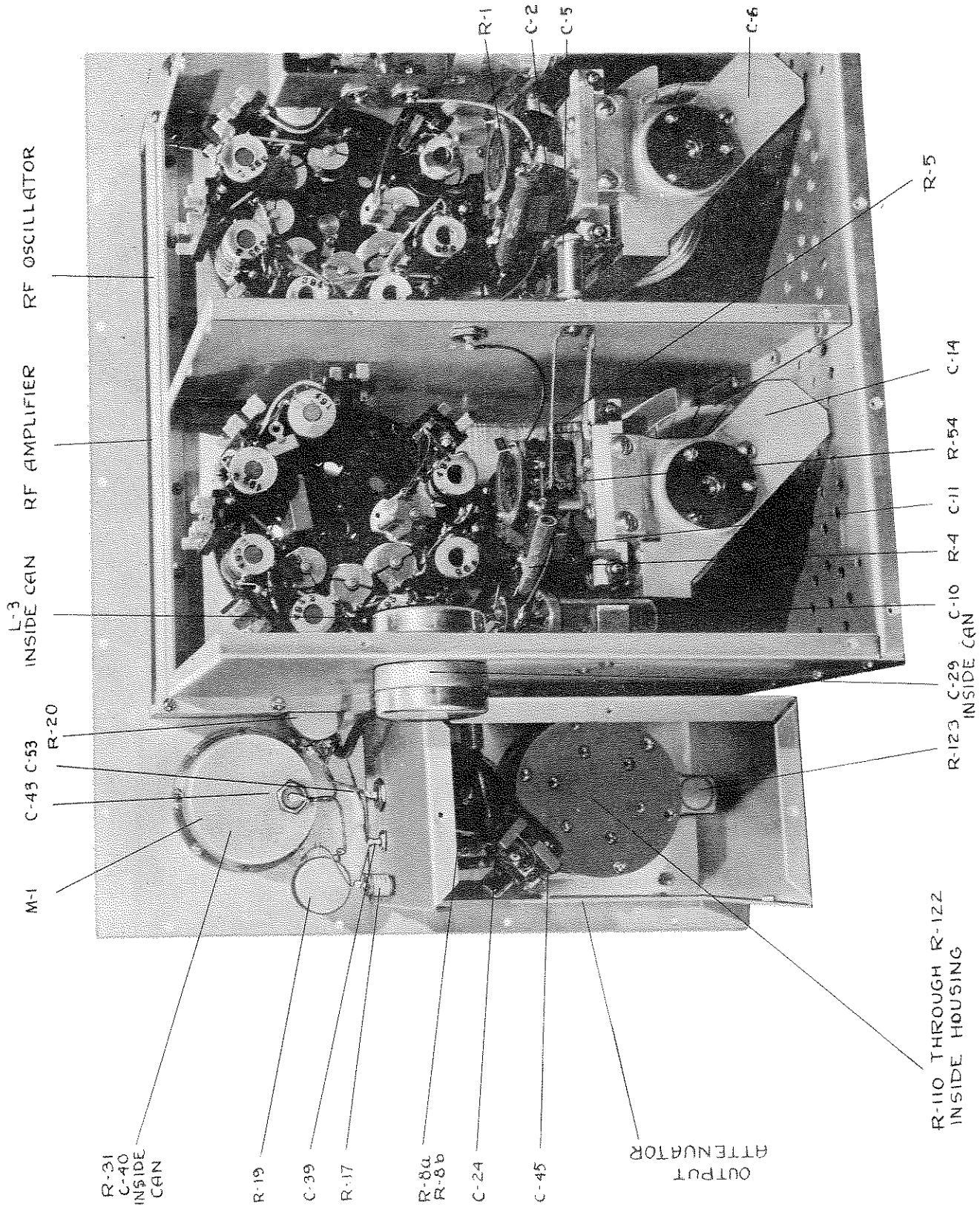

FIGURE 14. VIEW OF R-F AMPLIFIER AND OUTPUT SYSTEM WITH PARTS IDENTIFICATION.