

# INSTRUCTION MANUAL

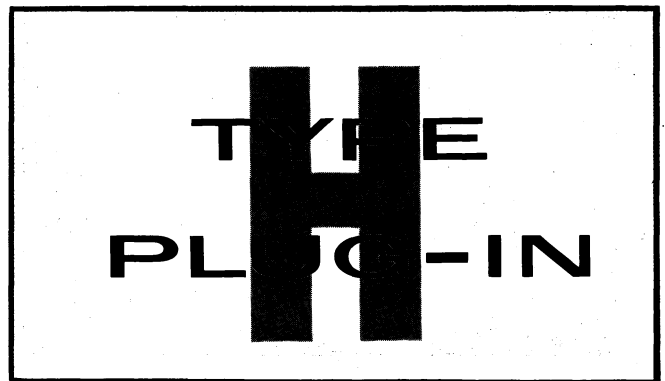

SN 13877

**Tektronix, Inc.**

S.W. Millikan Way ● P. O. Box 500 ● Beaverton, Oregon ● Phone MI 4-0161 ● Cables: Tektronix

**Tektronix International A.G.**

Terrassenweg 1A ● Zug, Switzerland ● PH. 042-49192 ● Cable: Tekintag, Zug Switzerland ● Telex 53.574

070-272



## **WARRANTY**

All Tektronix instruments are warranted against defective materials and workmanship for one year. Tektronix transformers, manufactured in our own plant, are warranted for the life of the instrument.

Any questions with respect to the warranty mentioned above should be taken up with your Tektronix Field Engineer.

Tektronix repair and replacement-part service is geared directly to the field, therefore all requests for repairs and replacement parts should be directed to the Tektronix Field Office or Representative in your area. This procedure will assure you the fastest possible service. Please include the instrument Type and Serial number with all requests for parts or service.

Specifications and price change privileges reserved.

Copyright © 1961 by Tektronix, Inc., Beaverton, Oregon. Printed in the United States of America. All rights reserved. Contents of this publication may not be reproduced in any form without permission of the copyright owner.

TYPE D, E, H, 122, 1121 and 519

IMPORTANT

Before operating this instrument, be sure to remove the plastic shipping clamps from the shock mounts of the amplifier chassis. These clamps should be saved and reinstalled as shown in the sketch if the instrument is to be shipped. Be sure the tongue is inserted next to the chassis to prevent damage to the shock mount.

The clamp should be on the same side of the shock mount as the nut.

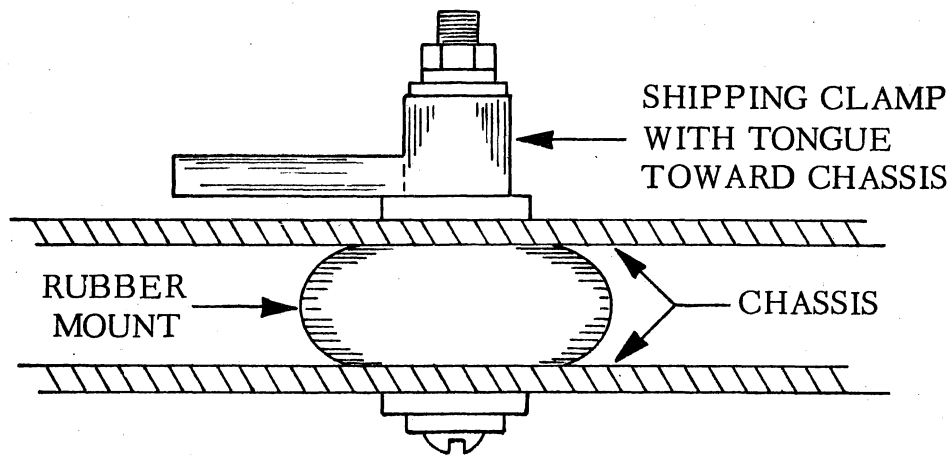



## CONTENTS

Warranty

Section 1 Specifications

Section 2 Operating Instructions

Section 3 Circuit Description

Section 4 Maintenance

Section 5 Calibration Procedure

Section 6 Accessories

Section 7 Parts List and Schematic Diagrams





Type H

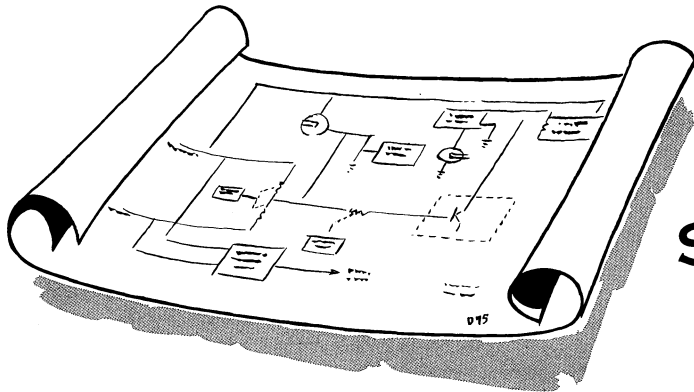

SPECIFICATIONS

The Type H Plug-In Unit is a dc-coupled, high gain, wide-band, calibrated preamplifier, designed for use with Tektronix 530-, 540-, and 550 Series oscilloscopes.

TRANSIENT RESPONSE AND PASSBAND

With Instrument Type	Risetime	Passband	
	INPUT SELECTOR switch in any position	INPUT SELECTOR switch in either DC position	INPUT SELECTOR switch in either AC position
541/541A 543/543A 545/545A 555	.023 $\mu$ sec	DC to 15 Mc	2 cps to 15 Mc .2 cps to 15 MC with P410 Probe or P6000 Probe
551	.025 $\mu$ sec	DC to 14 Mc	2 cps to 14 Mc .2 cps to 14 MC with P410 Probe or P6000 Probe
531/531A 533/533A 535/535A	.031 $\mu$ sec	DC to 11 Mc	2 cps to 11 Mc .2 cps to 11 Mc with P410 Probe or P6000 Probe
536	.037 $\mu$ sec	DC to 9.5 Mc	2 cps to 9.5 Mc .2 cps to 9.5 Mc with P410 Probe or P6000 Probe
532	.07 $\mu$ sec	DC to 5 Mc	2 cps to 5 Mc .2 cps to 5 mc with P410 Probe or P6000 Probe

Your instrument was adjusted at the factory for optimum transient response. The above table summarizes the risetime and approximate passbands available when the plug-in is used in combination with various oscilloscopes.

## Deflection Factor

.005 v/cm to 20 v/cm, in twelve fixed calibrated steps.

.005 v/cm to 50 v/cm, continuously variable.

## Step Attenuator (VOLTS/CM Switch)

A front-panel adjustment is provided for setting the gain of the amplifier. When this adjustment is accurately set, with the VOLTS/CM switch in the .005 position, the vertical-deflection factor for any other position of the switch will be within 3% of the panel reading for that position.

## Maximum Allowable Combined DC and Peak AC Input

Voltage: 600 v.

## Input Characteristics

Input of plug-in unit: 1 megohm shunted by 47  $\mu\mu\text{f}$ .

Input of Type P6000 Probe: 10 megohm shunted by 11.5  $\mu\mu\text{f}$ .

Input of Type P6017 Probe: 10 megohm shunted by 14  $\mu\mu\text{f}$ .

Input of Type P410 Probe: 10 megohm shunted by 8  $\mu\mu\text{f}$ .

## Mechanical

Construction: Aluminum-alloy chassis.

Finish: Photoetched, anodized panel.

Weight: 3 1/2 lbs.

## Front-Panel Controls

THE GAIN ADJ. CONTROL is a screwdriver front-panel control for setting the gain of the plug-in unit and thereby the calibration of the VOLTS/CM switch.

THE INPUT SELECTOR SWITCH is a 4-position switch to select AC or DC coupling from either input connector.

THE INPUT CONNECTORS (Input A, Input B,) coaxial connections for accepting waveforms to be displayed on the oscilloscope screen.

THE DC BALANCE CONTROLS (COARSE and FINE) are front-panel screwdriver controls to be adjusted by the operator to prevent a vertical shift in the crt displays when the VARIABLE CONTROL is rotated.

THE VERTICAL POSITION CONTROL is used to position the trace vertically on the face of the oscilloscope screen.

THE VOLTS/CM SWITCH provides fixed calibrated vertical-deflection factors when the associated VARIABLE control is set to CALIBRATED. The VARIABLE control provides continuously variable (uncalibrated) vertical deflection factors between those provided on the VOLTS/CM switch.

## Accessories

2-Instruction Manuals.

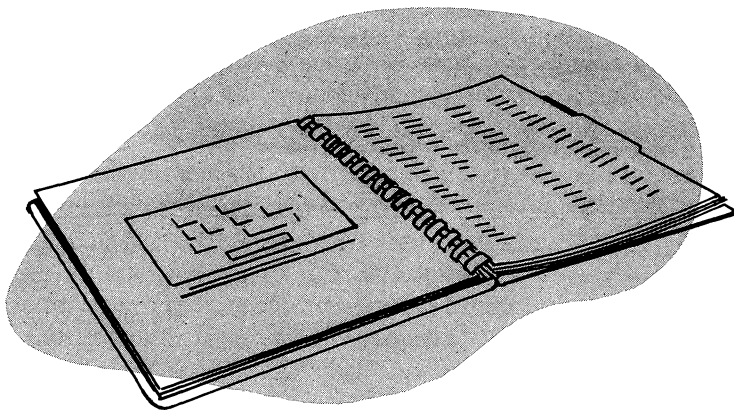

## SECTION 2

# OPERATING INSTRUCTIONS

The Type H Plug-In Unit is designed to operate as a preamplifier for Tektronix 530-, 580-, 540-, and 550-Series Oscilloscopes.

Such factors as tube aging or handling in shipment can result in a need for readjusting the DC Balance and Gain adjustments of the Type H Preamplifier unit. This can be important when you are making amplitude measurements. We suggest that you check these adjustments when first putting your unit into operation, and periodically thereafter. The adjustment procedures are explained in a later section of these operating instructions.

### Input Coupling

The waveform to be examined may be either ac- or dc-coupled to the oscilloscope. To display both the ac component and the dc component of the waveform, set the INPUT SELECTOR switch to the DC position (for the input connector being used); to display only the ac component of the waveform, set the INPUT SELECTOR switch to the AC position (for the input connector being used).

### Deflection Factor

The VOLTS/CM switch controls the vertical deflection factor in accurately calibrated steps. The VARIABLE control provides continuous adjustment of the deflection factor.

NOTE: To make the deflection factor equal to that indicated by the VOLTS/CM switch, set the VARIABLE control to the CALIBRATED position.

### Connecting the Oscilloscope to the Signal Source

Here are some precautions you should observe in connecting your oscilloscope to the source of signals to be displayed.

1. Avoid errors in readings due to stray electric or magnetic coupling between circuits, particularly in the leads connected to the plug-in input circuits. In general, unshielded leads of appreciable length are unsuited to this use. This is true even in the audio-frequency range, except possibly at very low frequencies. (For example, a lead which passes near the crt screen might pick up ripple from the high-voltage supply.) When shielded leads are used, the shields should be grounded to the oscilloscope chassis and to the chassis of the equipment being tested. Coaxial cables are recommended for many purposes.

2. In broadband applications, it might be necessary to terminate a coaxial cable with a resistor or an attenuating pad presenting a resistance equal to the characteristic impedance of the cable. This is to prevent resonance effects and ringing--that is, high-frequency damped oscillation. It becomes more necessary to terminate the cable properly as the length of the cable is increased. The termination is generally placed at the oscilloscope end of the cable, although many sources require an additional termination at the source end of the cable as well.

3. As nearly as possible, simulate actual operating conditions in the equipment being tested. For example, the equipment should work into a load impedance equal to that which it will see in actual use.

4. Consider the effect of loading upon the signal source due to the input circuit of the plug-in preamplifier. The input circuit can be represented by a resistance of 1 megohm shunted by a capacitance of  $47 \mu\mu\text{f}$ . In some cases, the effects of these resistive and capacitive loads are not negligible, and to minimize them, you might want to use a probe in the manner described in the next section.

## Use of Probes

An attenuator probe lessens both capacitive and resistive loading, at the same time reducing sensitivity. When making amplitude measurements with an attenuator probe, be sure to multiply the observed amplitude by the attenuation of the probe (marked on probe).

A Type P6000 Probe is available for use with the Type H Plug-In Preamplifier. Connected to the INPUT connector of the Type H, the probe presents an input characteristic of 10 megohms shunted by 11.5 picofarads and has an attenuation ratio of 10:1. The maximum voltage which may be applied to the probe is 600 volts. Exceeding this rating, either in peak ac volts or dc volts, may result in damage to the components inside the probe body.

If the waveform being displayed contains fast changing portions, it is generally necessary to clip the probe lead to the chassis of the equipment being tested. Select a ground point near the probe-input connection.

Before using the probe, always check its adjustment.

An adjustable capacitor in the probe body compensates for variations in input capacitance from one instrument to another. To insure the accuracy of pulse and transient measurements, this adjustment should be checked frequently.

To make this adjustment, set the calibrator control for a calibrator output signal of suitable amplitude. Touch the probe tip to the CAL. OUT connector and adjust the oscilloscope controls to display several cycles of the waveform. Unlock the probe Locking Sleeve, adjust the Adjusting Sleeve for a flat top on the displayed waveform as shown in Fig. 2-1. When you have completed the adjustment, tighten the Locking Sleeve, being careful not to disturb the setting of the Adjusting Sleeve.

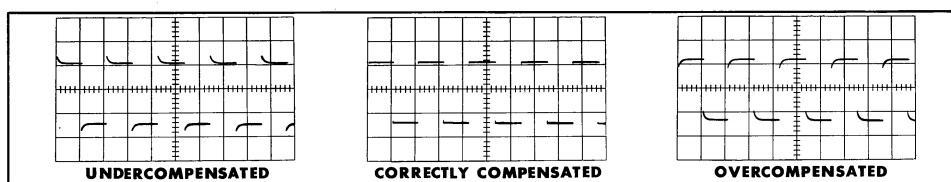

Fig. 2-1. The Type P6000 Probe Adjusting Sleeve is adjusted for a flat-topped square-wave display of the Calibrator waveform.

## Voltage Measurements

We describe these two categories of voltage measurements with the Type H Plug-In Unit: (1) measurement of the peak-to-peak voltage of a displayed waveform and (2) measurement of the peak voltage of a waveform with respect to a reference voltage. The specific examples that follow are intended to show the general procedure. These examples can be modified to suit any particular application.

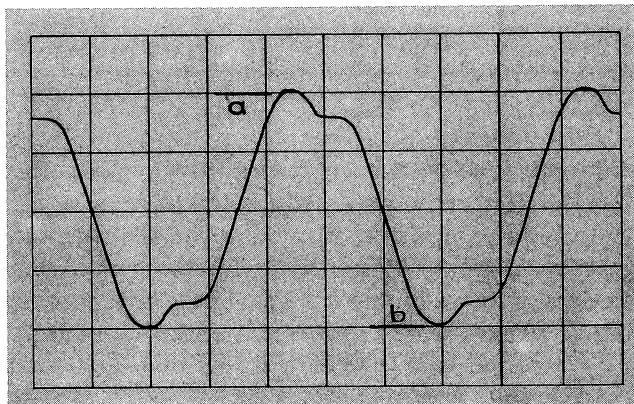

Fig. 2-2. Measuring peak-to-peak voltage. The text explains how the calibrated VOLTS/CM switch may be used to measure the peak-to-peak voltage of the typical waveform shown above.

How to measure the peak-to-peak voltage.

Suppose a given waveform produces the trace shown in Fig. 2-2 when a 10X probe is used and the plug-in controls are set as follows:

INPUT SELECTOR	AC
switch	
VOLTS/CM	.05
VARIABLE	CALIBRATED

The first step in measuring the peak-to-peak voltage of this waveform is to measure the amount of vertical deflection. The distance from point a, the positive peak, to point b, the negative peak, is 4 cm. Multiply this figure by the VOLTS/CM setting, .05, and



the result is .2 volts. This figure represents the voltage present at an INPUT connector of the plug-in unit. Multiply this result by 10--the attenuation ratio of the probe. This gives 2 volts as the peak-to-peak voltage of the displayed waveform.

### How to Measure a Peak Waveform Voltage with Respect to Ground

Set the INPUT SELECTOR switch to DC, and set the VARIABLE control to CALIBRATED. Adjust the oscilloscope for a free-running trace. Touch the probe tip to the oscilloscope ground terminal. Use the VERTICAL POSITION control to set the trace to a convenient position, such as b in Fig. 2-3. Next, disconnect the probe tip from the ground terminal and connect it to the waveform source without disturbing the VERTICAL POSITION control. Adjust the oscilloscope controls for a stable display. Observe the vertical distance between the peak waveform voltage a and the original trace position b. If this distance is inconveniently large or small, reset the VOLTS/CM switch to a more suitable position and repeat the above procedure.

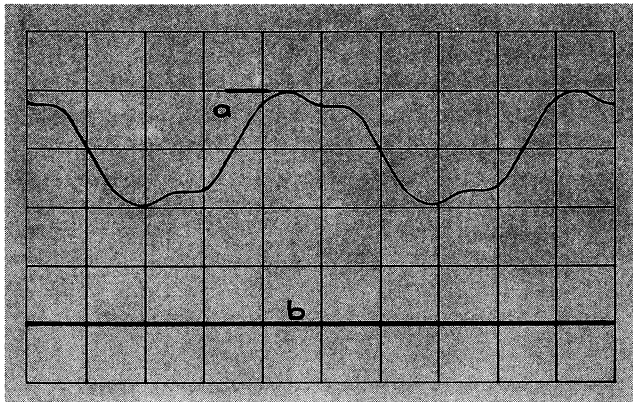

Fig. 2-3. Measuring a voltage with respect to ground. The text explains how the voltage difference between point "b" (ground) and point "a" may be measured with the aid of the calibrated VOLTS/CM switch.

As an example, suppose the vertical distance between a and b is 4 cm when a 10X probe is used and when the VOLTS/CM switch is set at .1. Multiply the distance between a and b (4 cm) by the VOLTS/CM setting (.1 v/cm) and by the probe attenuation ratio (10). This shows the peak voltage of the waveform with respect to ground to be 4 volts.

### Gain Adjustment

The gain adjustment should be checked periodically because aging of the tubes will affect the gain of the plug-in unit. This is done by setting the controls as follows:

VOLTS/CM	.005
VARIABLE	CALIBRATED
INPUT SELECTOR	INPUT A AC
AMPLITUDE CALIBRATOR	20 MILLIVOLTS

Connect a lead from the output connector of the oscilloscope square-wave calibrator to the Type H INPUT A connector. Set the oscilloscope controls for a stable display of the calibrator waveform. Adjust the GAIN ADJ. control so that the vertical deflection is four major graticule divisions.

### DC Balance Adjustment

The need for adjustment of the DC BAL. controls is indicated by a vertical shift in the position of the trace as the VARIABLE control is rotated.

This adjustment should be made as follows:

1. Adjust the GAIN ADJ. control as described previously.
2. Connect a lead from the INPUT A connector to ground, and set the INPUT SELECTOR switch to INPUT A AC. Adjust the oscilloscope controls for a free-running trace.
3. Slowly rotate the VARIABLE control back and forth, and adjust the COARSE DC BAL. control for the least amount of vertical shift.

It may be necessary to adjust the VERTICAL POSITION control at the same time to keep the trace in view.

4. Continue rotating the variable control slowly, and adjust the FINE DC BAL. control until the trace position is no longer affected by the rotation.



## CIRCUIT DESCRIPTION

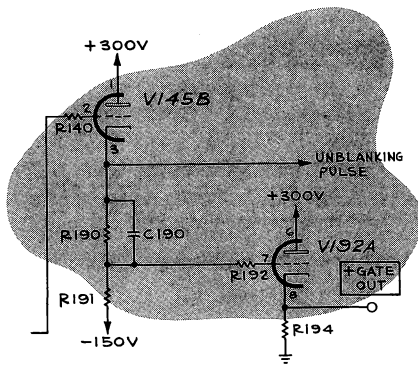

The Type H Plug-In Unit is a wide-band, fast-rise preamplifier with dc-coupling over its full sensitivity range. It provides a maximum deflection factor of 5 mv/cm, dc-coupled, with excellent transient response, and may be used with any Tektronix 530-, 540-, or 550-Series oscilloscope. It consists of two stages of push-pull amplification, each followed by a cathode-follower.

### Input Circuit

The Type H Preamplifier Plug-In Unit requires an input-signal voltage of .005 volts, peak-to-peak, to produce one centimeter of calibrated deflection on the crt of the oscilloscope. To satisfy this condition, yet make the unit applicable to larger input voltages, a precision attenuation network is employed ahead of the amplifier circuits.

When the VOLTS/CM SWITCH is in the .005 position, the signal is coupled "straight through" (that is, without attenuation) to the grid of V3854, one-half of the Input Amplifier stage. For settings of the VOLTS/CM switch between .01 and 20, the Attenuators are switched into the circuit so that the input signal voltage to the Input Amplifier is always .005 v for each centimeter of crt deflection when the VARIABLE knob is in the CALIBRATED position.

The Attenuators are frequency-compensated voltage dividers. For dc and low-frequency signals they are resistance dividers, and the degree of attenuation is determined by the resistance values. The impedance of the capacitors, at dc and low frequencies, is so high that their effect in the circuit is negligible. As the frequency of the input signals increases, however, the impedance of the capacitors decreases and their effect in the circuit becomes pronounced. For high-frequency signals the impedance of the capacitors is so low, compared

to the resistance of the circuit, that the Attenuators become capacitance dividers.

In addition to providing the proper degree of attenuation, the resistance values of the Attenuators are chosen so as to provide the same input resistance (1 megohm) regardless of the setting of the VOLTS/CM switch. Moreover, the variable capacitor, at the input to each Attenuator, provides a means of adjusting the input capacitance so that it is also the same value (47 picofarads) for all settings of the switch.

Two INPUT connectors, with more than 60-db isolation between them, are provided on the Type H Plug-In Unit. By means of the INPUT SELECTOR switch, either connector (INPUT A or INPUT B) can be switched into the circuit. In addition either INPUT connector can be ac- or dc-coupled to the Attenuator circuits, depending on the setting of the INPUT SELECTOR switch. In the AC positions of the switch, the signal is coupled through capacitors. In the DC positions the coupling capacitor is bypassed with a direct connection.

### Input Amplifier

The Input Amplifier (V3854-V4854) is a cathode-coupled phase inverter stage. That is, it converts a single-ended input signal to a push-pull output signal. The input signal is applied to the grid of V3854. R3846 is the input grid resistor. (This resistor becomes a part of each attenuation network when the VOLTS/CM switch is turned away from the .005 position). R3850, bypassed by C3850, prevents the grid from drawing excessive current (in the event the stage is overdriven) when DC input-coupling is used. R3851 is a suppressor for parasitic oscillations.

The time constant network R3855, R3856 and C3855, located in the cathode circuit of

V3854, compensates for the tendency of cascaded amplifiers to produce a rolloff at the leading corner of fast-rise pulses. R3856 provides compensation for optimum results.

V4854 operates as a grounded-grid amplifier; its input signal is developed across the cathode resistors R3857-R3858. The signal produced at the plate of V4854 is equal in amplitude, but opposite in polarity, to the signal developed at the plate of V3854. Hence, a push-pull output signal is produced in the plate circuit of the Input Amplifier Stage.

In addition to furnishing one-half of the push-pull output signal from the Input Amplifier stage, V4854 also couples a manually adjustable dc voltage from the DC BAL controls to the grid of V3863B. The function of this dc voltage will be explained a bit later.

The peaking coils in both plate circuits of the Input Amplifier compensate the stage for the high-frequency attenuation produced by the tube and stray capacitance in the circuit. The variable inductors (L3853-L4853) provide a means for adjusting the stage for optimum transient response.

The first C.F. stage, V3863, serves two important functions: The grid circuits present a high-impedance, low-capacitance load to the Input Amplifier; the cathode circuits provide the necessary low-impedance to drive the input capacitance of the Output Amplifier. The inter-stage peaking coils, L3871 and L4871, provide peaking for the leading edge of fast vertical signals.

## Output Amplifier

The Output Amplifier stage (V3874-V4874) contains two gain adjustments. The VARIABLE control R3878 (front-panel adjustment) regulates the gain over a 2 1/2 to 1 range by varying the degeneration in the cathode circuit. The GAIN ADJ. R3880 (screw-driver adjustment) varies the current flowing through the tubes. This varies the transconductance of the tubes and thus regulates the gain. The GAIN ADJ. control is adjusted so that the amount of crt deflection agrees with the setting of the VOLTS/CM switch, when the VARIABLE knob is turned full right (CW) to the CALIBRATED position.

In order that there will be no vertical shift of the crt beam as the VARIABLE control is adjusted, the voltages at the cathodes of the Output Amplifier must remain equal and constant. When the VARIABLE control is turned full right to the CALIBRATED position there is zero resistance between the two cathodes, and the cathode voltages will of course be equal. As the control is turned away from the CALIBRATED position, however, the resistance between the two cathodes will increase. If no provisions were made to insure that the cathode voltages remain constant, the added resistance could produce a difference in potential between the two cathodes which would result in a vertical shift of the crt beam. By means of the DC BAL. controls, however, the voltage at the cathode of V4874 can be adjusted to equal the voltage at the cathode of V3874, when the VARIABLE control is adjusted for maximum resistance. The DC BAL. controls comprised of R4832 and R4831 (COARSE), R4834 and R4835 (FINE), together with R4841 and R4842, form a divider to set the voltage at the grid of V4854. This dc voltage is coupled through the cathode follower V3863B to the grid, and then to the cathode of V4874. When these controls are properly adjusted, the cathodes of the Output Amplifier will remain at the same potential as the VARIABLE control is rotated, and no vertical shift of the crt beam will result.

(Note: The DC BAL. controls are actually used to balance the entire vertical deflection system in the oscilloscope. Their precise function is to insure that the dc potential between the vertical deflection plates does not vary as the VARIABLE control is rotated through its range. However, if the main Vertical Amplifier in the oscilloscope, and the Output C.F. in the plug-in unit are in the proper state of balance, the DC BAL. controls may be adjusted so that the potentials at the cathodes of the Output Amplifier remain equal and constant as the VARIABLE control is rotated.)

Additional high-frequency compensation occurs in the plate circuits of the Output Amplifier. A fixed amount of compensation is provided by L3873 and L3891 in one plate circuit, and by L4873 and L4891 in the other. The variable inductors L3874 and L4874, and the variable capacitors C3873 and C4873, provide a means for adjusting the compensation for optimum results.

Vertical positioning of the crt beam is accomplished through the action of the VERTICAL POSITION control R3885 (front-panel adjustment) and the VERT. POS. RANGE control R3886 (screwdriver adjustment). These control circuits are identical, so a description of one will be applicable to the other. The VERT. POS. RANGE control is a dual control, connected between +225 v and ground. It is connected electrically so that as the voltage between ground and the movable arm in one increases, the voltage between ground and the movable arm in the other decreases. The voltage at each arm of the control can vary a maximum of 225 volts, as the control is adjusted. This 225-volt variation is attenuated by a factor of 330 to 1.6 (the ratio of R3887 to R3874 on one side, and the ratio of R4887 to R4874 on the other) so that the maximum variation in voltage at the grids of V3893 is about 1 volt. This change in grid voltage at the Output C.F. stage will be reflected as a change in vertical deflection-plate voltage at the crt, since direct coupling is used between these two points. The VERT. POS. RANGE control is adjusted to center the crt beam vertically when the VERTICAL POSITION control is set to midscale.

The Output C.F. stage operates much the same as the First C.F. stage. That is, it provides a high-impedance, low-capacitance load to the Output Amplifier, and provides the necessary low impedance to drive the capacitance of the Interconnecting Plug and the input capacitance of the main Vertical Amplifier in the oscilloscope.

There is additional "leading edge" peaking in this stage. Peaking coils L3896 and L4896 form a series-resonant circuit, in their respec-

tive circuits, with the stray capacitance. These series circuits are damped by the cathode impedance of each side of V3893. Due to the fairly large cathode resistors employed (9.1K), the cathode impedance is approximately equal to the reciprocal of the transconductance of the tube (1/Gm). By varying the current through the tube, the H.F. PEAKING control (R3897) can vary the transconductance, thereby varying the effect of the peaking circuits. Cross-coupling capacitors C3894 and C4894 also contribute to the high-frequency response of the stage. These capacitors tend to provide a 180-degree phase differential between the signals developed in the cathode circuit, even though the grid signals may not be 180 degrees out of phase.

### Heater Circuit

The heaters in the Type H Plug-In Unit are supplied with direct current from the +100-volt regulated supply. This prevents the possibility of 60-cycle cathode modulation, which might result if the heaters were supplied with alternating current.

Power for the heater circuit (+75 v at 150 ma) is obtained from pin 15 of the Interconnecting Plug. The manner in which this power is obtained from the +100-volt regulator is shown in Fig. 3-1. For those instruments employing Delaying Sweep, the heaters of two of the tubes in the Delaying Sweep Generator are connected in series with the heater circuit of the Plug-In unit to provide the necessary 25-volt drop. In those instruments employing only one Sweep Generator, a resistor connected between the heater string and the +100-volt bus provides the necessary drop.

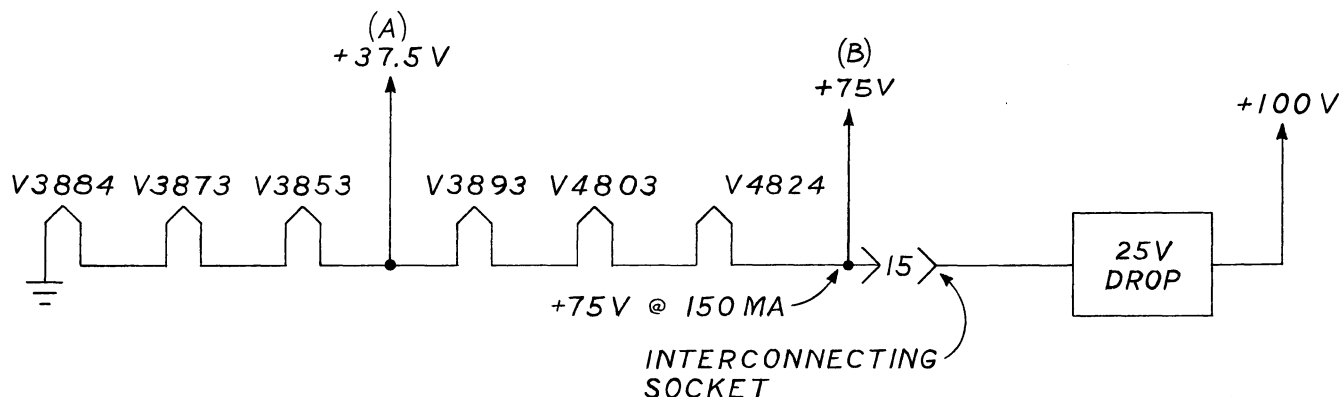
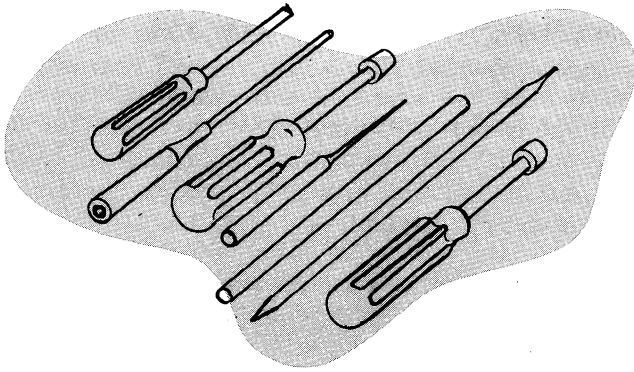

Fig. 3-1. Heater Circuit.



The heater circuit also provides a constant voltage source for the amplifier tubes; point (A) provides +37.5 volts for the plate circuit of the Input Amplifier, and point (B) provides +75 volts for the plate circuit of the Output

Amplifier. The heater circuit does not supply any current for the amplifier tubes; it simply acts as a low-impedance divider to "fix" the voltage at points (A) and (B).



### Note

Always include the instrument TYPE and SERIAL NUMBER in any correspondence concerning the instrument.

## Replacement Parts

### Standard Parts

Replacement parts for the Type H Plug-In Unit can be obtained from Tektronix at current net prices. However, since most of the components are standard electronic or radio parts, they can usually be obtained locally in less time than required to obtain them from the factory. There are a few exceptions to this, and these are noted in the Parts List. Before ordering or purchasing parts, be sure to consult the Parts List to determine the tolerances required.

### Aged and Selected Tubes

To obtain maximum reliability and performance, we check some of the tubes used in our instruments for such characteristics as  $G_m$ , microphonics, balance, etc. We age other tubes to stabilize their characteristics. The checked tubes are labeled and identified with a part number beginning with 157 \_\_\_\_. The 12AU6 tubes in the Input Amplifier stage are aged and checked for  $G_m$  and grid current. These tubes are assigned the part number 157-050. The 12AU6 tubes in the Output Amplifier are aged and checked for  $G_m$ ; they are assigned the part number 157-038. We suggest that you obtain these checked tubes, for replacement purposes, from the factory or from your local Tektronix field office.

Raw-stock...that is, unchecked tubes...are unlabeled tubes assigned the part number 154 \_\_\_\_. The 12AT7 tubes in the cathode follower stages are raw-stock tubes. However, since the Type

# MAINTENANCE

H Unit is a fast-rise preamplifier, tubes that develop a cathode-interface layer can be a source of trouble. To be assured of optimum transient response, be sure that any 12AT7 tubes used as replacements are good quality tubes.

### Tektronix-Manufactured Parts

Tektronix manufactures almost all of the mechanical parts, and some of the electronic components used in this instrument. When ordering mechanical parts be sure to describe the part fully to prevent delay in filling your order. Your local Tektronix Field Engineer will be pleased to assist you.

The Tektronix-manufactured electronic components are identified in the Parts List. These components, as well as the mechanical parts, must be obtained from the factory or from your Local Tektronix field office.

Since the production of your instrument, some of the Tektronix-manufactured components or parts may have been superseded by a newer, improved component or part. The part number of these newer components will not be listed in the Parts List. If you order a Tektronix-manufactured component, and if it has been superseded by a newer, improved component, the new component will be shipped in place of the original one. Your local Tektronix field office has knowledge of these changes and may call you if a change in your purchase order is necessary.

Where necessary, replacement-information notes accompany the improved component to aid in its installation.

### Soldering and Ceramic Strips

Many of the components in your Tektronix instrument are mounted on ceramic terminal

strips. The notches in these strips are lined with a silver alloy. Repeated use of excessive heat, or use of ordinary tin-lead solder will break down the silver-to-ceramic bond. Occasional use of tin-lead solder will not break the bond if excessive heat is not applied.

If you are responsible for the maintenance of a large number of Tektronix instruments, or if you contemplate frequent parts changes, we recommend that you keep on hand a stock of solder containing about 3% silver. This type of solder is used frequently in printed circuitry and should be readily available from radio-supply houses. If you prefer, you can order the solder directly from Tektronix in one-pound rolls. Order by Tektronix part number 251-514.

Because of the shape of the terminals on the ceramic strips it is advisable to use a wedge-shaped tip on your soldering iron when you are installing or removing parts from the strips. Fig. 4-1 will show you the correct shape for the tip of the soldering iron. Be sure and file smooth all surfaces of the iron which will be tinned. This prevents solder from building up on rough spots where it will quickly oxidize.

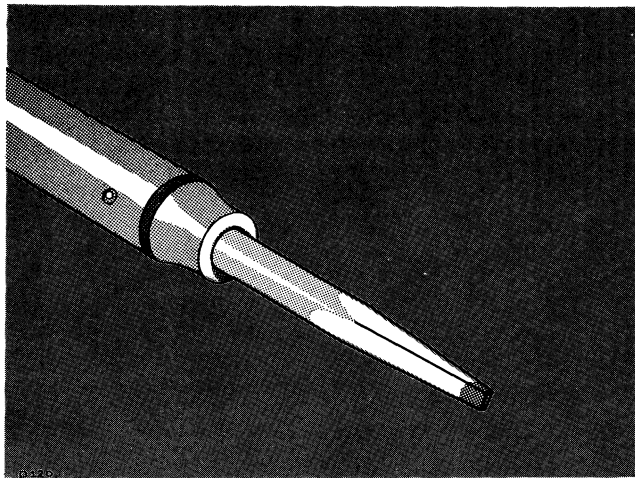

Fig. 4-1. Soldering iron tip properly shaped and tinned.

When removing or replacing components mounted on the ceramic strips you will find that satisfactory results are obtained if you proceed in the manner outlined below.

1. Use a soldering iron of about 75-watt rating.

2. Prepare the tip of the iron as shown in Fig. 4-1.
3. Tin only the first 1/16 to 1/8 inch of the tip. For soldering to ceramic terminal strips tin the iron with solder containing about 3% silver.
4. Apply one corner of the tip to the notch where you wish to solder (see Fig. 4-2).

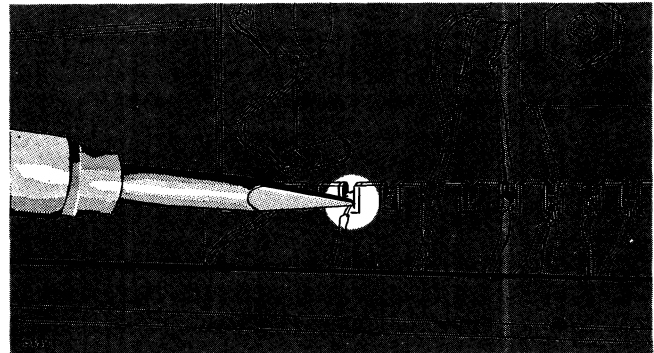

Fig. 4-2. Correct method of applying heat in soldering to a ceramic strip.

5. Apply only enough heat to make the solder flow freely.
6. Do not attempt to fill the notch on the strip with solder; instead, apply only enough solder to cover the wires adequately, and to form a slight fillet on the wire as shown in Fig. 4-3.

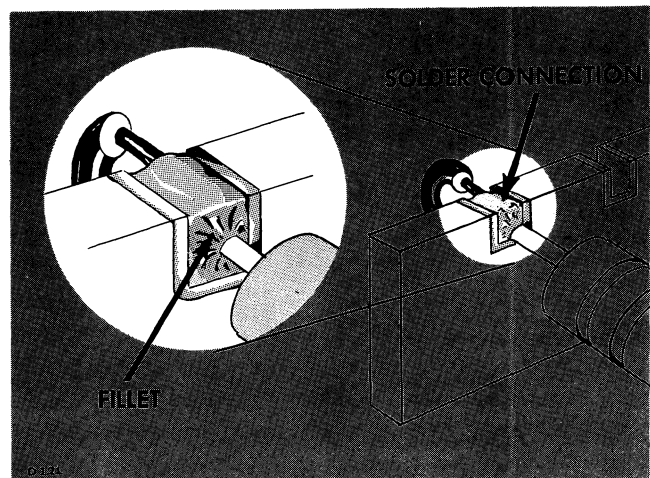

Fig. 4-3. A slight fillet of solder is formed around the wire when heat is applied correctly.

In soldering to metal terminals (for example, pins on a tube socket) a slightly different

technique should be employed. Prepare the iron as outlined above, but tin with ordinary tin-lead solder. Apply the iron to the part to be soldered as shown in Fig. 4-4. Use only enough heat to allow the solder to flow freely along the wire so that a slight fillet will be formed as shown in Fig. 4-3.

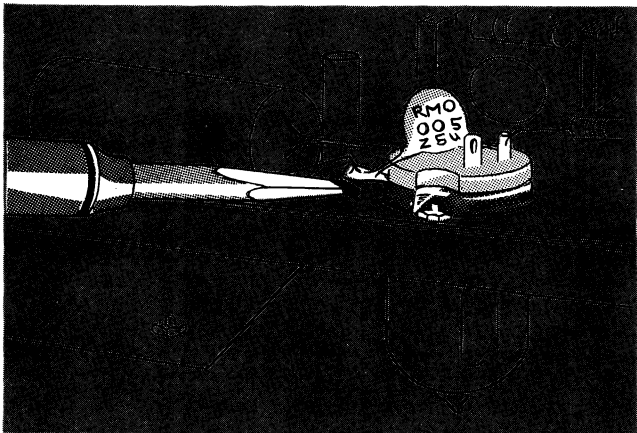

Fig. 4-4. Soldering to a terminal. Note the slight fillet of solder--exaggerated for clarity--formed around the wire.

## General Soldering Considerations

When replacing wires in terminal slots clip the ends neatly as close to the solder joint as possible. In clipping ends of wires take care the end removed does not fly across the room as it is clipped.

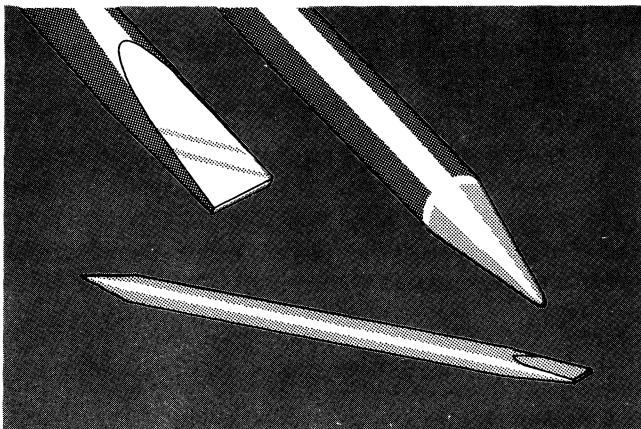

Fig. 4-5. A soldering aid constructed from a 1/4 inch wooden dowel.

Occasionally you will wish to hold a bare wire in place as it is being soldered. A handy device for this purpose is a short length of wooden dowel, with one end shaped as

shown in Fig. 4-5. In soldering to terminal pins mounted in plastic rods it is necessary to use some form of "heat sink" to avoid melting the plastic. A pair of long-nosed pliers (see Fig. 4-6) makes a convenient tool for this purpose.

## Ceramic Strips

Two distinct types of ceramic strips have been used in Tektronix instruments. The earlier type mounted on the chassis by means of #2-56 bolts and nuts. The later type is mounted with snap-in, plastic fittings. Both styles are shown in Fig. 4-7.

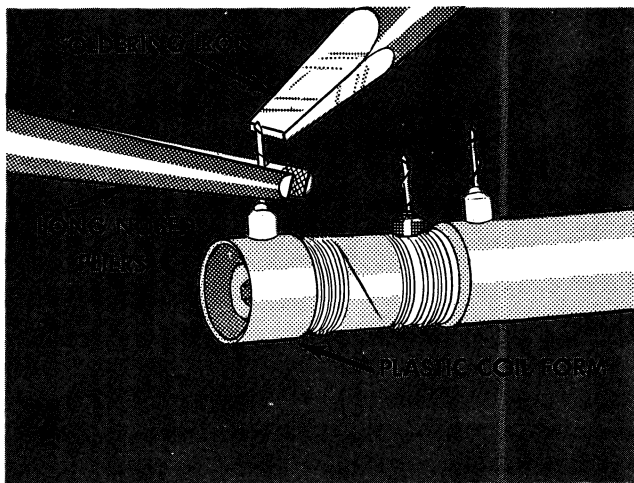

Fig. 4-6. Soldering to a terminal mounted in plastic. Note the use of the long-nosed pliers between the iron and the coil form to absorb the heat.

To replace ceramic strips which bolt to the chassis, screw a #2-56 nut onto each mounting bolt, positioning the bolt so that the distance between the bottom of the bolt and the bottom of the ceramic strip equals the height at which you wish to mount the strip above the chassis. Secure the nuts to the bolts with a drop of red glyptal. Insert the bolts through the holes in the chassis where the original strip was mounted, placing a #2 star-washer between each nut and the chassis. Place a second set of #2 flatwashers on the protruding ends of the bolts, and fasten them firmly with another set #2-56 nuts. Place a drop of red glyptal over each of the second set of nuts after fastening.

## Mounting Later Ceramic Strips

To replace strips which mount with snap-in plastic fittings, first remove the original fittings

from the chassis. Assemble the mounting post on the ceramic strip. Insert the nylon collar into the mounting holes in the chassis. Carefully force the mounting post into the nylon collars. Snip off the portion of the mounting post which protrudes below the nylon collar on the reverse side of the chassis.

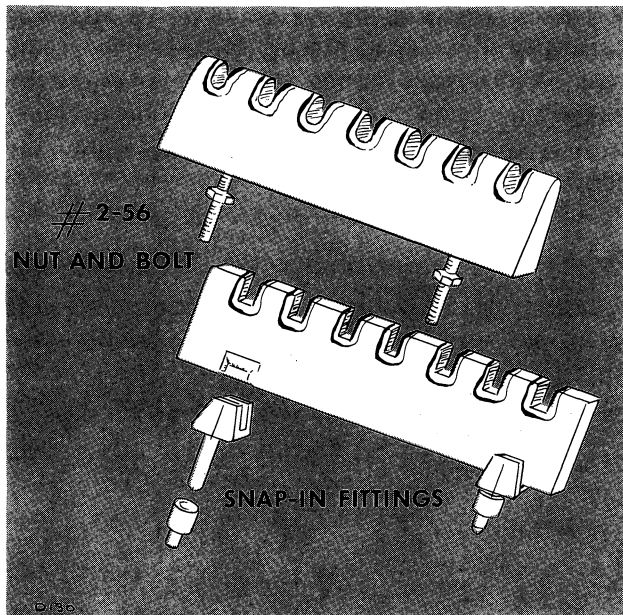

Fig. 4-7. Two types of ceramic strip mountings.

### Note

Considerable force may be necessary to push the mounting rods into the nylon collars. Be sure that you apply this force to that area of the ceramic strip directly above the mounting rods.

## Troubleshooting Information

### General Information

Any defect that may be apparent in the crt display of an oscilloscope, or the absence of a display, may be due to a malfunction in either the plug-in unit or the oscilloscope itself. The faulty unit can readily be determined by inserting another plug-in unit, known to be in operating condition, into the oscilloscope and checking the results. If the trouble is still apparent, it can be assumed that the original plug-in unit is not at fault and that the trouble lies somewhere within the oscillo-

scope. However, should the trouble appear to have been corrected, it is almost a certainty that the defect lies within the plug-in unit itself.

Tube failure is the most prevalent cause of circuit failure. For this reason, the first step in troubleshooting any circuit is to check for defective tubes, preferably by direct substitution. Do not depend on tube testers to adequately indicate the suitability of a tube for certain positions in the instrument. The criterion for usability of a tube is whether or not it performs satisfactorily in the instrument. Be sure to return any tubes found to be good to their original socket. If this procedure is followed, less recalibration of the instrument will be required upon completion of the servicing. (See "Aged and Selected Tubes," Page 4-1.)

If replacement of a defective tube does not correct the trouble, then check that the components through which the tube draws current have not been damaged. Shorted tubes will often overload and damage plate load and cathode resistors. These components can sometimes be detected by a visual examination of the circuit. If no damaged components are apparent, however, it will be necessary to make measurements or other checks within the circuit to locate the trouble.

The first step in troubleshooting a Type H Plug-In Unit, after determining that tubes are not at fault, is to determine the stage in which the trouble is being produced. The procedure for this will be explained in the section on trouble analysis that follows. Once the trouble has been isolated to a particular stage, the component(s) causing the trouble can be found by voltage and resistance measurements, continuity checks, or component substitution.

### Trouble Analysis and Circuit Isolation

Troubles that can be caused by a malfunctioning or improperly adjusted Type H Unit are:

1. Loss of trace.
2. Inability to position the trace.
3. No waveform display (horizontal trace present).
4. Insufficient vertical gain.



## 5. Waveform distortion.

This section contains information for isolating the source of each type of trouble to a particular stage, and in some instances to a particular component. The Circuit Description may prove useful when troubleshooting within a particular stage.

It will be necessary to remove the left side cover and the bottom plate from the oscilloscope to troubleshoot the plug-in unit.

### 1. Loss of Trace

For the beam to be visible on the crt, the dc output voltages (at pins 1 and 3 of the interconnecting plug) must be essentially equal...that is, within a fraction of a volt. As little as a 0.2-volt difference between these two points may position the beam above or below the range of visibility.

The dc output voltages depend on the dc balance of the amplifier. Since the amplifier is dc-coupled from input to output, a condition anywhere between these two points that will unbalance the output voltages more than 0.2 volt may cause a loss of the trace. A possible cause of this condition would be an improper adjustment of either or both of the DC BAL. controls. To check the settings of these controls, proceed as follows:

- a. Adjust the oscilloscope Time Base controls for a free-running sweep.
- b. Set the FINE DC BAL. control to the center of its range.
- c. Adjust the COARSE DC BAL. control slowly, observing the crt to see if the trace appears. If the trace appears during this check, adjust the controls in accordance with the instructions in the Operating Instructions section of the manual.

Another cause of this trouble could be an improper adjustment of the VERT. POS. RANGE control R3886. The setting of this control can be checked as follows:

- a. Adjust the oscilloscope Time Base Controls for a free-running sweep.
- b. Set the VERTICAL POSITION control to the center of its range.

- c. Adjust the VERT. POS. RANGE control slowly, observing the crt to see if the trace appears. If the trace appears during this check, adjust the control in accordance with the instructions in the Recalibration Procedure.

If the loss of the trace is not due to an improper control adjustment, the unbalance is being produced by defective tubes, defective cathode, screen and plate resistors, shorted or leaky capacitors, open peaking coils, or improper resistance ratios in the voltage dividers. A step by step isolation procedure can then be used to determine the stage in which the unbalance is being produced. This procedure is accomplished by shorting together corresponding points on opposite sides of the amplifier, starting at the output and working back toward the Input Amplifier stage. For example, when pins 1 and 3 of the interconnecting plug are shorted together (with the Time-Base controls adjusted for a free-running trace), the voltages at these points will be equal and the trace will appear at or near the center of the crt. From this point, the shorting strap can be moved back, in successive steps, to

- a. The cathodes (pins 3 and 8) of V3893.
- b. The grids (pins 2 and 7) of V3893.
- c. The plates (pin 5) of V3874 and V4874.
- d. The grids (pin 1) of V3874 and V4874.
- e. The cathodes (pins 3 and 8) of V3863.
- f. The grids (pins 2 and 7) of V3863.

Following this procedure a point will be reached where the trace cannot be made to appear when corresponding sides of the amplifier are shorted together. When this occurs, the defect has been isolated to the stage in which these points are located. For example, if the trace appears when the grids of the Output C.F. are shorted together, but does not appear when the plates of the Output Amplifier stage are shorted together, an open peaking coil L3874, L3891, L4874 or L4891 is indicated.

Whenever any points between the grids of the Output Amplifier and the grids of the First C.F. are shorted together, the effect of the vertical positioning controls must be considered. It will be necessary to check

the adjustment of both the VERTICAL POSITION control and the VERT. POS. RANGE control when any points between these two stages are shorted together.

There is a possibility that the loss of trace may be due to a defective heater circuit. This condition can be determined by observing the tubes in the plug-in unit for heater glow. If no glow is observed, it will most likely be due to an open heater in one of the tubes. Other possibilities are shorted capacitors C4820, C4821 and C4825.

## 2. Inability to position the trace

If a trace is visible on the crt, but it cannot be moved with the VERTICAL POSITION control, some defect that is rendering this control inoperative is indicated. If the trace can be moved with the VERT. POS. RANGE control, the VERTICAL POSITION control itself is probably defective. If the trace cannot be moved with the VERT. POS. RANGE control, however, the trouble will lie in some circuit following the Output Amplifier stage. The trouble could be an open H.F. PEAKING control R3897. It could also be a short between correspondingly-opposite sides of the amplifier; an examination of the lead dress, or a continuity check with an ohmmeter, would reveal this condition.

## 3. No waveform display (horizontal trace present)

If a horizontal trace is present on the crt, but you are unable to obtain a waveform display, an open circuit somewhere in the amplifier is indicated. However, since a horizontal trace is present, the defective component is one that does not affect the dc balance of the amplifier.

If the trace can be moved over its normal range with the VERTICAL POSITION control, the trouble is occurring somewhere ahead of the plate circuit of the Output Amplifier stage. The trouble could be an open cathode resistor or an open screen divider in either the Input Amplifier or the Output Amplifier. If the trace cannot be moved with the VERTICAL POSITION control, the trouble will be originating in the output stage. This could be an open H.F. PEAKING control R3897.

## 4. Insufficient vertical gain

If the vertical deflection on the crt no longer

corresponds to the calibrated value, a change in the gain characteristics of the plug-in is indicated. If only a small change in the gain has occurred, the unit can generally be recalibrated to restore the gain to its calibrated value. If the change in gain is more pronounced, however, a change of tubes or circuit components is indicated.

If tubes are causing the trouble, it will most likely be the 12AU6 tubes in either the Input Amplifier or the Output Amplifier stage. It is unlikely that the cathode-follower tubes will affect the gain to any large degree.

An open VARIABLE control will greatly decrease the gain of the Output Amplifier stage. The gain can also be decreased by an increase in the value of the cathode resistors, or by a change in the values of the screen dividers.

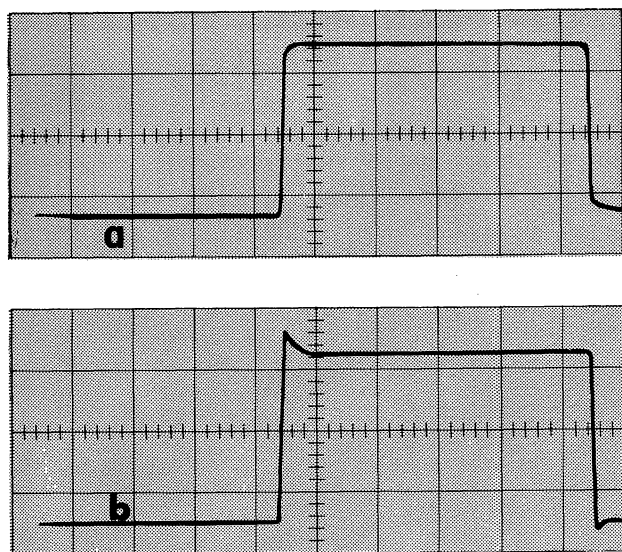

Fig. 4-8. Two types of high-frequency distortion: (a) rolloff, and (b) overshoot.

## 5. Waveform distortion

Any waveform distortion that may be produced by a Type H Unit will be of a high-frequency nature. There will be no low-frequency distortion, since the amplifier is dc-coupled from input to output (unless one or more of the tubes enter into heavy current, a condition that will produce other types of distortion as well).

High-frequency distortion will generally be manifest in either a rolloff or an overshoot

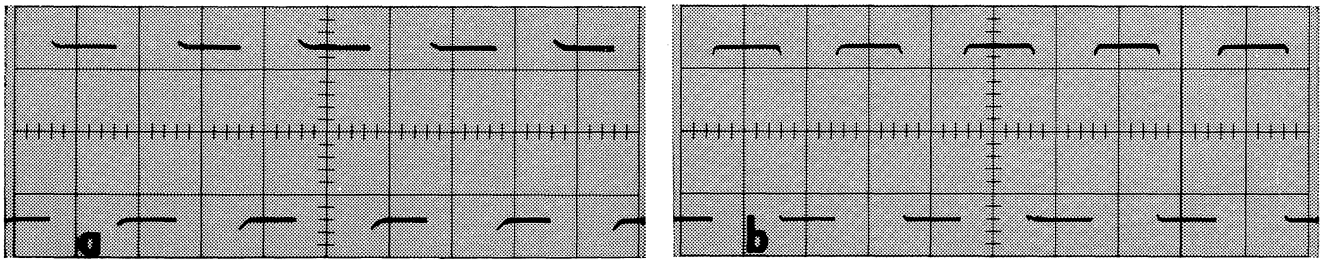

Fig. 4-9. Interface distortion: (a) 100-kc square wave at 5  $\mu$ sec/cm; (b) 500-kc square wave at 1  $\mu$ sec/cm.

at the leading corner of a fast-rise stepfunction. Fig. 4-8 (a) shows an example of rolloff. The tubes should first be checked for this type of distortion. If a tube cannot deliver current instantaneously, on demand, the high-frequency response of the amplifier will deteriorate. An improper adjustment of any of the peaking coils can produce a rolloff. A misadjusted H.F. PEAKING control can also produce a slight rolloff, but this will only be visible at the faster sweep rates. Shorted or partially shorted peaking coils are often a source of high-frequency rolloff; this condition is generally produced by hot solder falling on the coils. Be especially careful when soldering around any of the peaking coils.

Cross-coupling capacitors C3894 and C4894 are very important in maintaining the proper risetime of fast-rise pulses. An open condition in either capacitor will seriously affect the high-frequency response.

Excessive high-frequency peaking, due to improper adjustment of the peaking controls, can produce the overshoot condition shown in Fig. 4-8 (b). Refer to the Recalibration Procedure for the proper method of adjusting these controls. However, an overshoot at the leading edge of a fast-rise pulse is often the result of cathode interface in the amplifier tubes. Since the time constant of the interface layer is normally in the range from .1 to 3  $\mu$ sec, the effect of interface is most noticeable on waveforms whose period is very long compared to the interface time constant. Fig. 4-9 (a) shows the effect of interface on a 100-kc fast-rise pulse, with the oscilloscope sweep rate set for 5  $\mu$ sec/cm. This same distortion is less noticeable on the 500-kc square wave, at a sweep rate of 1  $\mu$ sec/cm, shown in Fig. 4-9 (b). Since this type of distortion is produced by the tubes themselves, it is important that the tubes be checked when such distortion is evident.



# CALIBRATION PROCEDURE

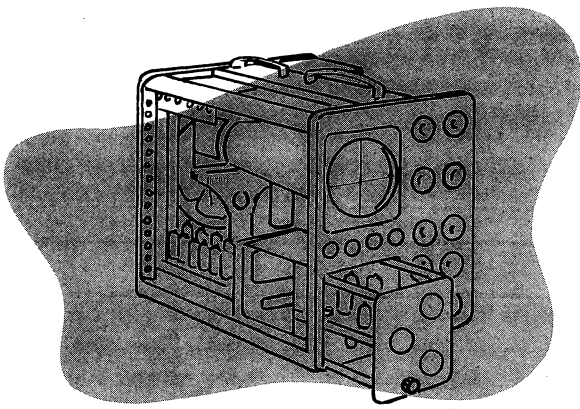

The Type H Unit is a stable preamplifier, and should not require frequent recalibration. However, it will be necessary to check the calibration when tubes and components are changed, and a periodic check of the calibration is desirable from the standpoint of preventive maintenance. Minor operational deficiencies that may not be apparent in normal usage can often be detected during a calibration check.

## Equipment Required

The following equipment, or its equivalent, is required to check the calibration of the Type H Unit.

1. Tektronix convertible Oscilloscope.
2. Tektronix Type 190, 190A, or 190B Constant-Amplitude Signal Generator

### Specifications:

- a. Sine-wave output, variable in frequency from 500 kc to at least 15 mc.
- b. Output amplitude of 15 mv, amplitude to remain constant over above frequency range.

3. Tektronix Type 105 Square-Wave Generator

### Specifications:

- a. Square-wave output, repetition rate of 1 kc and 450 kc.
- b. Output amplitude variable over the range from 17.5 mv to 17.5 v.
- c. Risetime not to exceed .02  $\mu$ sec.

4. 5:1 L Attenuator Pad (Tektronix Type B52-L5).

5. 10:1 L Attenuator Pad (Tektronix Type B52-L10).
6. 10:1 T Attenuator Pad (Tektronix Type B52-T10).
7. 52-ohm Terminating Resistor (Tektronix Type B52-R).
8. Input Capacitance Standardizer (Tektronix Type CS-47).
9. 52-ohm Coaxial Cable (Tektronix Type P52).
10. DC Volt-Ohmmeter.
11. Alignment tools (see Fig. 5-1).

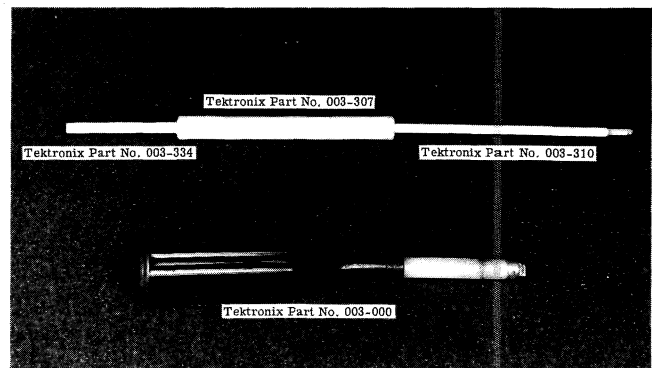

Fig. 5-1 Low capacitance, insulated alignment tools used to adjust the Type H Plug-in Unit. The upper tool is for capacitor, turret and coil adjustments, while the lower tool is for potentiometer adjustments.

## Checking the Calibration

### 1. Preliminary

Before installing the Type H Plug-In Unit in the oscilloscope, make a careful visual inspection of the wire dress. This is particularly important if any soldering has been done to the unit. Then make the following resistance-to-ground checks at the 16-pin interconnecting



plug. The table below lists the nominal resistance value from each pin to ground.

NOMINAL RESISTANCES AT INTERCONNECTING PLUG

PIN NUMBER	RESISTANCE-TO-GROUND
1	10 k $\Omega$
2	0
3	10 k $\Omega$
4	infinite
5	infinite
6	infinite
7	infinite
8	infinite
9	55 k $\Omega$
10	2 k $\Omega$
11	12 k $\Omega$
12	infinite
13	infinite
14	infinite
15	75 $\Omega$
16	infinite

Install the Type H Unit in the oscilloscope, turn on all equipment and allow 15 minutes for warmup. Unless otherwise stated, set up the oscilloscope controls as follows:

HORIZONTAL DISPLAY	INTERNAL SWEEP (Type 541) NORMAL (Type 543) MAIN SWEEP NORMAL (Type 545) " A" (Type 545A)
TRIGGERING MODE	AUTOMATIC
TRIGGERING SLOPE	-INT.
STABILITY TRIGGERING LEVEL	Not used in Automatic mode
TIME/CM	1 MILLISEC
VARIABLE	CALIBRATED
5X MAGNIFIER	OFF

Set the controls on the Type H Plug-In Unit as follows:

VOLTS/CM	.005
----------	------

VARIABLE CALIBRATED

INPUT SELECTOR INPUT A DC

VERTICAL POSITION Trace centered on crt

Remove the left-side cover from the oscilloscope; then lay the instrument on its right side and remove the bottom plate. It will be convenient to leave the instrument in this position (on its right side). If sufficient time has been allowed for warmup (about 15 minutes), you can now proceed to check the calibration of the plug-in unit.

## 2. DC Output Level

Measure the voltage between pin 1 and ground, and between 3 and ground, of the interconnecting plug. These voltages should measure +67 to 70 volts.

## 3. DC Balance

Adjust the FOCUS, INTENSITY and ASTIGMATISM controls for a well-defined trace of suitable intensity; adjust the SCALE ILLUM control for a pleasing level. Rotate the VARIABLE control on the plug-in unit back and forth over its range. If the trace remains stationary, as the VARIABLE control is rotated, no adjustment of the DC BAL. controls is necessary. If the trace shifts vertically, as the VARIABLE control is rotated, adjust the COARSE DC BAL. control until the trace remains almost stationary; final adjustment is made with the FINE DC BAL. control.

## 4. Vertical Position Range

- If the plug-in unit is to be used only with the oscilloscope in which it is being checked, the adjustment of the VERT. POS. RANGE control can be checked as follows: Set the VERTICAL POSITION control to mid-range. If the trace does not coincide with the center of the graticule, adjust the VERT. POS. RANGE control until coincidence is obtained.
- If the plug-in unit is to be used with oscilloscopes other than the one in which it is being checked, the adjustment of the VERT. POS. RANGE control should be made as follows: Set the VERTICAL POSITION control to mid-range. Short together pins 1 and 3 of the interconnecting plug and

observe the exact position of the trace; this is the electrical center of the vertical deflection system in the oscilloscope. Remove the short and adjust the VERT. POS. RANGE control so that the trace is positioned at the electrical center of the vertical deflection system. The final setting of the VERT. POS. RANGE control should be within the center one-half of its range.

### 5. Gassy and Microphonic Tubes

- a. Gas check: Center the trace vertically on the crt. Connect a jumper lead between a ground connector and the INPUT A connector on the plug-in unit, observing for any vertical shift in the trace as the input is grounded. It may be necessary to alternately remove and connect the jumper two or three times to determine the amount of shift, if any. The maximum permissible shift is 2.5 millimeters (1.25 minor divisions).
- b. Microphonics check: Rap lightly on the front panel of the plug-in unit and observe the trace for any excessive ringing-type microphonics.

### 6. Gain Adjustment

Set the front-panel controls of the plug-in unit as follows:

VOLTS/CM .005

VARIABLE CALIBRATED  
(full right)

INPUT SELECTOR INPUT A DC

Set the oscilloscope AMPLITUDE CALIBRATOR control as follows:

20 MILLIVOLTS

Connect a jumper from the CAL. OUT connector on the oscilloscope to the INPUT A connector on the plug-in unit. The vertical deflection on the crt should be exactly 4 centimeters. If not, adjust the GAIN ADJ. control until the vertical deflection is exactly 4 centimeters. Check the setting of the FOCUS and ASTIGMATISM controls to make sure this

adjustment is made with the narrowest trace width.

### 7. Input Selector Switch

With the controls unchanged from the previous step, position the base line of the calibrator waveform to the center line of the graticule. Set the INPUT SELECTOR switch to INPUT A AC; the waveform should shift down so that the center graticule line is now through the approximate center of the display. Remove the signal from INPUT A and apply it to INPUT B; check both positions of the INPUT SELECTOR switch for INPUT B.

### 8. Volts/Cm Switch

With the calibrator signal applied to INPUT B and the INPUT SELECTOR switch set to INPUT B DC, check the vertical deflection for the switch settings listed in the following table. Make sure the red VARIABLE control on the plug-in unit is in the CALIBRATED position.

Volts/Cm Switch Calibration Check

AMPLITUDE CALIBRATOR	VOLTS/CM SWITCH (black knob)	VERTICAL DEFLECTION
20 MILLIVOLTS	.005	4 cm
20 MILLIVOLTS	.01	2 cm
50 MILLIVOLTS	.02	2.5 cm
.2 VOLTS	.05	4 cm
.2 VOLTS	.1	2 cm
.5 VOLTS	.2	2.5 cm
2 VOLTS	.5	4 cm
2 VOLTS	1	2 cm
5 VOLTS	2	2.5 cm
20 VOLTS	5	4 cm
20 VOLTS	10	2 cm
50 VOLTS	20	2.5 cm

### 9. Input Capacitance and Attenuator Compensation

A 1-kc square wave from the Type 105 Square-Wave Generator is used to check the input capacitance and the Attenuator compensation of the Type H Unit. Turn the DC ON-OFF switch on the Type 105 to the OFF position (leave the AC ON-OFF switch in the ON position), and connect a 5:1 L Pad (B52-L5) to the OUTPUT connector of the Type 105. Connect a 52-ohm coaxial cable to the 5:1 L Pad, and connect the other end of the cable through a CS-47 Capacitance Standardizer to the INPUT A connector of the Type H Unit. Turn the DC ON-OFF switch on the Type

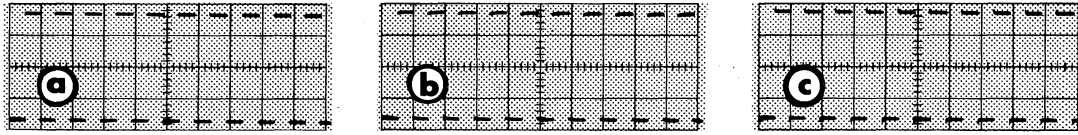

Fig. 5-2. Checking the input capacitance and the Attenuator compensation of the Type H Plug-In Unit: (a) proper adjustment; (b) improper adjustment of input capacitance; (c) Attenuator overcompensated.

105 to the ON position, and adjust the RANGE and FREQUENCY controls for an output frequency of 1 kc. Set the INPUT SELECTOR switch on the plug-in unit to INPUT A DC.

The following table lists settings of the VOLTS/CM switch that will connect each Attenuator into the input circuit individually. The table also lists the capacitor(s) that will affect the waveshape for each setting of the VOLTS/CM switch and the effect of each capacitor when the input circuit is properly adjusted, the waveform will have a square corner and a flat top for each position of the VOLTS/CM switch, as shown in Fig. 5-2 (a). The waveforms in (b) and (c) in Fig. 5-2 show two types of waveform distortion that may result from improperly adjusted capacitors.

HF-COMPENSATION ATTENUATOR ADJUSTMENTS

VOLTS/CM SWITCH	AFFECTS CORNER OF SQUARE WAVE	AFFECTS TOP OF SQUARE WAVE
.005		C3809
.01	C3834	C3833
.02	C3840	C3839
.05	C3812	C3811
*.5	C3818	C3817
5	C3824-C3828	C3823

\*Remove 5:1 L Pad from OUTPUT connector of Type 105.

Maintain approximately 3.5 centimeters of vertical deflection by adjusting the OUTPUT AMPLITUDE control of the Type 105 each time the VOLTS/CM switch is moved from one position to the next. In the last two positions of the switch (.5 and 5) it will be necessary to remove the 5:1 L Pad from the OUTPUT connector of the Type 105 and connect the cable directly to the OUTPUT connector. We suggest that you turn the DC ON-OFF switch to the OFF position while removing the 5:1 L Pad and reconnecting the cable directly to the Type 105.

### Input Capacitance and Turret Compensations (S/N 10,000 - up)

1. Set up the Type 105 Square-Wave Generator,

and cable with its pads and standardizer as explained above.

2. Set the Type H turret knob at the .005 VOLTS/CM position. Remove the outside part of the turret knob. Mark the inner part of the turret knob in such a manner as to have the mark pointing at the .005 VOLTS/CM marked on the front panel.
3. With the turret in the .005 VOLTS/CM position adjust C3846 (mounted on chassis) for a flat top on the square-wave presentation.
  - 3a. At serial number 10382 a capacitor (C3805) was added in parallel with C3806. The new capacitor is to provide for adequate adjustment of the attenuator compensations. This capacitor is normally adjusted for optimum results at the factory and should not need adjustment later.
4. Turn the turret to .01 VOLTS/CM and adjust the shunt capacitor for a flat top on the waveform, and the series capacitor for a square corner on the square-wave presentation. The adjustments of the capacitors in the other positions is done in the same manner as outlined above.

## 10. High Frequency Compensation

The high-frequency compensation of the Type H Unit is checked by observing the leading edge and corner of a 450-kc square wave from the Type 105. It is very important that the output of the Type 105 is properly terminated and attenuated for this operation.

Connect a B52-R Terminating Resistor to the INPUT A connector of the plug-in unit, and connect a B52-T10 T Pad to the other end of the Terminating Resistor. Connect a 52-ohm coaxial cable to the T Pad, and connect the other end of the cable to the Type 105 OUTPUT connector through a B52-L10 L Pad. (See Fig. 5-3). Set the RANGE and FREQUENCY controls of the Type 105 for an output frequency of 450 kc.

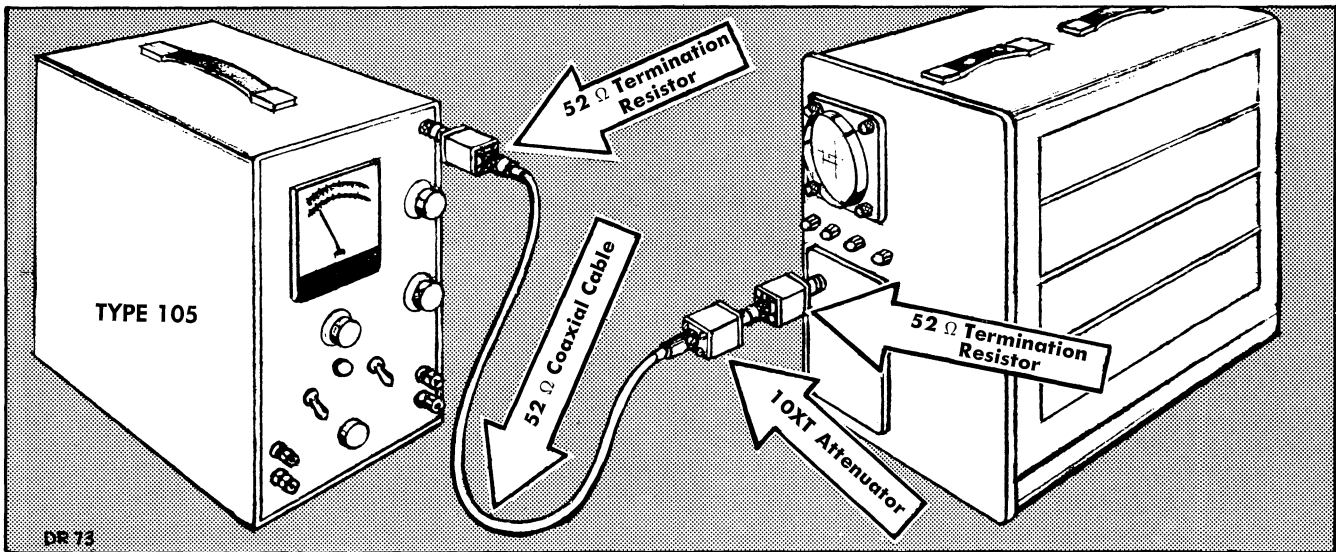

Fig. 5-3. The manner in which the Type 105 Square-Wave Generator should be connected to the Type H Plug-In Unit to check the high-frequency compensation.

Reset the following controls on the oscilloscope as indicated:

TIME/CM .2 MICROSEC

Set up the Type H Unit as follows:

VOLTS/CM .005  
 VARIABLE CALIBRATED  
 INPUT SELECTOR INPUT A DC

Adjust the OUTPUT AMPLITUDE control on the Type 105 for a vertical deflection of about 3 centimeters.

If the high-frequency compensating circuits in the Type H Unit are in proper adjustment, these control settings should result in a display of the Type 105 waveform similar to that shown in Fig. 5-4 (a). However, if there is any rolloff at the corner, as shown accentuated in Fig. 5-4 (b), or overshoot (with or without ringing) as shown in Fig. 5-4 (c), the high-frequency compensating circuits are in need of adjustment.

The following table lists each control that affects the high-frequency response of the plug-in unit, and the relative time constant of each control. Each of these controls will affect the leading corner of the square wave, however, the duration of the time constant will determine the degree to which the effect can be noticed. For example, the controls having a relatively short time constant will have their action confined more nearly to the vertex of the corner, while the longer time-constant controls

will affect a wider portion of the corner. The plug-in unit is adjusted for optimum high-frequency response when the corner is square and there are no aberrations in the top of the waveform immediately following the corner.

#### EFFECT OF HF ADJUSTMENT

CONTROL	RELATIVE TIME CONSTANT
R3856	Very long
C3873-C4873	Long
*L3874-L4874	Medium
**L3853-L4853	Short
R3897 (HF PEAKING)	Very short

\*When properly adjusted, the tuning slug should be on the top side of the center tap (the side farthest from the chassis).

\*\*When properly adjusted, the tuning slug should be on the bottom side of the center tap (the side nearest the chassis).

## 11. Frequency Response Measurement

The frequency response of the plug-in-oscilloscope combination is checked by applying a 500-kc sine wave from the Type 190 or Type 190A, 190B Constant-Amplitude Signal Generator to the Type H Unit, and adjusting the output amplitude from the signal generator for a reference amount of deflection on the crt. The frequency of the output signal is then increased, while maintaining the same output amplitude, until the deflection on the crt has decreased 3 db from the reference deflection; the frequency of the output signal then represents

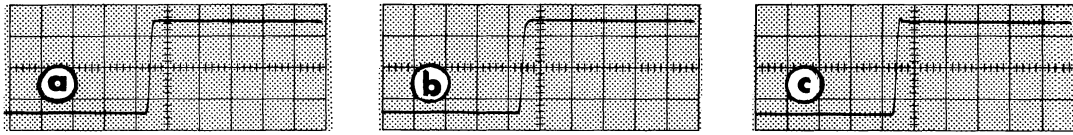

Fig. 5-4. Checking the high-frequency compensation of the Type H Plug-In Unit: (a) proper adjustment; (b) rolloff, and (c) overshoot, caused by improper adjustment.

the upper 3-db frequency of the plug-in-oscilloscope combination.

To make this check, set the plug-in controls as explained in Step 10 and reset the following controls on the oscilloscope:

TIME/CM	100 MICROSEC
TRIGGERING MODE	AC or AC SLOW
STABILITY	full right (cw)

Connect the ATTENUATOR box of the Type 190, 190A or 190B to the INPUT A connector of the plug-in unit through a 5:1 L Pad (B52-L5), and adjust the controls on the signal generator as follows:

RANGE SELECTOR .35-.75

RANGE IN .50 (on the .35-.75 scale)  
MEGACYCLES

Set the switch on the ATTENUATOR box to 1, and adjust the OUTPUT AMPLITUDE control of the signal generator for a vertical deflection of exactly 3 centimeters (make sure the VOLTS/CM and VARIABLE controls on the plug-in unit are set to .005 and CALIBRATED, respectively). Then, set the RANGE SELECTOR switch on the signal generator to 9-21, and adjust the RANGE IN MEGACYCLES control until the vertical deflection on the crt is exactly 2.1 centimeters. The VERTICAL POSITION control on the plug-in unit may be adjusted to make the measurements more convenient, but do not adjust any other controls on either the plug-in unit or the signal generator (with the exception of the RANGE IN MEGACYCLES control). A vertical deflection of exactly 2.1 centimeters represents the upper 3-db frequency of the circuit; this should be at least 15 megacycles.

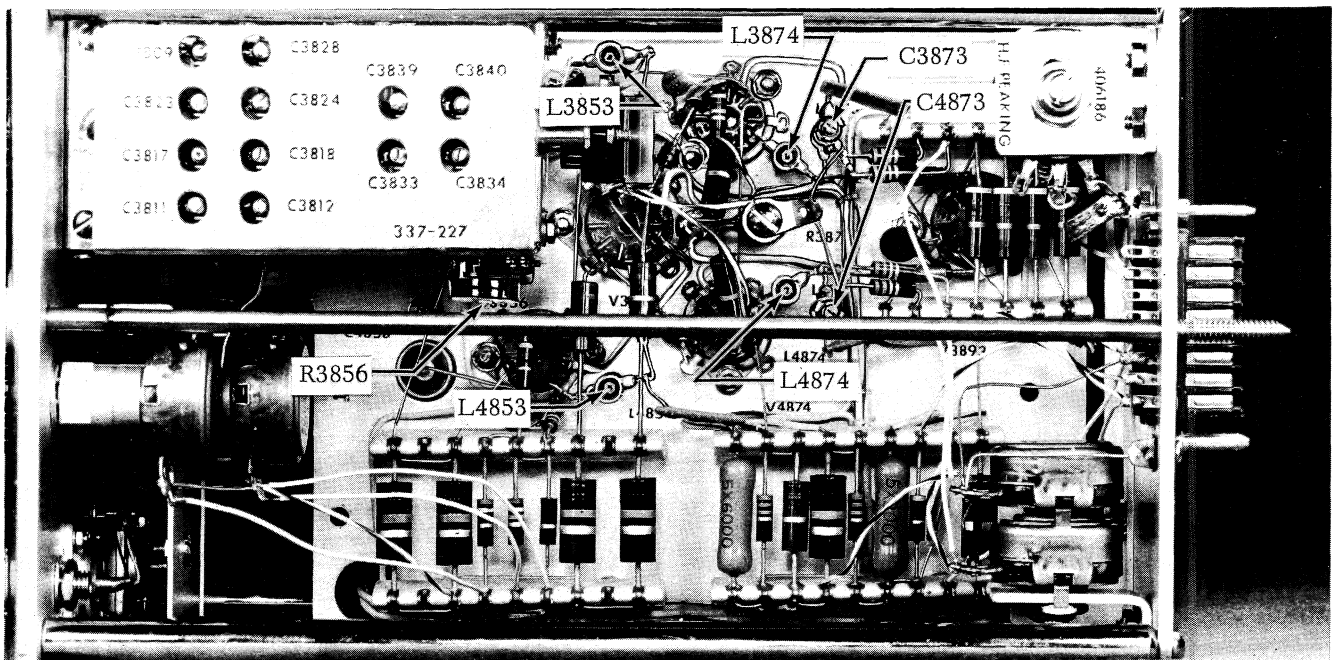

Fig. 5-5. Bottom view of Type H Unit (SN 101-1789) showing the location of adjustments.

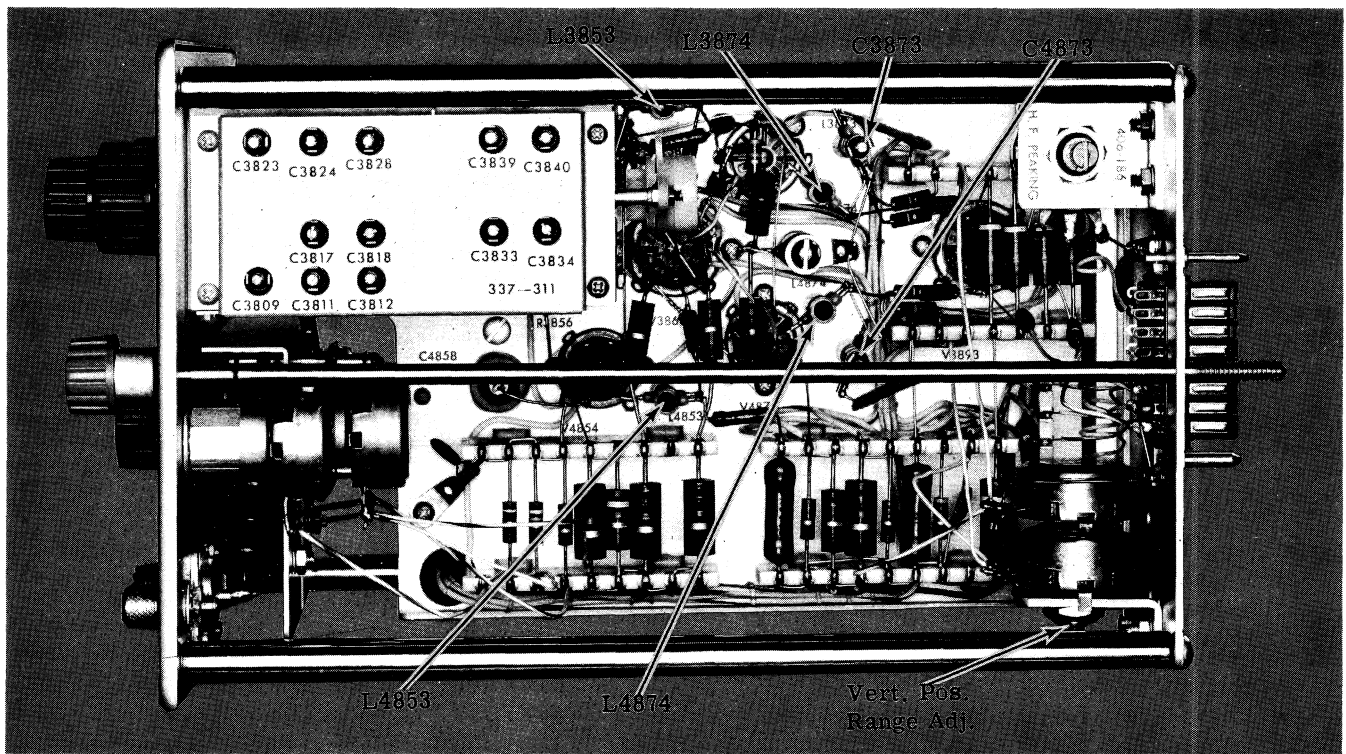

Fig. 5-6. Bottom view of Type H Unit (SN 1790-10,000) showing the location of adjustments.

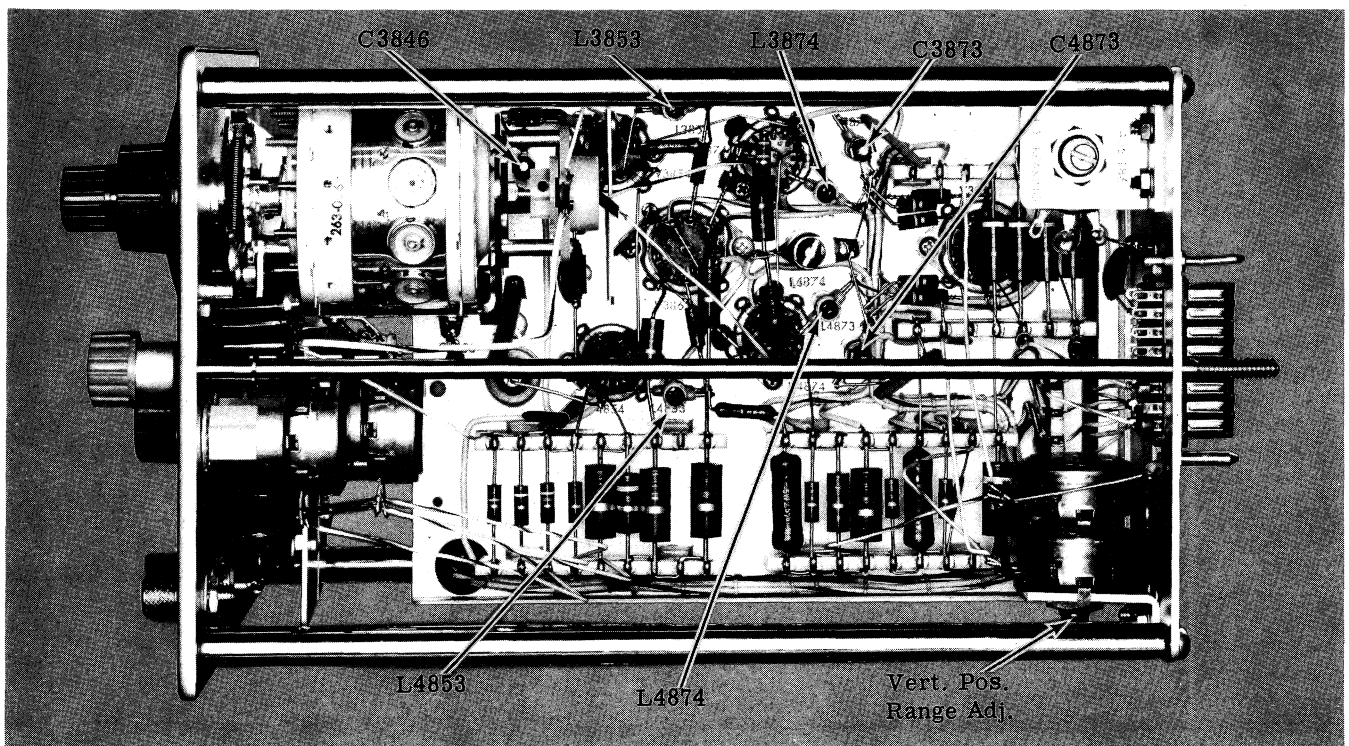

Fig. 5-7. Bottom view of Type H Unit (SN 10,001-10,769) showing the location of the turret and components.



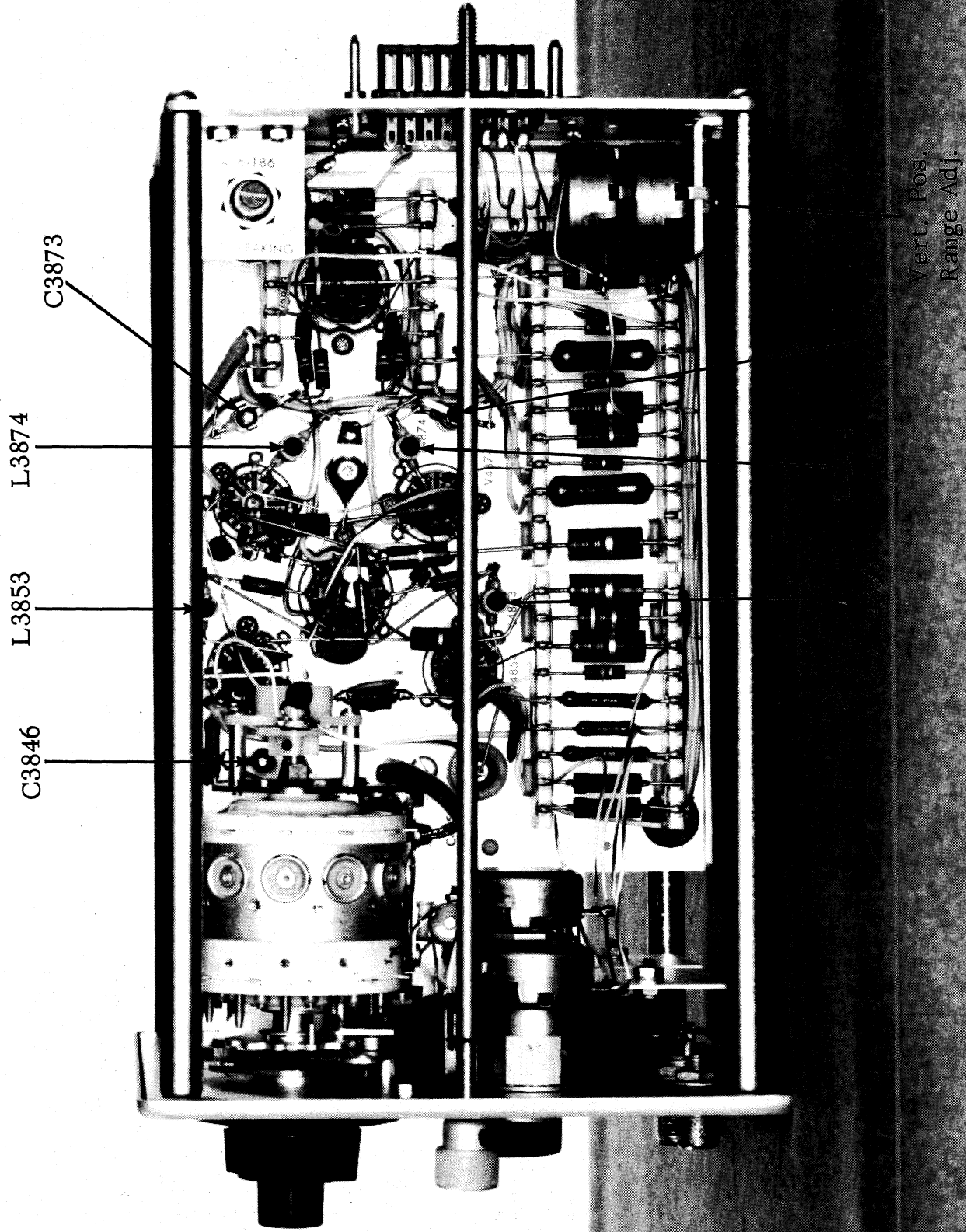

Fig. 5-8. Bottom view of Type H Unit (SN 10,770-up) showing the location of the turret and components.



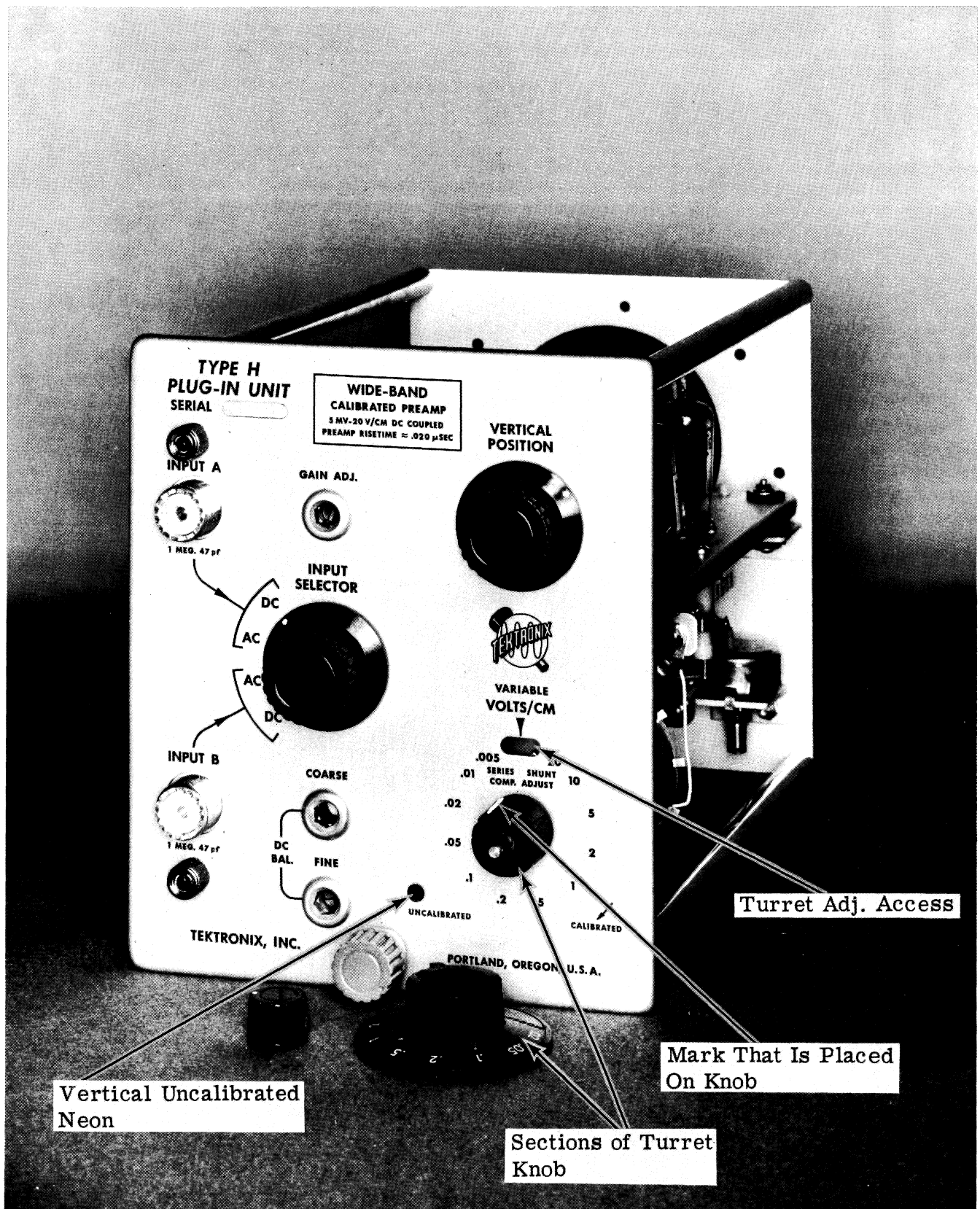
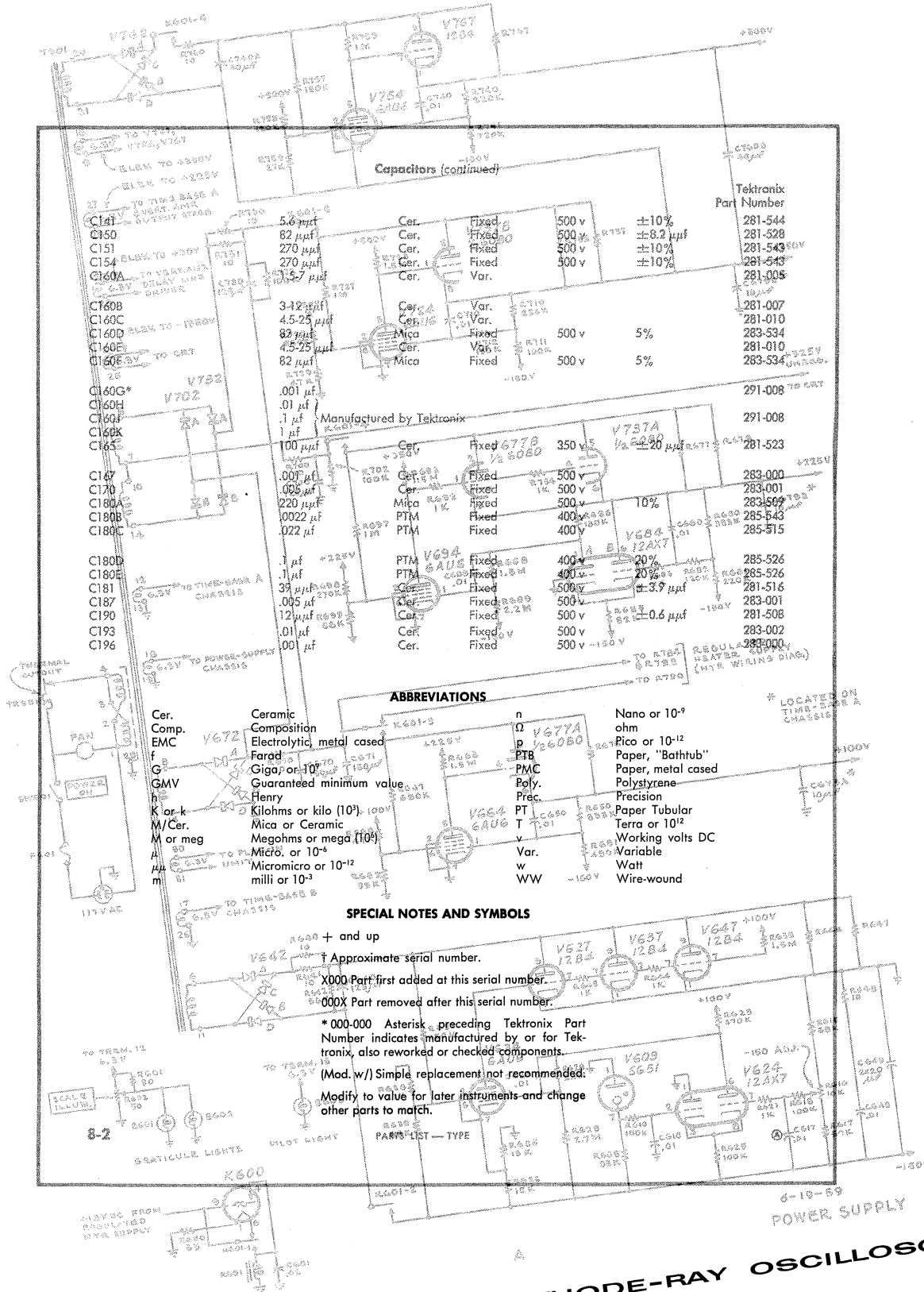

Fig. 5-9. Front panel view of Type H Unit (SN 10,001-up) showing the access through which the turret adjustments are made. The picture will also show you where to mark the turret knob, as explained in the Calibration Procedure.



# PARTS LIST and DIAGRAMS



**Capacitors (continued)**

Part Number	Value	Material	Voltage	Tolerance	Tektronix Part Number
C141	5.6 $\mu$ F	Cer.	500 v	$\pm 10\%$	281-544
C150	82 $\mu$ F	Cer.	500 v	$\pm 8.2\%$	281-528
C151	270 $\mu$ F	Cer.	500 v	$\pm 10\%$	281-543
C154	270 $\mu$ F	Cer.	500 v	$\pm 10\%$	281-543
C160A	100-27 $\mu$ F	Cer.	Var.		281-008
C160B	3-12 $\mu$ F	Cer.	Var.		281-007
C160C	4.5-25 $\mu$ F	Cer.	Var.		281-010
C160D	82 $\mu$ F	Mica	500 v	5%	283-534
C160E	4.5-25 $\mu$ F	Cer.	Var.		281-010
C160E	82 $\mu$ F	Mica	500 v	5%	283-534
C160G*	.001 $\mu$ F				291-008
C160H	.01 $\mu$ F				291-008
C160J	.1 $\mu$ F				291-008
C162K	100 $\mu$ F				281-523
C165	100 $\mu$ F				281-523
C167	.001 $\mu$ F				283-000
C170	.005 $\mu$ F				283-001
C180A	220 $\mu$ F				283-509
C180B	10022 $\mu$ F				285-543
C180C	.022 $\mu$ F				285-515
C180D	.1 $\mu$ F				285-526
C180E	.1 $\mu$ F				285-526
C181	39 $\mu$ F				281-516
C187	.085 $\mu$ F				283-001
C190	12 $\mu$ F				281-508
C193	.01 $\mu$ F				283-002
C196	.001 $\mu$ F				283-000

**ABBREVIATIONS**

Cer.	Ceramic Composition	n	Nano or 10 <sup>-9</sup> ohm
Comp.	Electrolytic, metal cased	0	Pico or 10 <sup>-12</sup>
EMC	Farad	p	Paper, "Bathtub"
f	Giga- or 10 <sup>9</sup>	PTB	Paper, metal cased
G	Giga- or 10 <sup>9</sup>	PMC	Polystyrene
GMV	Guaranteed minimum value	Poly.	Precision
h	Henry	Prec.	Paper Tubular
K or k	Kilohms or kilo (10 <sup>3</sup> )	PT	Terra or 10 <sup>12</sup>
M/Cer.	Mica or Ceramic	T	Working volts DC
M or meg	Megohms or mega (10 <sup>6</sup> )	v	Variable
A	Micro- or 10 <sup>-6</sup>	Var.	Watt
$\mu$ H	Micromicro or 10 <sup>-12</sup>	w	Watt
m	milli or 10 <sup>-3</sup>	WW	Wire-wound

**SPECIAL NOTES AND SYMBOLS**

- + and up
- † Approximate serial number.
- X000 Part first added at this serial number.
- 000X Part removed after this serial number.
- \* 000-000 Asterisk preceding Tektronix Part Number indicates manufactured by or for Tektronix, also reworked or checked components.
- (Mod. w/) Simple replacement not recommended.
- Modify to value for later instruments and change other parts to match.

MANUFACTURERS OF CATHODE-RAY OSCILLOSCOPES



## **HOW TO ORDER PARTS**

Replacement parts are available through your local Tektronix Field Office.

Improvements in Tektronix instruments are incorporated as soon as available. Therefore, when ordering a replacement part it is important to supply the part number including any suffix, instrument type, serial number, plus a modification number where applicable.

If the part you have ordered has been improved or replaced, your local Field Office will contact you if there is a change in part number.

# PARTS LIST

Values are fixed unless marked Variable.

## Bulbs

Ckt. No.	S/N Range	Description	Tektronix Part Number
B3877	X10,001-up	Neon, Type NE-2	150-002

## Capacitors

Tolerance  $\pm 20\%$  unless otherwise indicated.

C408B	X10,001-up	Adjusting Slug						214-142
C408C	X10,001-up	Adjusting Slug						214-084
C408D	X10,001-up	8 $\mu\mu\text{f}$	Cer.	Fixed	500 v	$\pm .5 \mu\mu\text{f}$	Use	281-503
C409A	X13440-up	2.7 $\mu\mu\text{f}$	Cer.	Fixed	500 v	10%		281-547
C409B	X10,001-up	Adjusting Slug						214-142
C409C	X10,001-up	Adjusting Slug						214-084
C410A	X13440-up	3.3 $\mu\mu\text{f}$	Cer.	Fixed	500 v	$\pm .25 \mu\mu\text{f}$		281-534
C410B	X10,001-up	Adjusting Slug						214-142
C410C	X10,001-up	Adjusting Slug						214-084
C410E	X10,001-up	10 $\mu\mu\text{f}$	Cer.	Fixed	500 v	10%		281-504
C411A	X13440-up	3.3 $\mu\mu\text{f}$	Cer.	Fixed	500 v	$\pm .25 \mu\mu\text{f}$		281-534
C411B	X10,001-up	Adjusting Slug						214-142
C411C	X10,001-up	Adjusting Slug						214-084
C411E	X10,001-up	22 $\mu\mu\text{f}$	Cer.	Fixed	500 v	10%		281-511
C412A	X13440-up	3.3 $\mu\mu\text{f}$	Cer.	Fixed	500 v	$\pm .25 \mu\mu\text{f}$		281-534
C412B	X10,001-up	Adjusting Slug						214-142
C412C	X10,001-up	Adjusting Slug						214-084
C412E	X10,001-up	39 $\mu\mu\text{f}$	Cer.	Fixed	500 v	10%		281-517
C413A	X13440-up	3.3 $\mu\mu\text{f}$	Cer.	Fixed	500 v	$\pm .25 \mu\mu\text{f}$		281-534
C413B	X10,001-up	Adjusting Slug						214-142
C413C	X10,001-up	Adjusting Slug						214-084
C413E	X10,001-up	100 $\mu\mu\text{f}$	Cer.	Fixed	500 v	10%		281-530
C414A	X13440-up	3.3 $\mu\mu\text{f}$	Cer.	Fixed	500 v	$\pm .25 \mu\mu\text{f}$		281-534
C414B	X10,001-up	Adjusting Slug						214-142
C414C	X10,001-up	Adjusting Slug						214-084
C414E†	X10,001-up	200 $\mu\mu\text{f}$	Mica	Fixed	500 v	10%		283-557
C415A	X13440-up	3.3 $\mu\mu\text{f}$	Cer.	Fixed	500 v	$\pm .25 \mu\mu\text{f}$		281-534
C415B	X10,001-up	Adjusting Slug						214-142
C415C	X10,001-up	Adjusting Slug						214-084
C415E†	X10,001-up	400 $\mu\mu\text{f}$	Mica	Fixed	500 v	10%		283-556
C416A	X13440-up	4.7 $\mu\mu\text{f}$	Cer.	Fixed	500 v	$\pm .5 \mu\mu\text{f}$		281-501
C416B	X10,001-up	Adjusting Slug						214-142
C416C	X10,001-up	Adjusting Slug						214-141
C416E†	X10,001-up	500 $\mu\mu\text{f}$	Mica	Fixed	500 v	10%		283-541
C417A	X13440-up	4.7 $\mu\mu\text{f}$	Cer.	Fixed	500 v	$\pm .5 \mu\mu\text{f}$		281-501
C417B	X10,001-up	Adjusting Slug						214-142
C417C	X10,001-up	Adjusting Slug						214-141
C417E†	X10,001-up	750 $\mu\mu\text{f}$	Mica	Fixed	500 v	10%		283-540
C418A	X10,001-up	4.7 $\mu\mu\text{f}$	Cer.	Fixed	500 v	$\pm .5 \mu\mu\text{f}$	Use	281-501
C418B	X10,001-up	Adjusting Slug						214-142
C418C	X10,001-up	Adjusting Slug						214-141
C418E†	X10,001-up	1000 $\mu\mu\text{f}$	Mica	Fixed	500 v	10%		283-563
C3801	X1780-up	.1 $\mu\text{f}$	PTM		600 v		Use	*285-603
C3802	X1780-up	.1 $\mu\text{f}$	PTM		600 v		Use	*285-603
C3804	101-1779X	.1 $\mu\text{f}$	PTM		600 v			285-528
C3805	X10,382-up	5.5-18 $\mu\mu\text{f}$	Cer.	Var.				281-061

† These capacitors are installed at the factory by a special process. If replacement is necessary, order a wired turret body, part number \*263-006.

Capacitors (continued)

						Tektronix Part Number	
C3806	X10,001-10,381	22 $\mu\text{mf}$	Cer.		500 v	5%	281-582
C3806	10382-up	10 $\mu\text{mf}$	Cer.		500 v	10%	281-504
C3808	101-1779	3.3 $\mu\text{mf}$	Cer.		500 v	$\pm 0.25 \mu\text{mf}$	281-534
	1780-10,000X	5.6 $\mu\text{mf}$	Cer.		500 v	10%	281-544
C3809	101-10,000X	.7-3 $\mu\text{mf}$	Tub.	Var.			281-027
C3810	101-1779	22 $\mu\text{mf}$	Cer.		500 v	10%	281-511
	1780-10,000X	24 $\mu\text{mf}$	Cer.		500 v	5%	281-564
C3811	101-10,000X	.7-3 $\mu\text{mf}$	Tub.	Var.			281-027
C3812	101-1779	.7-3 $\mu\text{mf}$	Tub.	Var.			281-027
	1780-10,000X	.7-3 $\mu\text{mf}$	Tub.	Var.			281-043
C3814	101-10,000X	8 $\mu\text{mf}$	Cer.		500 v	$\pm 0.5 \mu\text{mf}$	281-503
C3816	101-1779	22 $\mu\text{mf}$	Cer.		500 v	10%	281-511
	1780-10,000X	24 $\mu\text{mf}$	Cer.		500 v	5%	281-564
C3817	101-10,000X	.7-3 $\mu\text{mf}$	Tub.	Var.			281-027
C3818	101-1779	.7-3 $\mu\text{mf}$	Tub.	Var.			281-027
	1780-10,000X	.7-3 $\mu\text{mf}$	Tub.	Var.			281-043
C3820	101-1779	220 $\mu\text{mf}$	Mica		500 v	5%	283-513
	1780-10,000X	270 $\mu\text{mf}$	Cer.		500 v	10%	281-543
C3822	101-1779	22 $\mu\text{mf}$	Cer.		500 v	10%	281-511
	1780-10,000X	24 $\mu\text{mf}$	Cer.		500 v	5%	281-564
C3823	101-10,000X	.7-3 $\mu\text{mf}$	Tub.	Var.			281-027
C3824	101-1779	.7-3 $\mu\text{mf}$	Tub.	Var.			281-027
	1780-10,000X	.7-3 $\mu\text{mf}$	Tub.	Var.			281-043
C3826	101-1779	82 $\mu\text{mf}$	Cer.		500 v	10%	281-528
	1780-10,000X	27 $\mu\text{mf}$	Cer.		500 v		281-513
C3828	101-1779	.7-3 $\mu\text{mf}$	Tub.	Var.			281-027
	1780-10,000X	.7-3 $\mu\text{mf}$	Tub.	Var.			281-043
C3830	101-1779	220 $\mu\text{mf}$	Mica		500 v	5%	283-513
	1780-10,000X	270 $\mu\text{mf}$	Cer.			10%	281-543
C3832	101-1779	2.7 $\mu\text{mf}$	Cer.		500 v	10%	281-547
	1780-10,000X	2.2 $\mu\text{mf}$			500 v	$\pm 0.5 \mu\text{mf}$	281-500
C3833	101-10,000X	.7-3 $\mu\text{mf}$	Tub.	Var.			281-027
C3834	101-1779	.7-3 $\mu\text{mf}$	Tub.	Var.			281-027
	1780-10,000X	.7-3 $\mu\text{mf}$	Tub.	Var.			281-043
C3835	101-1779	10 $\mu\text{mf}$	Cer.		500 v	10%	281-504
	1780-10,000X	12 $\mu\text{mf}$	Cer.		500 v	10%	281-506
C3838	101-1779	6.8 $\mu\text{mf}$	Cer.		500 v	10%	281-541
	1780-10,000X	5.6 $\mu\text{mf}$	Cer.		500 v	10%	281-544
C3839	101-10,000X	.7-3 $\mu\text{mf}$	Tub.	Var.			281-027
C3840	101-1779	.7-3 $\mu\text{mf}$	Tub.	Var.			281-027
	1780-10,000X	.7-3 $\mu\text{mf}$	Tub.	Var.			281-043
C3841	X1780-10,000X	1.5 $\mu\text{mf}$	Cer.		500 v	1.5 $\mu\text{mf}$	281-529
C3846	X10,001-up	.7-3 $\mu\text{mf}$	Tub.	Var.			281-037
C3850	101-10,000	.005 $\mu\text{f}$	Discap		500 v		283-001
	10,001-up	.01 $\mu\text{f}$	Discap		150 v		283-003
C3855		.005 $\mu\text{f}$	Discap		500 v		283-001
C3873		.7-3 $\mu\text{mf}$	Tub.	Var.			281-027
C3875		.001 $\mu\text{f}$	Discap		500 v		283-000
C3877	X10,001-up	.001 $\mu\text{f}$	Discap		500 v		283-000
C3894		.001 $\mu\text{f}$	Discap		500 v		283-000
C4820	X10,001-up	.02 $\mu\text{f}$	Discap		150 v		283-004
C4821		.01 $\mu\text{f}$	Discap		150 v		283-003
C4823	101-1779X	.01 $\mu\text{f}$	Discap		150 v		283-003

Capacitors (continued)

Tektronix  
Part Number

C4825		.01 $\mu$ f	Discap		500 v		283-002
C4826	X10,001-up	.005 $\mu$ f	Discap		500 v		283-001
C4827		.005 $\mu$ f	Discap		500 v		283-001
C4842		.01 $\mu$ f	Discap		150 v		283-003
C4858		6.25 $\mu$ f	EMT		300 v	-20% +50%	290-000
C4873		.7-3 $\mu$ $\mu$ f	Tub.	Var.			281-027
C4875		.001 $\mu$ f	Discap		500 v		283-000
C4894		.001 $\mu$ f	Discap		500 v		283-000

Inductors

L3853		10-22 $\mu$ h		Var.	core 276-506		Use *114-125
L3861		2.5 $\mu$ h					*108-148
L3871		.45 $\mu$ h					*108-098
L3873		8.4 $\mu$ h					*108-149
L3874		11-23 $\mu$ h		Var.	core 276-506		*114-110
L3891		1.8 $\mu$ h					*108-105
L3896		.18 $\mu$ h					*108-009
L4853		10-22 $\mu$ h		Var.	core 276-506		Use *114-125
L4861		2.5 $\mu$ h					*108-148
L4871		.45 $\mu$ h					*108-098
L4873		8.4 $\mu$ h					*108-149
L4874		11-23 $\mu$ h		Var.	core 276-506		*114-110
L4891		1.8 $\mu$ h					*108-105
L4896		.18 $\mu$ h					*108-009

Resistors

Resistors are fixed, composition,  $\pm 10\%$  unless otherwise indicated.

R408C	X10,001-up	500 k	$\frac{1}{2}$ w	Prec.	1%	309-140
R408E	X10,001-up	1 meg	$\frac{1}{8}$ w	Prec.	1%	318-004
R409C	X10,001-up	750 k	$\frac{1}{2}$ w	Prec.	1%	309-141
R409E	X10,001-up	333 k	$\frac{1}{8}$ w	Prec.	1%	318-005
R410C	X10,001-up	900 k	$\frac{1}{2}$ w	Prec.	1%	309-142
R410E	X10,001-up	111 k	$\frac{1}{8}$ w	Prec.	1%	318-006
R411C	X10,001-up	950 k	$\frac{1}{2}$ w	Prec.	1%	309-143
R411E	X10,001-up	52.6 k	$\frac{1}{8}$ w	Prec.	1%	318-007
R412C	X10,001-up	975 k	$\frac{1}{2}$ w	Prec.	1%	309-144
R412E	X10,001-up	25.6 k	$\frac{1}{8}$ w	Prec.	1%	318-008
R413C	X10,001-up	990 k	$\frac{1}{2}$ w	Prec.	1%	309-145
R413E	X10,001-up	10.1 k	$\frac{1}{8}$ w	Prec.	1%	318-009
R414C	X10,001-up	995 k	$\frac{1}{2}$ w	Prec.	1%	309-146
R414E	X10,001-up	5.03 k	$\frac{1}{8}$ w	Prec.	1%	318-010
R415C	X10,001-up	997.5 k	$\frac{1}{2}$ w	Prec.	1%	309-147
R415E	X10,001-up	2.51 k	$\frac{1}{8}$ w	Prec.	1%	318-011
R416C	X10,001-up	1 meg	$\frac{1}{4}$ w	Prec.	1%	319-031
R416E	X10,001-up	1 k	$\frac{1}{8}$ w	Prec.	1%	318-049
R417C	X10,001-up	1 meg	$\frac{1}{4}$ w	Prec.	1%	319-031
R417E	X10,001-up	500 $\Omega$	$\frac{1}{8}$ w	Prec.	1%	318-037



Resistors (continued)

							Tektronix Part Number
R418C	X10,001-up	1 meg	1/4 w		Prec.	1%	319-031
R418E	X10,001-up	250 Ω	1/8 w		Prec.	1%	318-064
R3801		27 Ω	1/2 w				302-270
R3802		27 Ω	1/2 w				302-270
R3804	X1780-up	47 Ω	1/2 w				302-470
R3805	X10,001-up	47 Ω	1/2 w				302-470
R3806	X10,001-up	27 Ω	1/2 w				302-270
R3812	101-10,000X	900 k	1/2 w		Prec.	1%	309-142
R3814	101-10,000X	111 k	1/2 w		Prec.	1%	309-138
R3818	101-10,000X	990 k	1/2 w		Prec.	1%	309-145
R3820	101-10,000X	10.1 k	1/2 w		Prec.	1%	309-135
R3824	101-1779	970 k	1/2 w		Prec.	1%	309-012
	1780-10,000X	900 k	1/2 w		Prec.	1%	309-142
R3826	101-1779	34.5 k	1/2 w		Prec.	1%	309-038
	1780-10,000X	111 k	1/2 w		Prec.	1%	309-138
R3828	101-1779	300 k	1/2 w		Prec.	1%	309-125
	1780-10,000X	990 k	1/2 w		Prec.	1%	309-145
R3830	101-10,000X	10.1 k	1/2 w		Prec.	1%	309-135
R3834	101-10,000X	500 k	1/2 w		Prec.	1%	309-140
R3836	101-10,000X	1 meg	1/2 w		Prec.	1%	309-148
R3840	101-10,000X	750 k	1/2 w		Prec.	1%	309-141
R3842	101-10,000X	333 k	1/2 w		Prec.	1%	309-139
R3844	101-10,000X	47 Ω	1/2 w				302-470
R3846		1 meg	1/2 w		Prec.	1%	309-148
R3850	101-10,000	100 k	1/2 w				302-104
	10,001-up	1 meg	1/4 w				316-105
R3851	101-10,000X	47 Ω	1/2 w				302-470
	10,001-up	47 Ω	1/4 w				316-470
R3852		6 k	5 w		WW	5%	308-052
R3853		1.4 k	1/2 w		Prec.	1%	Use 309-274
R3855	101-1779	12 Ω	1/2 w				302-120
	1780-up	16 Ω	1/2 w			5%	301-160
R3856	101-949	500 Ω	.10 w	Var.		.05 μsec. RC Comp. Use	311-129
	950-1779	150 Ω	.1 w	Var.		.05 μsec. RC Comp.	311-129
	1780-up	16 Ω	1/2 w			5%	301-160
R3857	101-1779	22 k	2 w				306-223
	1780-up	15 k	2 w				306-153
R3858	101-1779	22 k	2 w				306-223
	1780-up	39 k	1 w				304-393
R3865		6.8 k	1 w				304-682
R3866		15 k	2 w				306-153
R3873		3 k	5 w		WW	5%	308-062
R3874		1.6 k	1/2 w		Mica Plate	1%	*310-550
R3875		470 k	1/2 w				302-474
R3876	101-2639	5.6 k	1 w				Use 303-562
	2640-up	5.6 k	1 w			5%	303-562
R3877	X10,001-up	180 k	1/2 w				302-184
R3878	101-10,000	660 Ω		Var.	WW	VARIABLE	*311-140
	10,001-up	780 Ω		Var.	WW	VARIABLE	Use *311-288
R3879		4.5 k	5 w		WW	5%	308-066

## Resistors (continued)

Tektronix  
Part Number

R3880		10 k	2 w	Var.		GAIN ADJ.	311-016
R3883		330 k	1/2 w				302-334
R3885		2 x 100 k	2 w	Var.		VERT. POS	311-028
R3886		2 x 100 k	2 w	Var.		VERT. POS.	311-051
R3887		330 k	1/2 w				302-334
R3893		3.9 k	2 w				306-392
R3894		9.1 k	1 w			5%	303-912
R3896		9.1 k	1 w			5%	303-912
R3897		2 k	2 w	Var.		H.V. PEAKING	311-008
R4827		47 Ω	1/2 w				302-470
R4831		100 k	2 w	Var.		DC Bal. Coarse	311-026
R4832	X10,770-up	50 k	1/2 w		Prec.	1%	309-090
R4833	101-10769	390 k	1/2 w				302-394
R4833	10,770-up	390 k	1/2 w		Prec.	1%	309-056
R4834	X10,770-up	50 k	1/2 w		Prec.	1%	309-090
R4835		100 k	2 w	Var.		DC Bal. Fine	311-026
R4837	101-10,769	3.9 meg	1/2 w				302-395
R4837	10,770-up	4 meg	1/2 w		Prec.	1%	309-093
R4841	101-10,769	1.5 meg	1/2 w				302-155
R4841	10,770-up	2.5 meg	1/2 w		Prec.	1%	309-025
R4842	101-10,769	3.9 k	1/2 w				302-392
R4842	10,770-up	2.51 k	1/2 w		Prec.	1%	309-133
R4851		47 Ω	1/2 w				302-470
R4853		1.4 k	1/2 w		Prec.	1%	Use 309-274
R4857		15 k	2 w				306-153
R4858		33 k	1/2 w				302-333
R4865		6.8 k	1 w				304-682
R4866		15 k	2 w				306-153
R4874		1.6 k	1/2 w		Mica Plate	1%	*310-550
R4875		470 k	1/2 w				302-474
R4876	101-2639	5.6 k	1 w				Use 303-562
	2640-up	5.6 k	1 w			5%	303-562
R4879		5.6 k	1 w				304-562
R4880		33 k	1/2 w				302-333
R4882	X13510-up	18 k	1/2 w			5%	301-183
R4883		330 k	1/2 w				302-334
R4887		330 k	1/2 w				302-334
R4894		9.1 k	1 w			5%	303-912
R4896		9.1 k	1 w			5%	303-912

## Switches

			Unwired	Wired
SW3800	101-1779	INPUT SELECTOR	*260-081	*262-155
	1780-10,000	INPUT SELECTOR	*260-285	*262-246
	10-001-10381	INPUT SELECTOR	*260-285	*050-049
	10382-up	INPUT SELECTOR	*260-285	*262-439
SW3810	101-177 <sup>c</sup>	VOLTS/CM	*260-213	*262-154
	1780-10,000X	VOLTS/CM	*260-277	*262-247
SW3877	X10,001-up	TURRET ATTENUATOR, COMPLETE		*263-006
	X13255-up	TURRET BODY, WIRED†		*204-130

† Below S/N 13255 order for wired turret body \*263-006.

## Electron Tubes

Tektronix  
Part Number

V3854 †	12AU6	Use *157-076
V3863	12AT7	154-039
V3874 ††	12AU6	Use *157-078
V3893	12AT7	154-039
V4854 †	12AU6	Use *157-076
V4874 ††	12AU6	Use *157-078

† V3854 and V4854 are a selected pair of tubes. Furnished as a unit.

†† V3874 and V4874 are a selected pair of tubes. Furnished as a unit.

# Type H Mechanical Parts List

	Tektronix Part Number
BODY, CAPACITOR BARREL FOR TURET ATTEN., BRASS SN 10,001-13254	204-024
BODY, CAPACITOR BARREL FOR TURRET ATTEN., BRASS 13255-up	204-127
BODY, REAR TURRET ATTEN. SN 10,001-up	204-025
BODY, FRONT TURRET ATTEN. SN 10,001-up	204-026
BRACKET, VER. POS. RANGE, MTG. POT	406-127
BRACKET, "HF PEAKING"	406-186
BRACKET, REAR SHOCKMOUNT	406-369
BRACKET, FRONT SHOCKMOUNT SN 101-10,000	406-370
BRACKET, FRONT SHOCKMOUNT SN 10,001-up	406-591
BUSHING $\frac{3}{8}$ -32 x $\frac{7}{16}$ x .412	358-010
CABLE HARNESS SN 101-10,000	179-224
CABLE HARNESS SN 10,001-10769	179-451
CABLE HARNESS SN 10770-up	179-581
CARRIER, DETENT TURRET SN 10,001-up	214-087
CHASSIS SN 101-10,000	441-192
CHASSIS SN 10,001-10769	441-325
CHASSIS SN 10770-up	441-409
CLAMP, CABLE $\frac{7}{16}$ , Plastic	343-005
CLAMP, CABLE $\frac{1}{2}$ , Plastic	343-006
CLAMP, CABLE $\frac{5}{8}$ , Plastic SN 101-10,000	343-007
CLAMP, CABLE $\frac{1}{2}$ , ID STEEL	343-015
CONNECTOR, CHASSIS MTD., COAX, 1 contact, female SN 101-10,000	131-012
CONNECTOR, CHASSIS MTD., COAX, 1 contact, female $\frac{1}{2}$ " "D" hole SN 10,001-13359	131-081
CONNECTOR, CHASSIS MTD., COAX. BNC SN 13360-up	131-126
CONNECTOR, CHASSIS MTD., AMPH., 16 contact, male	131-017
CONTACT BOARD SN 10001-13254	Use 050-095
CONTACT BOARD SN 13255-up	387-694
CONTACT, TURRET ATTEN. SN 10,001-up	214-089
CONTACT, GROUND SN 10,001-up	214-131
EYELET, .088 x .166 SN 10,001-up	210-654
EYELET, .065 x .155 SN 10,001-up	210-656
FRAME, TURRET ATTEN. SN 10,001-up	426-076
GROMMET, $\frac{3}{8}$ " RUBBER	348-004
HOLDER, NEON BULB, SINGLE SN 10,001-up	352-008
KNOB, SMALL RED .780 x .451 $\frac{1}{8}$ " hole part way SN 101-10,000	366-038
KNOB, SMALL RED .620 x .468 w/ $\frac{7}{16}$ hole SN 10,001-up	366-081
KNOB, LARGE BLACK $\frac{1}{4}$ " hole thru SN 101-10,000	366-040
KNOB, LARGE BLACK $\frac{1}{4}$ " hole part way	366-042

Mechanical Parts List (continued)

	Tektronix Part Number
KNOB ASS'Y (366-238 & 366-241) SN 10001-up	Use 366-243
KNOB, OUTER SN 10001-up	Use 366-238
KNOB, INNER SN 10001-12953	Use 366-243
KNOB, INNER SN 12954-up	366-241
KNOB, PLUG-IN SECURING $\frac{9}{16} \times \frac{5}{8}$ w/ $\frac{3}{16}$ hole alum.	366-125
LOCKWASHER, STEEL EXT. #2	210-002
LOCKWASHER, STEEL EXT. #4	210-003
LOCKWASHER, STEEL INT. #4	210-004
LOCKWASHER, STEEL INT. #6	210-006
LOCKWASHER, STEEL INT. #8	210-008
LOCKWASHER, STEEL INT. $\frac{1}{4}$	210-011
LOCKWASHER, STEEL $\frac{3}{8} \times \frac{1}{2}$ , POT.	210-012
LOCKWASHER, STEEL $\frac{3}{8} \times 1\frac{1}{16}$	210-013
LOCKWASHER $\frac{1}{4}$ INT	210-046
LUG, SOLDER SE4	210-201
LUG, SOLDER SE6 w/2 wire holes	210-202
LUG, SOLDER SE8	210-205
LUG, SOLDER POT., PLAIN, $\frac{3}{8}$	210-207
NUT, HEX 2-56 x $\frac{3}{16}$	210-405
NUT, HEX 4-40 x $\frac{3}{16}$	210-406
NUT, HEX 6-32 x $\frac{1}{4}$	210-407
NUT, HEX 8-32 x $\frac{5}{16}$	210-409
NUT, HEX $\frac{3}{8}$ -32 x $\frac{1}{2}$	210-413
NUT, HEX BUSHING, $\frac{3}{8}$ -32 x $\frac{1}{2}$ x $1\frac{1}{16}$	210-429
NUT, HEX $\frac{1}{4}$ -28 x $\frac{3}{8}$ x $\frac{3}{32}$	210-455
NUT, KEPS 6-32 x $\frac{5}{16}$	210-457
NUT, HEX ALUM., 6-32 x $\frac{5}{16}$	210-478
NUT, HEX $\frac{3}{8}$ -32 x $\frac{1}{2}$ x $1\frac{1}{16}$	210-494
PANEL, FRONT SN101-10,000	use 333-515
PANEL, FRONT SN 10,001-up	333-613
PIN, COTTER SN 10,001-up	214-085
PIN, ROLL $\frac{1}{16} \times \frac{1}{4}$ SN 10,001-up	214-110
PLATE, SUB-PANEL SN 101-10,000	386-349
PLATE, SUB-PANEL SN 10,001-up	387-251
PLATE, PLEXIGLAS, .100 x $1\frac{7}{8}$ x $3\frac{3}{16}$ SN 101-1779	386-808
PLATE, TEXOLITE, .100 x $1\frac{7}{8}$ x $3\frac{3}{16}$ SN 1780-10,000	386-925
PLATE, TEXOLITE, CONTACT, $\frac{1}{16} \times 1.625 \times 1.031$ SN 10,001-up	386-940
PLATE, ALUM., .091 x $5\frac{1}{32}$ x $6\frac{1}{32}$	387-529
POST, BINDING	129-053

**Mechanical Parts List (continued)**

	Tektronix Part Number
RING, RETAINING, #18 SECURING, STEEL	354-025
RING, SECURING, POLY, 1/2 ID x 3/16 OD x 1/2 hi.	354-068
RING, "C" 1/4" dia. shaft SN 10,001-up	354-092
RING, GROUND, w/5 holes	354-102
ROD, EXTENSION SN 10,001-up	384-189
ROD, FRAME 3/8 x 87/8	384-508
ROD, NYLON 1/4 x 3/4 Tap 4-40 SN 10770-up	385-107
ROD, SECURING 3/16 x 10 1/2	384-510
ROD, HEX 1/2 x 1 5/16 Tap 3/8-32 (Replaces 166-131)	385-158
ROLLER, DETENT 5/16 x 1/8 SN 10,001-up	214-086
SCREW 4-40 x 1/8 BHS	211-005
SCREW 4-40 x 3/16 BHS	211-007
SCREW 4-40 x 1/4 BHS	211-008
SCREW 4-40 x 5/16 BHS	211-011
SCREW 4-40 x 3/4 RHS	211-017
SCREW 4-40 x 7/8 RHS	211-018
SCREW 4-40 x 1 FHS	211-031
SCREW 4-40 x 5/16 PAN HS w/lockwasher	211-033
SCREW 4-40 x 5/16 FHS, Phillips	211-038
SCREW 6-32 x 1/4 BHS	211-504
SCREW 6-32 x 5/16 BHS	211-507
SCREW 6-32 x 3/8 BHS	211-510
SCREW 6-32 x 1/2 BHS	211-511
SCREW 6-32 x 5/16 FHS	211-538
SCREW 6-32 x 3/4 THS	211-544
SCREW 6-32 x 3/8 FHS, 100°, CSK, Phillips	211-559
SCREW 6-32 x 9/32 CRS, Shoulder screw	211-563
SCREW 8-32 x 1 1/2 RHS	212-022
SCREW 8-32 x 1/2 FHS, 100°, Phillips	212-043
SCREW 8-32 x 1/2 RHS, Phillips	212-044
SCREW, THREAD CUTTING 4-40 x 5/16 RHS, Phillips	213-034
SCREW, THREAD CUTTING 4-40 x 1/2 PHS, Phillips	213-035
SCREW #0 x 1/8, Drive type, spiral	213-038
SCREW, THREAD CUTTING 5-32 x 3/16 PHS, Phillips	213-044
SCREW, SET 4-4 x 1/8 HHS, Allen Head	213-048
SHIELD, V/CM SWITCH 2 3/8 x 3 11/32 x 1 5/16 SN 101-1779	337-227
SHIELD, V/CM SWITCH 1 7/8 x 1 9/16 x 5/16 SN 101-1779	337-229
SHIELD, V/CM SWITCH 5/8 x 1 3/4 SN 101-10,000	337-231
SHIELD, V/CM SWITCH 2 3/16 x 2 5/16 SN 101-1779	337-233

**Mechanical Parts List (continued)**

	Tektronix Part Number
SHIELD, ATTEN. $1\frac{1}{8} \times 2\frac{1}{16} \times \frac{1}{2}$ SN 101-1779	337-235
SHIELD, ATTEN. FRONT SN 1780-10,000	337-306
SHIELD, ATTEN. SIDE SN 1780-10,000	337-307
SHIELD, ATTEN. BACK SN 1780-10,000	337-308
SHIELD $.032 \times 1\frac{7}{8} \times 3$ SN 1780-10,000	337-310
SHIELD, ATTEN. TOP SN 1780-10,000	337-311
SHIELD, ATTEN. $.040 \times 1\frac{3}{16} \times 2\frac{1}{16}$ SN 1780-10,000	337-312
SHIELD, TUBE, $.040 \times \frac{9}{16} \times 1 \times 2$ SN 10,001-up	337-376
SHOCKMOUNT, $\frac{1}{2}'' \times \frac{5}{8}''$ , Rubber	348-007
SLUG, ADJUSTING, 1.540 long w/4-40 thread one end SN 10,001-up	214-084
SLUG, ADJUSTING, 1.210 x .132 w/4-40 thread one end SN 10,001-up	214-141
SLUG, ADJUSTING, 1.540 x .139 w/4-40 thread one end SN 10,001-up	214-142
SOCKET STM7G	136-008
SOCKET STM9G	136-015
SPACER, NYLON, FOR CERAMIC STRIP	361-009
SPRING, EXTENSION .020 wire x $1\frac{1}{8}$ SN 10,001-up	214-088
SPRING, THRUST $.020 \times 1\frac{3}{8} \times \frac{5}{8}$ SN 10,001-up	214-134
STEM, BINDING POST ADAPTOR	355-507
STRIP, CERAMIC $\frac{3}{4} \times 4$ notches, clip mounted	124-088
STRIP, CERAMIC $\frac{3}{4} \times 7$ notches, clip mounted	124-089
STRIP, CERAMIC $\frac{3}{4} \times 9$ notches, clip mounted	124-090
STRIP, GROUND STRAP FRAME, $\frac{7}{32} \times 1\frac{5}{16}$	124-116
TAG, S/N INSERT	334-679
TUBE, SPACING, ALUM., $.118 \times \frac{5}{32} \times 1\frac{1}{16}$	166-106
TUBE, SPACING, ALUM., $.384 \times \frac{1}{2} \times \frac{9}{32}$ (See ROD 385-158)	166-131
TUBE, #4 SPACER, $\frac{9}{16}''$ long SN 10,001-up	166-169
TUBING, TEFLON, .1475 OD w/.008 wall	162-027
TUBING, PLASTIC INSUL., #20 black (skein)	162-504
WASHER, STEEL 5S x $\frac{9}{32} \times .025$	210-801
WASHER, STEEL 6L x $\frac{3}{8} \times .032$	210-804
WASHER, STEEL $.390 \times \frac{9}{16} \times .020$	210-840
WASHER, STEEL $.093 \times \frac{9}{32} \times .020$ #2 flat	210-850
WASHER, STEEL $.119 \times \frac{3}{8} \times .025$ #4L flat	210-851
WASHER, POLY. $.190 \times \frac{7}{16} \times \frac{1}{32}$	210-894
WASHER, STEEL .115 ID x $1\frac{5}{32}$ OD x .025	210-958
WHEEL, DETENT, ASS'Y SN 10,000-up	401-020



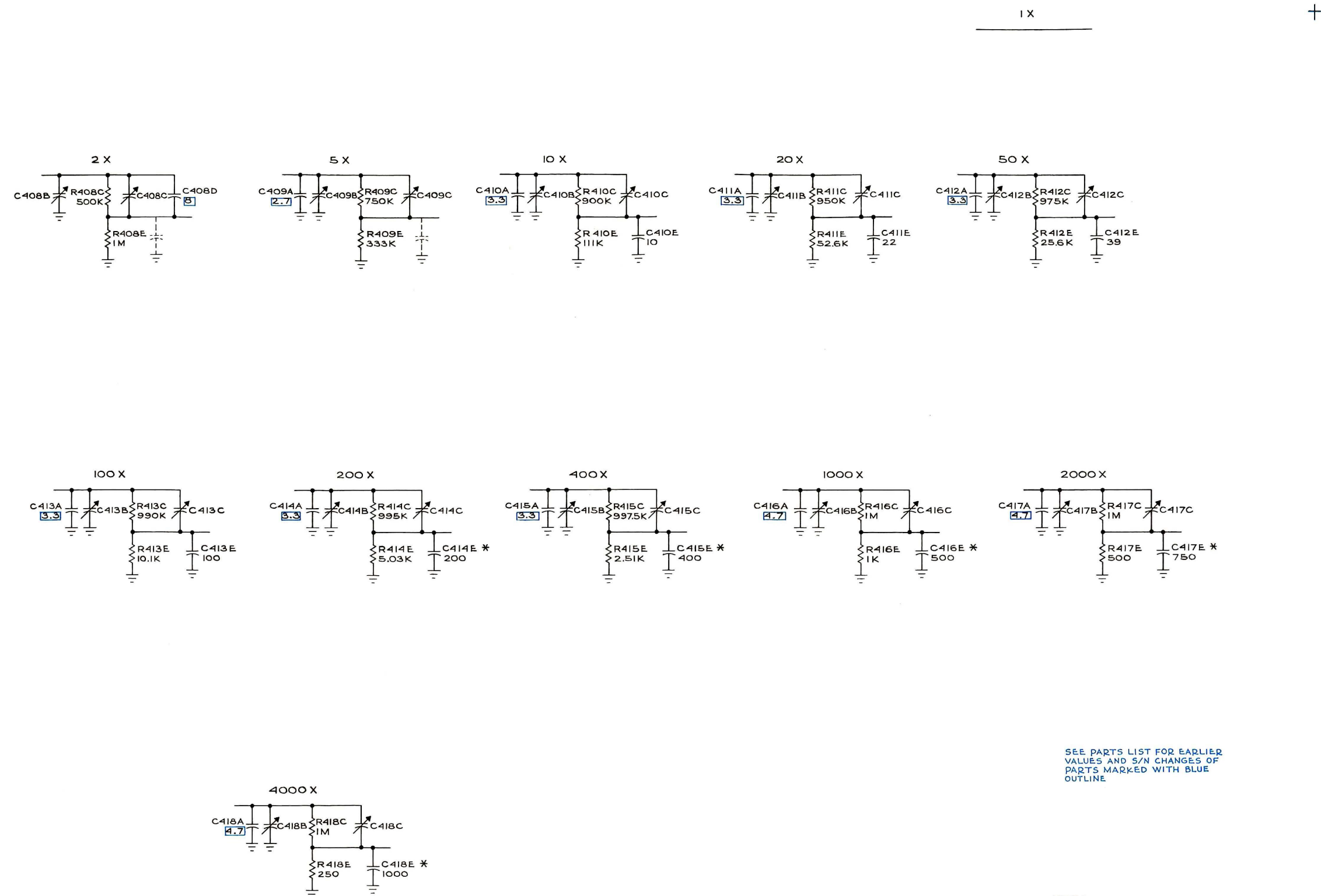

SEE PARTS LIST FOR EARLIER VALUES AND S/N CHANGES OF PARTS MARKED WITH BLUE OUTLINE

NOTE:  
 ALL VARIABLE CAPACITORS ARE .132-.008 pf  
 \* SILVERED MICA BUTTON CAPACITORS

TYPE 'H' PLUG-IN

AD<sub>1</sub>

CMD  
 463  
 TURRET ATTENUATOR  
 S/N 10,001-UP

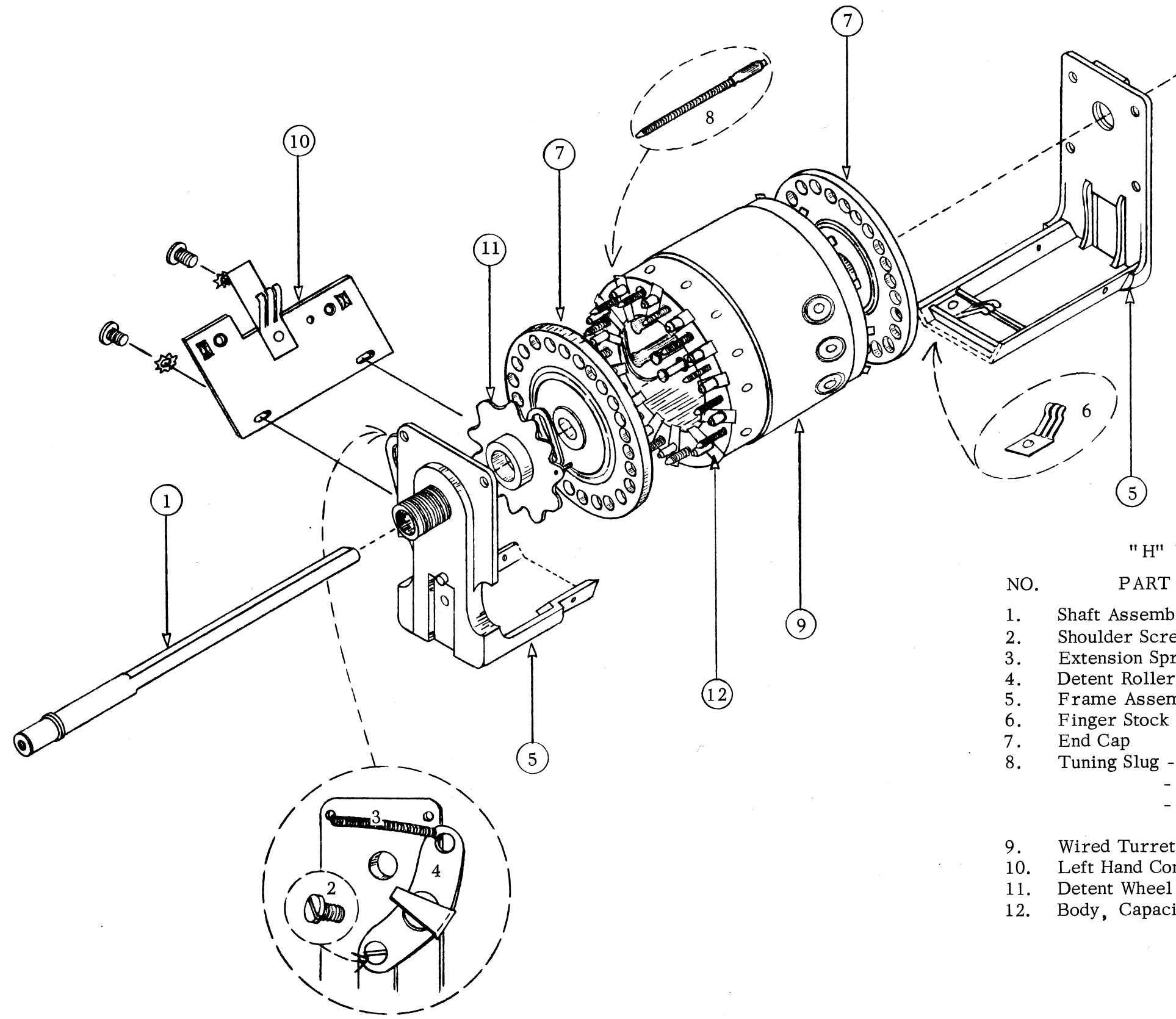

"H" Unit Turret Attenuator

NO.	PART	TEKTRONIX PART NO.
1.	Shaft Assembly	384-235
2.	Shoulder Screw	211-563
3.	Extension Spring	214-088
4.	Detent Roller Carrier Assembly	214-189
5.	Frame Assembly	426-125
6.	Finger Stock	214-131
7.	End Cap	200-191
8.	Tuning Slug - Gold .008 Teflon	214-216
	- Silver .004 Teflon	214-217
	- Gold 1/2 length, no Teflon	Supplied on Request
9.	Wired Turret Body Assembly	204-072
10.	Left Hand Contact Plate Assembly	387-423
11.	Detent Wheel Assembly	401-020
12.	Body, Capacitor Barrel	204-024

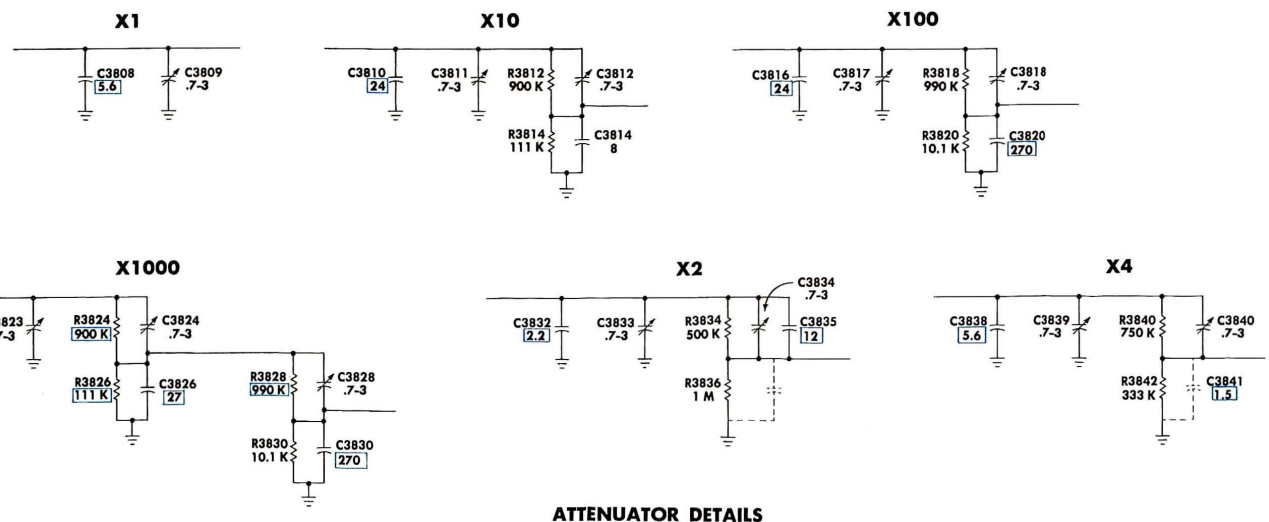
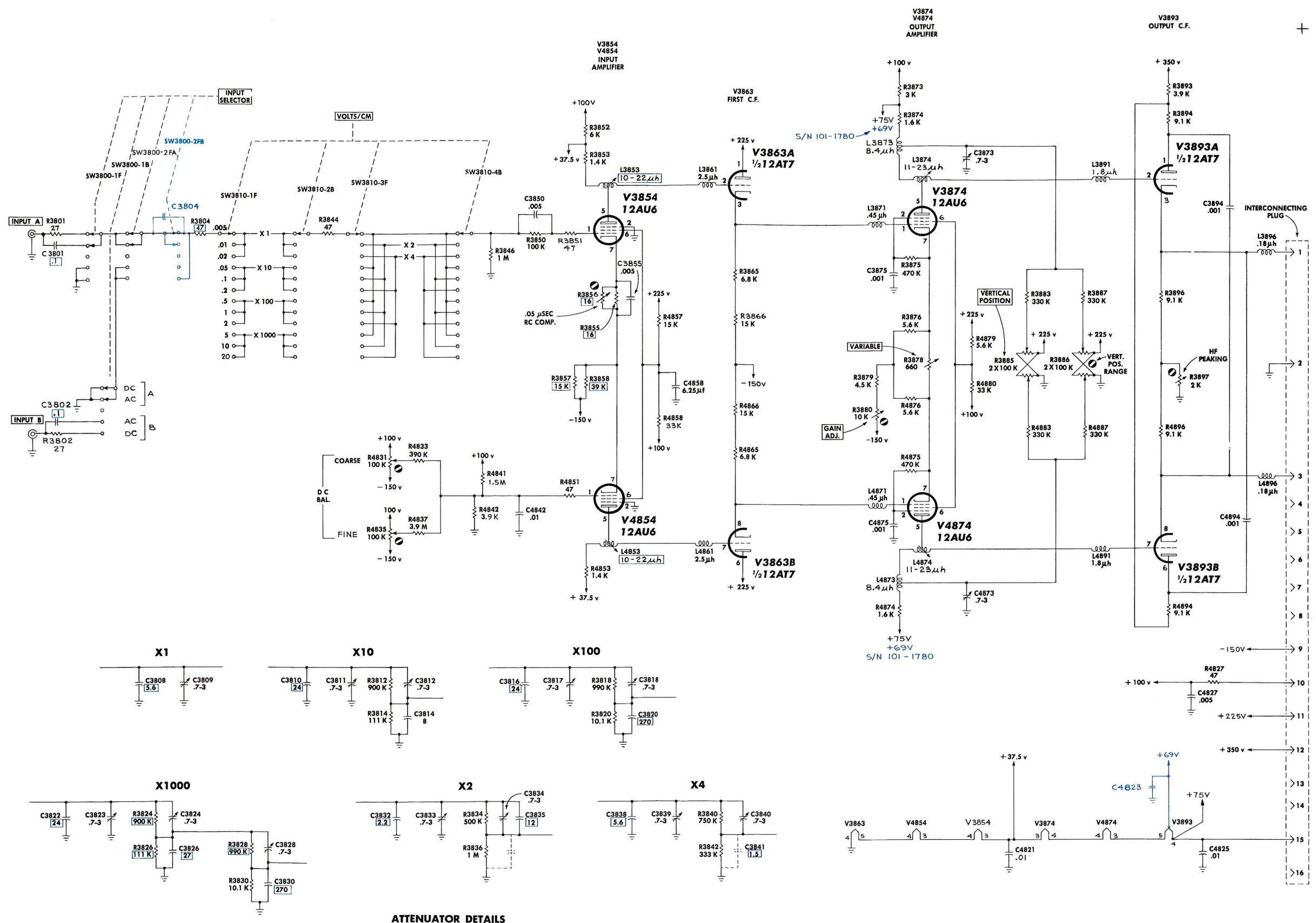

SEE PARTS LIST FOR EARLIER VALUES AND S/N CHANGES OF PARTS MARKED WITH BLUE OUTLINE

2 - 16 - 61  
TYPE H PREAMP  
S/N 101 - 10,000

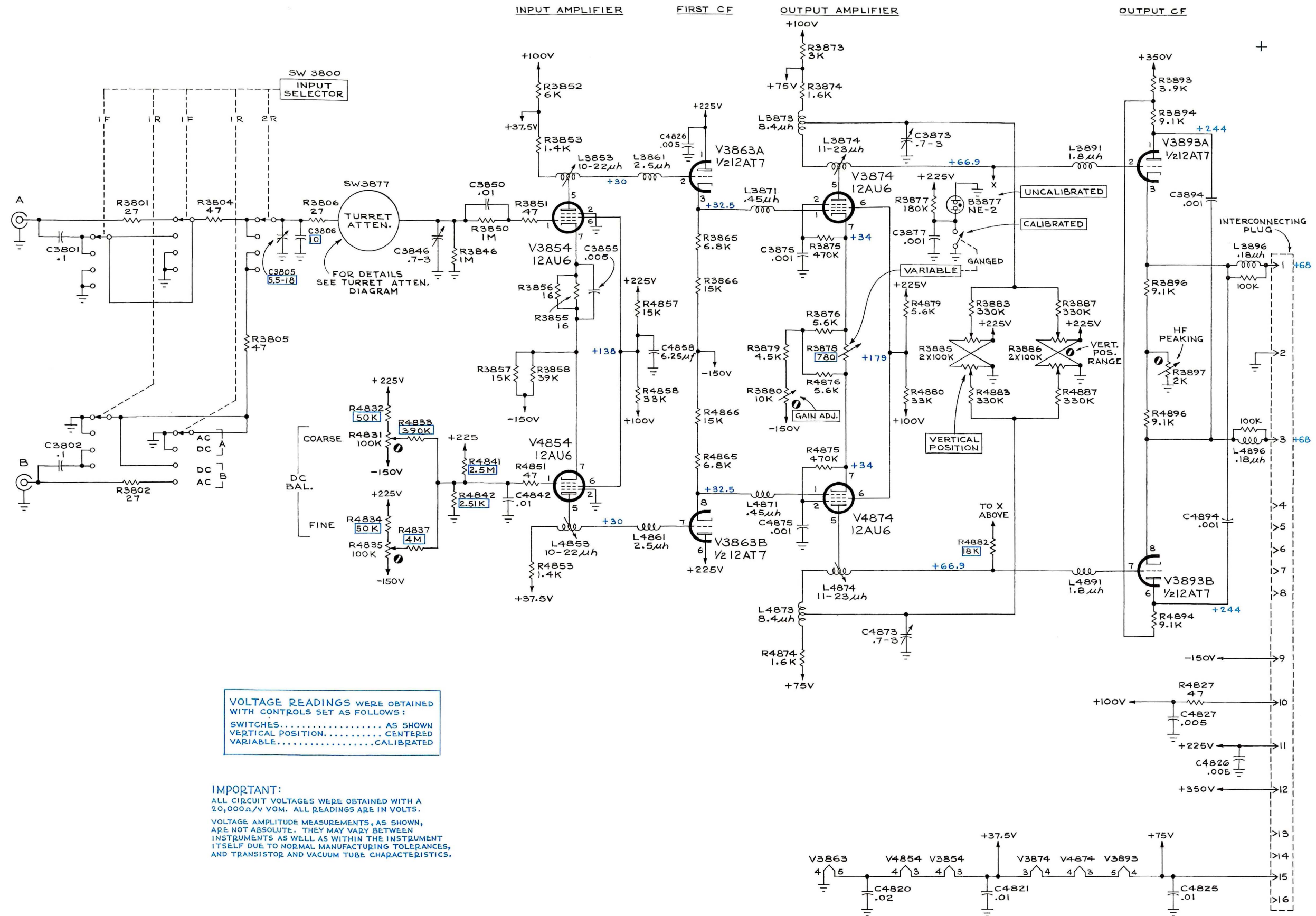

VOLTAGE READINGS WERE OBTAINED WITH CONTROLS SET AS FOLLOWS:  
 SWITCHES..... AS SHOWN  
 VERTICAL POSITION..... CENTERED  
 VARIABLE..... CALIBRATED

IMPORTANT:  
 ALL CIRCUIT VOLTAGES WERE OBTAINED WITH A 20,000Ω/V VOM. ALL READINGS ARE IN VOLTS.  
 VOLTAGE AMPLITUDE MEASUREMENTS, AS SHOWN, ARE NOT ABSOLUTE. THEY MAY VARY BETWEEN INSTRUMENTS AS WELL AS WITHIN THE INSTRUMENT ITSELF DUE TO NORMAL MANUFACTURING TOLERANCES, AND TRANSISTOR AND VACUUM TUBE CHARACTERISTICS.

SEE PARTS LIST FOR EARLIER VALUES AND S/N CHANGES OF PARTS MARKED WITH BLUE OUTLINE

AE

MRH  
 763  
 TYPE H PREAMP  
 S/N 10,001-UP

PREAMPLIFIER  
 S/N 10001-UP