



WORKING INSTRUCTIONS

THE AUTOMATIC COIL WINDER &
ELECTRICAL EQUIPMENT CO. LTD.
LONDON, S.W.1. ENGLAND.



**THE
"AVO"
WIDE RANGE
SIGNAL GENERATOR**

INSTRUCTIONS FOR USE

THE AUTOMATIC COIL WINDER & ELECTRICAL EQUIPMENT CO. LTD.

WINDER HOUSE, DOUGLAS STREET, LONDON, S.W.1

Telephone: Victoria 3404/9

Grams: Autowinda, Sowest, London.

FOREWORD

For more than a quarter of a century we have been engaged in the design and manufacture of "AVO" Electrical Measuring Instruments. Throughout that time we have consistently pioneered the design of modern multi-range instruments and have kept abreast of and catered for the requirements of the epoch-making developments in the fields of radio and electronics.

The success of our steadfast policy of maintaining high standards of performance in instruments of unexcelled accuracy, and making such instruments available at reasonable cost, is reflected in the great respect and genuine goodwill which "AVO" products enjoy in every part of the world.

It has been gratifying to note the very large number of instances where the satisfaction obtained from the performance of one of our instruments has led to the automatic choice of other instruments from the "AVO" range. This process, having continued over a long period of years, has resulted in virtual standardisation on our products by numerous Public Bodies, The Services, Railway Systems, and Post Office and Telegraph Undertakings throughout the world.

Our designers have thereby been encouraged to ensure that new instruments or accessories for inclusion in the "AVO" range fit in with existing "AVO" apparatus and serve to extend the usefulness of instruments already in use. Thus, the user who standardises on "AVO" products will seldom find himself short of essential measuring equipment, for, by means of suitable accessories, his existing equipment can often be adapted to meet unusual demands.

It is with pleasure that we acknowledge that the unique position attained by "AVO" is due in no small measure to the co-operation of so many users who stimulate our Research and Development staffs from time to time with suggestions, criticisms, and even requests for the production of entirely new instruments or accessories. It is our desire to encourage and preserve this relationship between those who use "AVO" Instruments and those who are responsible for their design and manufacture, and correspondence is therefore welcomed, whilst suggestions will receive prompt and sympathetic consideration.

Whilst every care has been taken in the compilation of this Publication, The Automatic Coil Winder and Electrical Equipment Co. Ltd. cannot accept any liability respecting errors in the text.

CONTENTS

INTRODUCTION	5
CIRCUIT AND GENERAL CONSTRUCTION	7
THE CONTROLS	9
FREQUENCY RANGE	10
ACCURACY AND DISCRIMINATION	11
RADIO FREQUENCY SIGNAL AMPLITUDE	11
LEAKAGE AND RADIATION	11
HARMONIC CONTENT	11
MODULATION	12
FREQUENCY STABILITY	12
LOW FREQUENCY TEST SIGNAL	12
DUMMY AERIAL	12
MAINS SUPPLY	13
REPLACEMENT OF VALVES AND FUSE	13
BATTERY DRIVEN MODEL	14
REPLACEMENT OF VALVES, FUSE AND BATTERIES	14
CIRCUIT DIAGRAM OF MAINS DRIVEN MODEL	17
CIRCUIT DIAGRAM OF BATTERY DRIVEN MODEL	18

COPYRIGHT

No information or diagrams in whole or in part may be copied or reproduced without the prior permission in writing of The Automatic Coil Winder & Electrical Equipment Co. Ltd.



THE "AVO" WIDE RANGE SIGNAL GENERATOR

THE



WIDE RANGE SIGNAL GENERATOR

INSTRUCTIONS FOR USE

INTRODUCTION

The increasing complexity and sensitivity of the modern radio receiver and the widespread use of television receivers have revealed the limitations of the ordinary modulated test oscillator as a servicing tool. Whilst such instruments, of which the "AVO" All Wave Oscillator was an outstanding example, have fulfilled adequately the serviceman's needs for many years, it cannot be denied that something more ambitious is required for dealing with the wide frequency range and extreme sensitivity of the modern communication receiver or the accurately tuned and very high frequency circuits encountered in television.

The main disadvantages of the service oscillator are to be found in the inadequate performance of the attenuator and its inability to provide a minimum signal approaching zero for sets with better than $50\mu\text{V}$ sensitivity. Owing to attenuator leakage and direct radiation, particularly at high frequencies, it is seldom possible to work such sets below their A.V.C. delay level.

To cover such stringent specifications really demands an instrument of the laboratory STANDARD SIGNAL GENERATOR class, the frequency range of which will cover the ordinary broadcast bands, and bearing in mind future television developments, should extend also to well above 60 Mc/s. As such a standard instrument would be well outside the price range of all but the largest laboratories, THE AUTOMATIC COIL WINDER AND ELECTRICAL EQUIPMENT CO. LTD. set themselves the task of developing, at a price within the scope of the ordinary service engineer, a generator which would cover this enormous frequency range, which would provide all the essential requirements of a standard signal generator, and which would, at the same time, be as simple to operate as the ordinary service oscillator.

The result of a long period of development work is the "AVO" Signal Generator, the essential details of which follow.

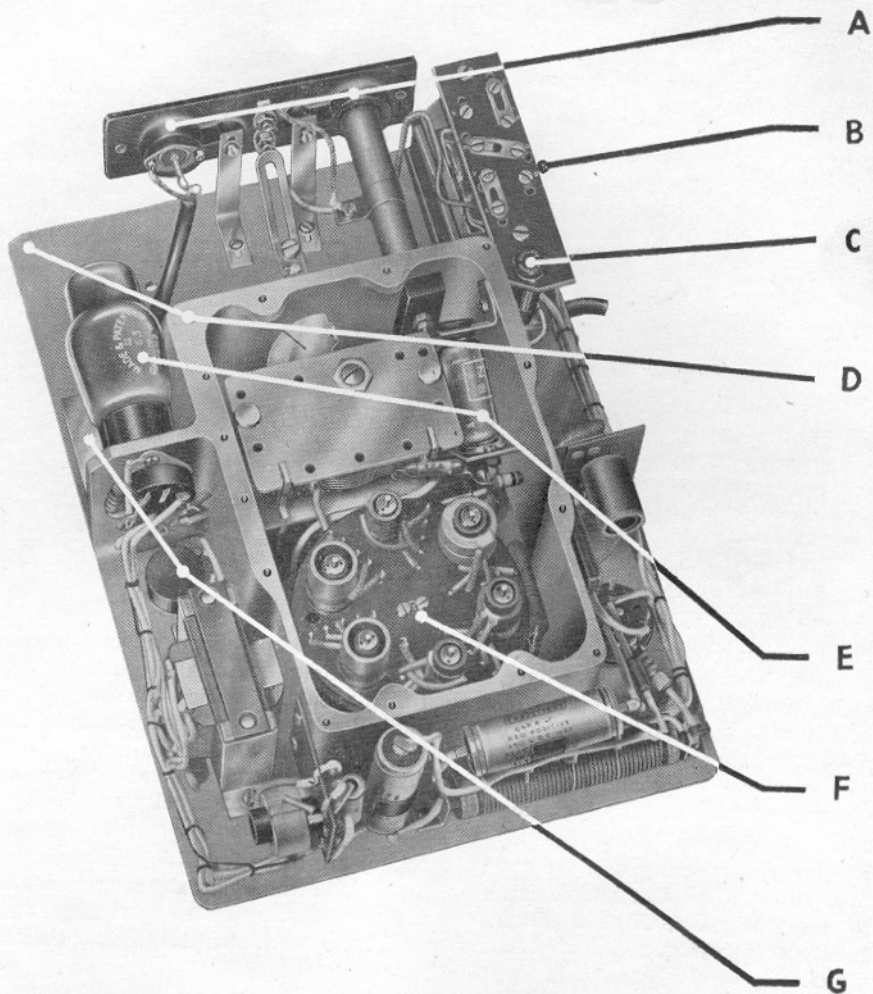

- A.—**OUTPUT.** One coaxial socket for attenuated output. One force output socket located inside R.F. compartment.
- B.—**MAINS TRANSFORMER.** Coded tagboard for inputs of 100-130V and 200-260 V., A.C. 50-60 c/s.
- C.—**FUSE.** This is easily accessible when replacement is necessary.
- D.—**CAST ALUMINIUM H.F. COMPARTMENT & CHASSIS.** Note large number of fixing holes for H.F. compartment cover, ensuring good screening by virtue of excellent electrical bonding.

- E.—**VALVES.** Standard types run at a rating which ensures long life.
- F.—**TURRET COIL SWITCHING.** Standard "AVO" Practice.
- G.—**ATTENUATOR SYSTEM.** Employs specially developed close tolerance midget high stability carbon resistors, low reactance rotary potentiometer modified for R.F. operation with carefully designed screening.

CIRCUIT AND GENERAL CONSTRUCTION

A high slope button R.F. pentode oscillator is used in a modified Colpitts circuit delivering approximately 0.5 V. R.F. signal into an attenuator system having a characteristic impedance of 80 ohms. This variable output is available at a screened coaxial socket into which fits the special screened output lead and dummy aerial. The 0.5 V. signal is also available at a separate screened socket as a fixed force output, the source impedance in this case being increased to 400 ohms to eliminate any possibility of interaction of the load on to the oscillator circuit. Before entering the attenuator system proper the half-volt signal is divided by ten and the 50 mV signal so obtained is fed to a variable attenuator of low impedance and reactance, the control knob of which is calibrated in μV . The output from the variable attenuator is further sub-divided in four steps having attenuation ratios of 1, .1, .01 and .001, by a step attenuator constructed of small non-reactive resistance elements. By the use of a massive casting to house the oscillator, and by careful attention to screening and earthing of the attenuator elements outside the oscillator housing, unwanted signals in the attenuator system are eliminated. This feature, together with the provision of suitable screens in between the separate sections of the attenuator to eliminate capacitive leakage, have resulted in the unwanted output signal, with all the attenuator controls set at minimum, being of negligible proportions even at the very high frequencies. For similar reasons the sub-division accuracy is well maintained over the frequency range. Thus, providing that the input to the variable attenuator is kept reasonably constant, the attenuator output can be calibrated in μV and mV, this calibration holding good within reasonable limits at all frequencies.

Simple compensating circuits are employed which vary the tuned circuit damping and the mutual conductance of the oscillator valve in conformity with the amplitude, and to some extent the frequency of the signal voltage developed, with the result that the high level signal to the attenuator is held virtually constant and has a very low harmonic content. The above requirement for a reliable calibrated output is thus achieved.

The radio frequency signal is modulated at a nominal frequency of 400 c/s and a depth of 30 per cent., series anode modulation being employed. A separate low frequency oscillator valve with heavy negative feed back ensures a modulation wave form of high purity whilst the use of a screen grid radio frequency oscillator valve tends to keep frequency modulation at a minimum. Switching is provided to enable the output signal to be obtained either modulated, unmodulated or modulated by an external source, whilst the L.F. modulation signal is available via a separate L.F. attenuator at two specially provided sockets.

The power supply for the instrument is self-contained and derived from 50-cycle A.C. mains from 100 to 260 volts. Adequate smoothing is provided, and complete R.F. filtering eliminates R.F. leakage into the mains which would tend to spoil the low minimum signal.

The dummy aerial is so designed as to be suitable for use over the full frequency band of the instrument, and is housed in a very light and compact screening box at the end of the main output cable. A terminal is provided on the assembly so that the dummy aerial can be by-passed and the signal obtained directly from the cable. A separate plug is provided for bringing out the force output signal, the contact for which is made well inside the instrument by a long tubular screening socket to eliminate any internal or external leakage from this source.

The whole instrument is housed in an attractively finished metal screening box which

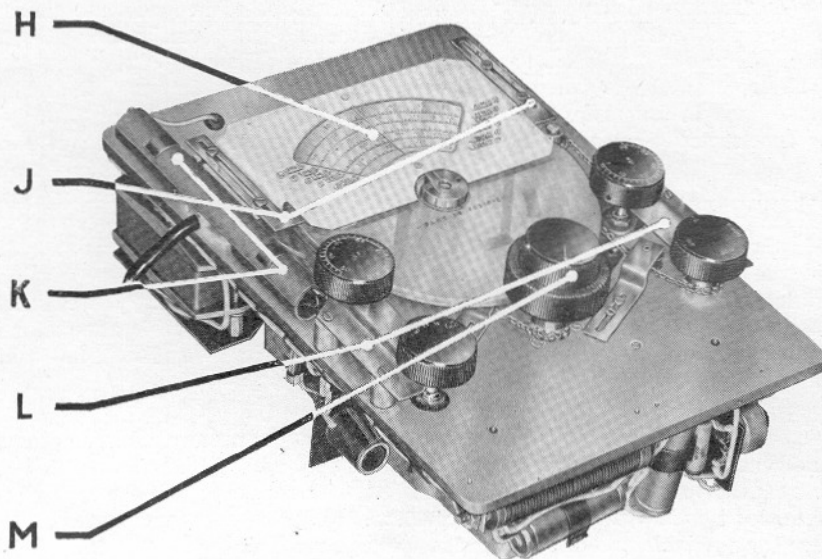

H.—ILLUMINATED SPOT RANGE SELECTOR. Gives a rapid identification of operational frequency band and intensified lighting around the precise frequency of operation. Well designed layout of frequency scales coupled with a fine hair line giving close discrimination, particularly on high frequencies.

J.—STOPS. Separate stops to prevent turning of dial with respect to condenser.

K.—MAIN FILTER SYSTEM. This is screened from main electrical assembly.

L.—BUSHING PLATES. These provide additional rigidity for rotary controls.

M.—SLOW MOTION DRIVE. This is substantially free from backlash.

still further serves to reduce stray radiation, whilst the controls are pleasingly grouped on the face of the instrument. A feature of the controls is a specially designed masking device coupled to the band change switch, which serves to accentuate, by means of internal lighting, only the effective portion of the frequency band in use, immediately adjacent to the cursor line. Positive identification of the frequency under consideration is thus assured and possible ambiguity due to the use of a fully calibrated scale of many bands is eliminated.

THE CONTROLS

Six controls are provided, their respective functions being as follows: The two calibrated knobs on the right of the instrument panel serve to indicate the value of the attenuated signal. The variable attenuator control is calibrated in μV from 1 to 50, and the step attenuator control has four positions marked $\times 1$, $\times 10$, $\times 100$ and $\times 1,000$. The actual value of the output signal is obtained by multiplying together the settings of these two controls.

The two controls to the left of the instrument are the modulation switch, and the combined on/off switch and variable L.F. attenuator. The former is marked in four positions, indicating the nature of the output signal. With the switch set to position "R.F." a pure R.F. signal is obtained, the frequency and amplitude of which depend on the setting of the band switch, the calibrated frequency dial and the attenuators. At the next setting of this switch marked "EXT" the signal may be modulated from an external low frequency source applied via the L.F. sockets. Compensation is introduced both at this setting and at the R.F. setting of the instrument to keep the high tension load stable when the modulator valve is not functioning, thus avoiding undue variations in R.F. output. At the setting "INT," the R.F. signal is internally modulated by the 400 cycle modulation signal, whilst at the remaining switch position "L.F.," the 400 cycle L.F. modulating signal is available at the output sockets for L.F. testing purposes, the R.F. oscillator being switched off. The amplitude of this signal is varied by the L.F. attenuator. The latter is arbitrarily marked on a linear scale 0 to 50, this marking being purely for the convenience of the operator, enabling him to take note of a L.F. signal strength at which any desired conditions are attained. In actual practice the control law of this attenuator is logarithmic in character, so that when testing sensitive L.F. amplifiers, small graduations of L.F. signal will be easily available. The position on this control marked "OFF" indicates the setting at the extreme anti-clockwise rotation at which the mains on/off switch of the instrument is brought into operation to switch the generator off.

Immediately below the dial escutcheon are two concentric control knobs, the upper and smaller one marked with an arrow operates the turret band change switch, the arrow indicating on the surrounding printed plate the number of the frequency band to which the oscillator is switched. This band numbering corresponds to the numbers and frequency limits printed on the white dial bezel, the markings thereon being collinear with the appropriate printed frequency scale on the main dial. This band change knob also automatically operates the selective band indicating lighting system already mentioned.

The lower of the two concentric knobs which is of larger diameter and has a knurled edge operates the main frequency dial via a smooth slow motion control which although light in operation is virtually devoid of backlash.

FREQUENCY RANGE

The complete frequency range of the instrument is 50 kc/s to 80 Mc/s covered in six bands with a total calibrated scale length of 45 inches, viz.:

Band 1. 50 kc/s to 150 kc/s.

Calibrated sub-divisions are marked at intervals of 1 kc/s from 50 to 80 kc/s and, thereafter, at intervals of 2 kc/s to 150 kc/s.

This band covers the very long wave shipping broadcasts, etc., and low intermediate frequencies.

Band 2. 150 kc/s to 500 kc/s.

Calibrated sub-divisions at intervals of 2 kc/s from 150 to 200 kc/s, at 5 Kc/s up to 250 kc/s and at 10 kc/s to 500 kc/s.

This band encompasses the long wave broadcasts and the generally used intermediate frequencies for broadcast receivers.

Band 3. 500 kc/s to 1,500 kc/s.

Sub-divisions are calibrated at intervals of 10 kc/s from 500 to 800 kc/s and at 20 kc/s intervals up to 1,500 kc/s.

The frequencies covered on this band constitute the normal broadcast medium wave band.

Band 4. 1.5 Mc/s (1,500 kc/s) to 5.5 Mc/s.

Calibrated sub-divisions at .02 Mc/s (20 kc/s) up to 2 Mc/s, at .05 Mc/s up to 3 Mc/s, and at 0.1 Mc/s intervals to 5.5 Mc/s.

This band covers certain intermediate frequencies used in America, some broadcast frequencies, shipping and aircraft signals.

Band 5. 5.5 Mc/s to 20 Mc/s.

Calibrated sub-divisions at 0.1 Mc/s up to 9 Mc/s from 9 to 15 Mc/s the sub-divisions are at .2 Mc/s, intervals and from 15 Mc/s to 20 Mc/s sub-divisions are at every 0.5 Mc/s.

Television I.F. The main broadcast short wave and amateur signals are covered on this range.

Band 6. 20 Mc/s to 80 Mc/s.

Sub-divisions occur at 0.2 Mc/s intervals up to 30 Mc/s, at 0.5 Mc/s intervals up to 45 Mc/s and thereafter at 1 Mc/s interval.

This very useful frequency band encompasses the shorter wave broadcast signals, the standard and proposed television signals and at the extreme upper frequency end, police and certain inter-communication broadcast frequencies.

ACCURACY AND DISCRIMINATION

The accuracy of frequency calibration of the instrument is within 1 per cent. of the frequency markings, calibrations in general occurring at every 2 per cent. of frequency. Dial settings can thus be made with care to better than 0.2 per cent. of the frequency, whilst the mechanical accuracy of the instrument is such that even closer discrimination intervals can be obtained providing that some external beat method of accurately determining the exact frequency difference is utilised. It will be noted that the maximum calibrated scale length is provided on the highest frequency band for ease in dealing with the fairly stringent frequency requirements of television receivers.

RADIO FREQUENCY SIGNAL AMPLITUDE

The high level signal into the attenuator is held to better than plus/minus 2 db about a mean value of 0.5 volts RMS on all the frequencies covered by Bands 1 to 5. On the very highest frequency band a somewhat lower overall level is obtained, but even on this band it does not fall below the limits of -1.5 to 6 db about a level of 0.5 volts.

The careful design of the dual attenuator system is such that a very reasonable accuracy of sub-divisions is maintained around the above signal limits and, in general, overall additional errors due to the attenuator settings do not amount to more than some 2 or 3 db depending on the setting of the attenuator. For all normal purposes, therefore, the signal calibration of the attenuators can be relied on for receiver and other sensitivity measurements within normally practical limits.

LEAKAGE AND RADIATION

The minimum signal obtainable at the dummy aerial output terminals with all attenuator controls set at minimum is such as to be negligible at all frequencies for normal test purposes. Absolute values of the minimum signal are of the order of $1 \mu\text{V}$ up to frequencies of about 10 Mc/s, better than $2 \mu\text{V}$ up to 30 Mc/s and better than $3 \mu\text{V}$ up to 80 Mc/s. The screening and mains filtering are such that direct radiation from the instrument at a distance of 1 metre into an aerial 1 metre long is better than $1 \mu\text{V}$ even at the very high frequencies. In actual practice even with the most sensitive receiver it is almost impossible to determine any directly radiated signal.

HARMONIC CONTENT

Except at the high frequency end of Band 1 where the L/C ratio of the oscillator tuned circuit becomes extremely high, the harmonic content of the radio frequency signal is only of the order of 1 per cent. At frequencies of the order of 100 to 150 kc/s on Band 1 this harmonic content may rise to about 5 per cent.

MODULATION

Internal modulation is of good wave form at a frequency of 400 c/s plus or minus 5 per cent. to a depth of approximately 30 per cent.

Provided that a source of L.F. signal is available, such as a beat frequency oscillator, the R.F. signal may be modulated from this external source. The output impedance of this source should be low (say, 600 ohms or less), and under these conditions reasonably distortion-free modulation can be obtained over the range of approximately 250 c/s to 10,000 c/s. For this purpose approximately 50 to 60 volts of L.F. signal are required for modulation of the order of 20 to 30 per cent., and the L.F. attenuator control should be set at its maximum position.

When the frequency range below 240 c/s is considered, trouble is encountered due to the resonant frequency of the unloaded internal modulation transformer, in which resonance occurs round about 200 c/s. The effect of this resonance is to increase sharply the modulation percentage. The modulation wave form, however, still remains quite good. The percentage modulation may be decreased at frequencies around 200 c/s by turning the L.F. attenuator control from its maximum position to a setting about 40 (maximum being represented by 50), and providing that this precaution is introduced for frequencies, say, between 150 and 250 c/s, then the external modulation frequency range may be extended down to some 100 c/s at which point virtual cut off occurs.

FREQUENCY STABILITY

The careful design which has been applied to the R.F. oscillatory circuit has resulted in a remarkable degree of frequency stability and to give some idea of the stability attainable figures taken on a representative sample instrument are given below:—

1. At an initial frequency setting of 40 Mc/s the instrument when switched on from cold showed a thermal drift of approximately 20 kc/s during the first two or three minutes and thereafter, tested at regular intervals for the period of an hour, showed no noticeable deviation from the fundamental setting.
2. A ± 10 per cent. variation of mains voltage gave rise to a frequency variation of approximately 100 c/s at 75 kc/s, 100 c/s at 600 kc/s, 2 kc/s at 6 Mc/s, and 3 kc/s at 40 Mc/s, the initial dial calibration being carried out at a mains voltage of 225V.

LOW FREQUENCY TEST SIGNAL

The magnitude of the L.F. test signal available at the output sockets is approximately 50 volts at the maximum setting of the attenuator. The output impedance of the attenuator circuit varies between approximately 50,000 ohms to zero as the attenuator control is turned from maximum to minimum.

DUMMY AERIAL

The screened all wave dummy aerial is of a standard design giving an approximately constant impedance characteristic over the full frequency band of the instrument. The average value of this impedance is approximately 400 ohms rising in the normal manner to something

of the order of 1,000 ohms below 1 Mc/s. When using the dummy aerial, to ensure a minimum of stray pick up especially at high frequencies the shortest possible leads should be used to the terminals, particular care being taken with the earthing lead which should make good connection and be of very low resistance.

MAINS SUPPLY

The instrument is suitable for connection to A.C. mains voltages between 100-130 volts 50-60 c/s and 200-260 volts 50-60 c/s. Should it be necessary to alter the mains voltage tapping from the normal 220-240 volt mains for which the instrument is initially adjusted, remove the small inspection plate from the rear of the instrument, thus exposing to view the tap changing board and fuse. The mains voltage connections for different values of voltage are then made as in the table below.

Operating Voltage	Connect H to	Connect Q to	Link
100-110V.	B & D	C & E	—
110-130V.	A & D	C & F	—
200-220V.	B	E	C & D
220-240V.	A	E	C & D
240-260V.	A	F	C & D

REPLACEMENT OF VALVES AND FUSE

Remove four screws in bottom of case and four screws in the output socket escutcheon. Lift off bottom part of instrument case. The modulation valve L63 or 6J5 will at once be visible and can easily be removed and replaced.

The R.F. Oscillator valve 8D3, Z77 or 6AM6 is located inside the cast aluminium box, the lid of which can be removed by the withdrawal of 14 self-tapping screws. It will be noted that the valve is held in position by a rubber grommet mounted in a bracket. This bracket must be removed before the valve is withdrawn from its holder.

It is important that all 14 screws are replaced and tightened after replacing valve to prevent stray R.F. radiation. Whilst carrying out this operation, it is vitally important that the coil turret and associated circuits should not be disturbed.

A 1 amp. Fuse (Belling Lee L1055-1A) or a 500 mA Fuse (Belling-Lee L1055/500 mA) is located beneath the inspection plate upon the rear of the instrument.

BATTERY-DRIVEN MODEL

The specification of both the mains and battery-driven instruments are very similar, the battery version only differing in respect to the mains model as follows:—

- (1) The instrument uses internal batteries as its power source.
- (2) It was decided not to illuminate the frequency dial, for the lamps would have drained the L.T. battery to a far greater extent than the valves themselves. The longest possible life of the L.T. battery has therefore been achieved.
- (3) The frequency coverage of the instrument is 50 Kc/s-70 Mc/s in six bands.

REPLACEMENT OF VALVES, FUSE AND BATTERIES

Remove four screws in bottom of case and four screws in the output socket escutcheon. Lift off bottom part of instrument case. The modulation valve N16 or 3Q5 will at once be visible and can easily be removed and replaced.

The R.F. Oscillator valve N.17 or 3S4 is located inside the cast aluminium box, the lid of which can be removed by the withdrawal of 14 self-tapping screws. It will be noted that the R.F. valve is held in position by a rubber grommet mounted in a bracket. This bracket must be removed before the valve is withdrawn from its holder.

Battery replacements are as follows:—

H.T. Ever Ready type B101 (or equivalent)	67.5V
L.T. „ „ „ 800 („ „)	3V

It is important that all 14 screws should be replaced and tightened after replacing the valve to prevent stray R.F. radiation. Whilst carrying out this operation, it is vitally important that the coil turret and associated circuits should not be disturbed.

A 60mA fuse (Belling-Lee L1055-60mA) is located upon the side of the cast R.F. box.

IMPORTANT NOTE

Special precautions must be taken when servicing an A.C./D.C. set. Ensure that the mains plug connected to the set under test is inserted in such a manner that the chassis is earthy. To check, a meter set at a sufficiently high range should be connected between the chassis and earth. If the mains voltage is shown upon the meter, reverse the supply to the set.

If it is desired to inject an R.F. signal at a point of high potential, the dummy aerial terminal should always be used. Ideally a small high voltage working condenser should be inserted in series with the R.F. output.

NOTES





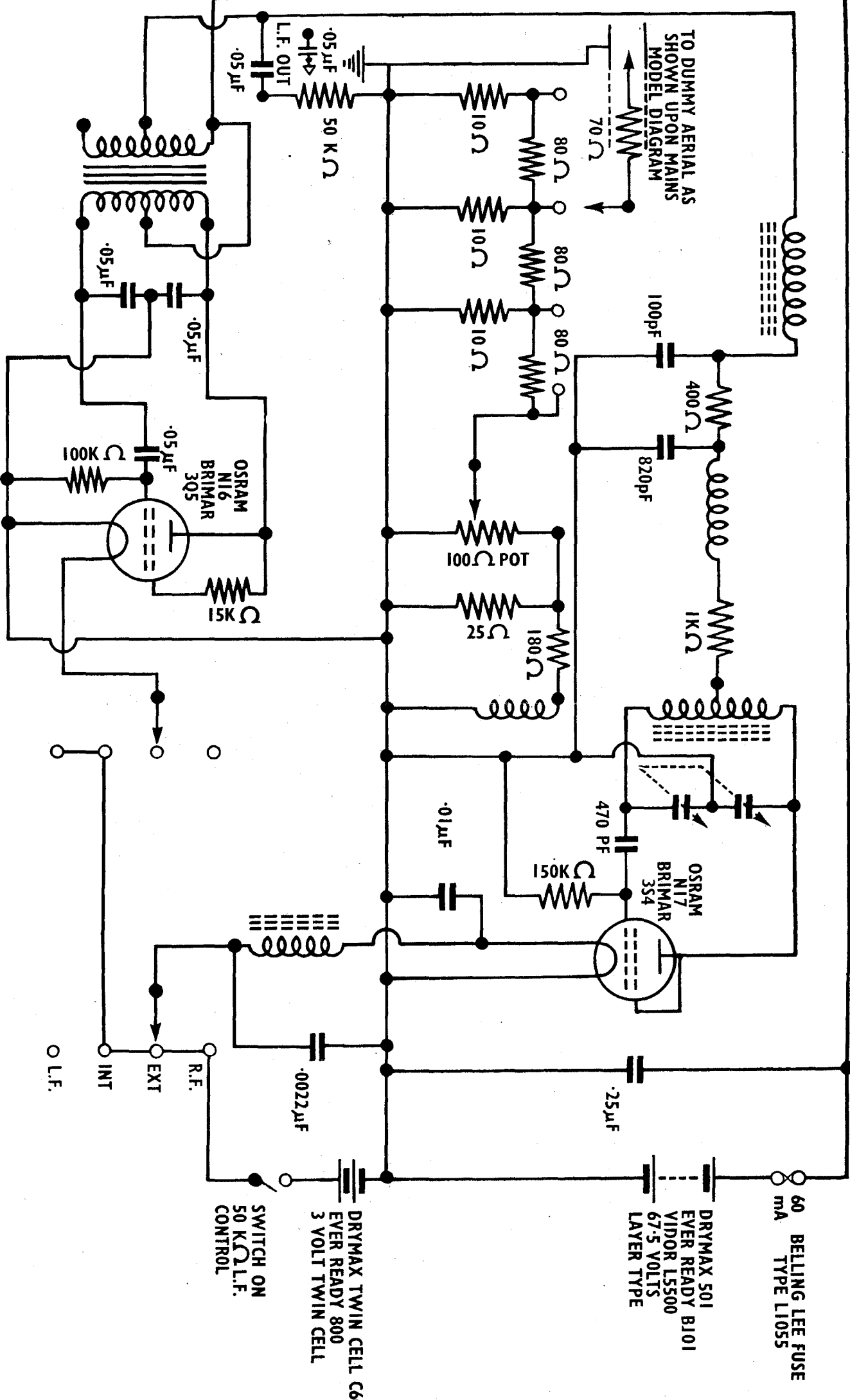

THE "AVO" WIDE-RANGE SIGNAL GENERATOR - BATTERY MODEL

CIRCUIT DIAGRAM

60 mA BELLING LEE FUSE
TYPE LI055

DRYMAX 501
EVER READY B101
VIDOR L5500
67.5 VOLTS
LAYER TYPE

DRYMAX TWIN CELL C60
EVER READY 800
3 VOLT TWIN CELL

SWITCH ON
50 KΩ L.F.
CONTROL

R.F.
EXT
INT
L.F.