

Arboga Elektronikhistoriska Förening
www.aef.se

9528

Avd. 1655

DIGITAB™ TA 305 SERIES VOLTAGE AND CURRENT DIGITAL PANEL METERS

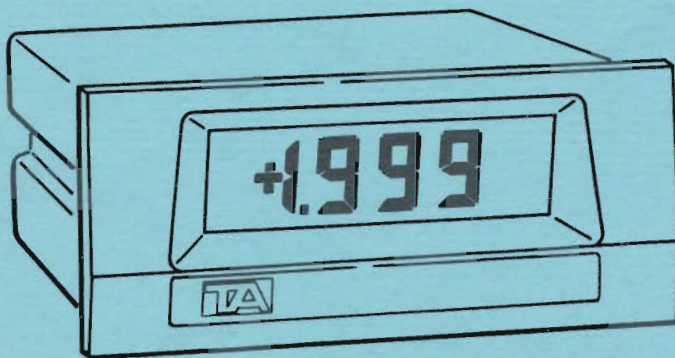

AKTIV  ELEKTRONIK AB

BOX 3365
S-162 03 VÄLLINGBY
TEL 08-739 00 45

TEKELEC, INC. 

INTRODUCTION

Your TEKELEC[™] TA 305 Series Digital Panel Meter was produced utilizing the latest L.S.I. techniques, Field Effect Liquid Crystal Display and Poly-Tek (Patent Pending) conversion techniques combined with high quality components. Stringent quality control methods assure reliability, stability, and accuracy previously found only in high-cost instrumentation.

Through the use of the most advanced engineering and materials technology, plain old-fashioned attention to detail, and a great pride in craftsmanship, we know your instrument will have a long trouble-free life and will maintain the expected accuracy. As an example, your instrument has been carefully inspected during assembly, "burned in" for a minimum of 200 hours and calibrated using instruments traceable to the National Bureau of Standards.

This instruction manual is provided to make the use and maintenance of this instrument as easy as possible, and a few minutes of reading prior to use is highly recommended. If there are any questions regarding this instrument, or special requirements relative to your application and use, feel free to call any of our offices.

NOTICE

This document contains proprietary information of Tekelec, Inc. Any reproduction, use, and/or disclosure of this document, or any portions thereof, is expressly prohibited without the prior written consent of Tekelec, Inc.

TABLE OF CONTENTS

<u>Section/Paragraph</u>		<u>Page</u>
SECTION I	GENERAL INFORMATION.....	1-1
	1-1. Scope.....	1-1
	1-3. Basic Panel Meter.....	1-1
	1-10. Specifications.....	1-2
	1-12. Options.....	1-2
SECTION II	INSTALLATION.....	2-1
	2-1. General.....	2-1
	2-3. Front Mounting.....	2-1
	2-5. Rear Mounting.....	2-2
	2-7. Connector Data.....	2-2
SECTION III	THEORY OF OPERATION.....	3-1
	3-1. General.....	3-1
	3-3. Functional Description.....	3-1
	3-12. Diagrams.....	3-3
SECTION IV	MAINTENANCE.....	4-1
	4-1. General.....	4-1
	4-3. Periodic Maintenance.....	4-1
	4-8. Calibration.....	4-2
	4-15. Servicing Instructions.....	4-4



Figure 1-1. TA 305 Series Digital Panel Meters

SECTION I GENERAL INFORMATION

1-1. SCOPE.

1-2. This instruction manual contains the specifications and model options, installation data, theory of operation, maintenance instructions and parts location information for the Digitab™ TA 305 Series Digital Panel Meters. This series of panel meters provides a 3-1/2 digit display and is available in five DC voltage ranges (TA 305-02 through TA 305-06) and eight DC current ranges (TA 305-12 through TA 305-19). In addition to the basic instrument, seventeen options are available to satisfy a multitude of applications. The configuration of your specific instrument may be determined by decoding the data plate located on the top of the unit and comparing the option stated to those listed in Table 1-5, List of Options.

1-3. BASIC PANEL METER.

1-4. All basic TA 305 Series Digital Panel Meters are of a standard size and share commonality of circuit design. All models use the same rugged all-metal case for improved electrical shielding and heat transfer, and for simple through panel mounting and easy interchangeability. The standard instrument is provided with a snap-on sculptured bezel which is easily removed for access to zero and span adjustment controls. Included in the standard instrument is a non-isolated serial BCD output which includes data, polarity, and overflow (a fully isolated BCD output is optional - refer to paragraph 1-12), and a hold-read function for pulsed or single-read operation. Digital linearization control is provided as input and output signals for external digital control of scale factor and curve fitting. A selectable decimal point (four locations) which is activated at the input connector. Automatic bipolar operation with polarity indicator is standard. An overvoltage indication is provided by the flashing of all display segments. The input/output plug is a standard printed circuit board type utilizing a Cinch type 251-15-30-160 or Tekelec P/N 211002802 mating connector (not supplied with instrument). An optional terminal barrier strip is available, if desired (refer to paragraph 1-12). All panel meters feature the Poly-Tek™ analog-to-digital conversion system, "field-effect" liquid crystal display, custom MOS integrated circuits, plug-in range modules, and an internal transformer power supply.

1-5. ANALOG-TO-DIGITAL CONVERSION. The Poly-Tek™ A-D Converter employs a completely new method of conversion which operates on a concept that provides high noise rejection without the need for an input filter. Total response time is 10 milliseconds and normal mode noise rejection is 40 DB at 60 Hz (60 DB with

optional input filter). A reading rate of 2 complete readings per second (or up to 12 readings per second in accordance with an external read command) and a measurement period of 33.3 milliseconds is standard. Slower reading rates are optionally available (refer to paragraph 1-12). By means of custom MOS and bipolar integrated circuits, this A-D converter combines exceptional accuracy, stability, high noise rejection, and fast response.

1-6. LIQUID CRYSTAL DISPLAY. The "Field Effect" liquid crystal transmissive display retains all of the inherent advantages of earlier displays but with vastly improved appearance and readability. Characteristics of the display include low voltage operation, microwatt power consumption, large (0.5 inch) high-contrast white-on-black characters and long term reliability. Optional reflective or colored displays are available (refer to paragraph 1-12).

1-7. INTEGRATED CIRCUITS. A custom MOS digital integrated circuit and a matching custom designed analog integrated circuit comprise 98 percent of the required circuit elements thereby providing ultra-reliability at low cost.

1-8. RANGE MODULES. The range module, a low cost plug-in unit, determines the application (voltage or current) and the meter full-scale range. There are 5 full-scale voltage ranges from 200 millivolts to 1000 volts DC, and 8 full-scale current ranges from 200 nanoamperes to 2 amperes, which provide great flexibility of application. These low cost range modules are completely interchangeable in the TA 305 Series Digital Panel Meters and may be purchased separately to extend the range and application of the basic instrument.

1-9. POWER SUPPLY. The standard power supply incorporated into the instrument is rated at 117 VAC ($\pm 10\%$), 60 Hz, and provides both line transient suppression and regulation of line voltage fluctuations. The total power consumption of the instrument is designed to utilize 1.5 watts (nominal) for cool reliable operations and long life. Optional power supplies are available (refer to paragraph 1-12).

1-10. SPECIFICATIONS.

1-11. The general specifications of the TA 305 Series Digital Panel Meter are contained in Table 1-1. Tables 1-2 through 1-4 list the characteristics of the DC voltage meters and DC current meters.

1-12. OPTIONS.

1-13. All models of the TA 305 Series Digital Panel Meters have been designed to accommodate an impressive range of optional features and capabilities. The list of options is provided in Table 1-5. Options A5, A8, A11, A12, and A18 are regularly manufactured and stocked. Options A1, A2, A3, A4, A6, A7, A10 through A16, and A17 are manufactured on special order basis. Options A12, A13, A15, and A16 are custom manufactured and desired requirements must be specified.

Table 1-1. General Specifications

Analog Input	
Configuration.....	Two wire floating input
Polarity.....	Bipolar, automatic
Display	
Type.....	Field effect transmissive liquid crystal, single plane, non-blinking, 7-segment. (For reflective display, see Optional A11)
Digits.....	3-1/2 (± 1999) digits, 0.5" high
Decimal Point.....	4 selectable locations
Color.....	White on black background. (For colored numerals, see Option A12)
Overflow Indication.....	All display segments flash
A-D Conversion	
Type.....	Poly-Tek tm conversion system
Measurement Period.....	33.3 milliseconds (see Option A6)
Reading Rate.....	10 readings/second or by external read command. (For slower rates, see Option A13)
Noise Rejection	
Common Mode Rejection.....	Greater than 80 DB, DC to 60 Hz
Common Mode Voltage.....	220 V RMS relative to earth ground (or digital low with Option A8)
Normal Mode Rejection.....	40 DB at line frequency (60 DB with input filter Option A7)
Response Time.....	10 milliseconds to 0.1% for full scale step input
Calibration.....	Zero and span screwdriver adjustments accessible from front by removing snap-on bezel

Table 1-1. General Specifications (Continued)

Outputs	
BCD Data.....	Serial, non-isolated. Includes data, polarity, and overflow. (For isolated parallel outputs, see Option A8)
Clock.....	600 kHz, non-isolated (500 kHz with Option A6)
Controls	
Decimal Point.....	Selectable at input connector
External Hold-Read.....	Hold previous reading until new reading is initiated. Single reading may be triggered
Environmental	
Operating.....	0°C to +55°C, 80% relative humidity
Storage.....	-40°C to +85°C
Power.....	117 VAC \pm 10%, 60 Hz, 1.5 watts nominal. With reflective display (Option A11) power reduced to 0.95 watts nominal. (See Options A1, A2, A3, A4, and A5)
Mechanical	
Size.....	3.880" W (98.55 MM) x 1.670" H (42.41 MM) x 4.280" D (108.71 MM) behind panel, including connector protrusion
Panel Cutout.....	3.890" W x 1.682" H \pm 0.010" (98.80 MM W x 42.72 MM H \pm 0.25 MM)
Case Material.....	All metal case with high-impact plastic decorative bezel
Output Connector	
Standard.....	Printed circuit board
Option A10.....	Barrier terminal strip

Table 1-1. General Specifications (Continued)

Mating Connectors (Not supplied)	
Standard.....	Cinch type 251-15-30-160 or Tekelec P/N 211002802
For Parallel BCD..... (Option A8)	Cinch type 251-18-30-160 or Tekelec P/N 211002801

Table 1-2. DC Voltage Meters Characteristics

Model	TA 305-02	TA 305-03	TA 305-04	TA 305-05	TA 305-06
Full Scale Input	±199.9 MV	±1.99 V	±19.99 V	±199.9 V	±1000 V
Resolution	100 UV	1 MV	10 MV	100 MV	1 V
Input Impedance	100 meg Ω	100 meg Ω	10 meg Ω		
Maximum Input Bias Current @ 23°C	±300 PA		±30 PA	±3 PA	±0.3 PA
Maximum Input Bias Current Temperature Coefficient	±150 PA/°C		±15 PA/°C	±1.5 PA/°C	±0.15 PA/°C
Maximum Safe Input	250 VDC or RMS		1000 VDC or peak AC		
Accuracy @ 23°C ±1°C For 7 Hours	±0.05% R. ±0.05% F.S.				±0.1% R. ±0.05% F.S.
Accuracy @ 15°C to 35°C For 1 Year Without Adj.	±0.15% R. ±0.1% F.S.		±0.2% R. ±0.1% F.S.		±0.3% R. ±0.2% F.S.

To all quoted accuracy specifications, add the digitizing uncertainty of ±0.5 count.

R. = Reading F.S. = Full Scale

Specifications may be changed without notice.

Table 1-5. List of Options (Continued)

Option	Description
A5	+5 VDC Power - The entire meter operates from a single +5 VDC power supply. Power consumption is less than 1.5 watts including display illumination. For use in 60 Hz primary power areas, unless Option A6 is specified.
A6	40 Milliseconds Measurement Time - For maximum NMR, this option changes the converter measurement time to 40 milliseconds for operation in 50 Hz primary power areas. Supplied with Options A1, A2, A3, and A4 unless otherwise specified.
A7	Input Filter - For operation in extremely noisy environments, a single pole filter provides an additional 20 DB noise rejection at line frequency (50-60 Hz) for a total normal mode noise rejection of 60 DB.
A8	Isolated Parallel BCD Output - Includes 2-1/2 or 3-1/2 digits of BCD data, plus overflow, polarity and print command. Outputs are positive true, TTL compatible, and capable of driving one standard 7400 series load. Outputs are fully isolated from input low and power line by 100 megohms minimum. Maximum common mode voltage is 220 V RMS.
A9	Behind-The-Panel Mounting - For behind-the-panel mounting on screws or studs. (Decorative bezel not supplied with this option.)
A10	Screw Terminal Input/Output Connections. For industrial applications, a screw terminal barrier strip replaces the P/C connector.
A11	Reflective Display - For applications requiring exceptionally low power consumption, a reflective display featuring black numerals on a light grey background is provided. Total meter power is reduced to 0.95 watts.
A12	Colored Display Characters - For applications where color coded displays are desired, red, green, orange, or blue display filters can be provided. Specify color.
A13	Reduced Reading Rates - Reading rates as low as 1 reading per 10 seconds can be provided. Tolerance is $\pm 10\%$. Specify rate.

Table 1-5. List of Options (Continued)

Options	Description
A15	Reduced Input Bias Current - For applications with a high or a changing source impedance, or operation under widely varying temperatures with source impedances over 10 K Ohms. This option provides input bias current of less than 50 pico amps at 23°C and a temperature coefficient of 2.5 pico amps/°C. Specify requirements.
A16	Higher Performance Input Amplifier - The Digitab™ TA 305 series meters are designed to accommodate a wide range of available input amplifiers to satisfy special applications. Offset voltage temperature coefficients as low as 1 UV/°C and input bias currents as low as 1 pico amp with a temperature coefficient of 0.05 pico amp/°C can be supplied. Specify requirements.
A17	+ or - Sign Blanked - Displays absolute magnitude of input without sign.
A18	AC Line Cord With Connector and 2 Foot Signal Leads - Permits operation of the unit without wiring an external connector.

SECTION II INSTALLATION

2-1. GENERAL.

2-2. This section contains general installation information and input/output connector data for the standard instrument and for Options A8 and A10.

2-3. FRONT MOUNTING.

2-4. The standard instrument is provided with a readily removable front bezel behind which is located the mounting flange and securing hardware. Figure 2-1 illustrates the outline dimensions of the instrument and the size of the panel cutout required. Install the instrument as follows:

- a. Check data plate of instrument and compare options to those stated in Table 1-5 in order to determine that line voltage, frequency, and input voltage or current characteristics are compatible with installation.
- b. Insure wiring to instrument mating connector(s) is made in accordance with paragraph 2-7.
- c. Snap bezel from instrument using indentions on underside.
- d. Turn both pawl screws counterclockwise until distance between pawl and the rear surface of the instrument mounting flange is approximately $5/32$ inch.
- e. Insert instrument into panel cutout from the front.
- f. Pressing instrument firmly against the panel, tighten pawl screws until snug. Do not overtighten or damage to pawl screws may result.
- g. From rear of panel check that both pawls are positioned correctly behind panel. If required, loosen pawl screw, reposition, and tighten until snug.
- h. Snap instrument bezel into place.
- i. Perform the following connection as applicable:

(1) Mount previously prepared mating connector(s) to instrument using self-tapping screws through connector. Use tubular spacers between connector body and rear of instrument.

NOTE

Connector should be mounted so that pin 1 is on top and pin A is on the bottom (located at the left end of the connector strip as viewed from the rear of the meter).

(2) If Option A10 is installed, connect wiring prepared in step b to barrier terminal strip.

j. Instrument is now ready for operation.

2-5. REAR MOUNTING.

2-6. With Option A9, no front bezel is provided. The instrument is secured to the rear of the mounting panel by means of through-panel screws and nuts or mounting studs. Figure 2-2 illustrates the panel cutout dimensions and mounting holes for rear mounting. Installation instructions steps a, b, i, and j of paragraph 2-4 are applicable to rear mounting.

2-7. CONNECTOR DATA.

2-8. Information relative to the connector pin assignments and description relative to pin functions is contained in the following paragraphs.

2-9. PIN ASSIGNMENTS. The input/output signal pins vary with the options installed on the basic instrument. The pin configuration of the standard analog connector is listed in Table 2-1.

NOTE

Note that for normal operation (no external linearization control) pins H and L must be jumpered together at the external connector.

When Option A8 is installed, the pin configuration for the digital card is listed in Table 2-2. The use of Option A8 requires that external jumpers be made between the connector mating with the analog card and the connector mating with the digital card. These external jumpers provide power and the serial BCD data to the digital card. The external jumpers vary according to whether an AC or DC power supply is used in the basic instrument. Tables 2-3 and 2-4 list the pin data for an AC or DC supply, respectively. If Option A10 (Barrier Terminal Strip Connector) is incorporated in the basic instrument, the terminal wiring data listed in Table 2-5 is applicable. If both Options A8 and A10 are incorporated, required wiring between the analog and digital cards is made internally to the instrument. The lower barrier terminal strip is the analog strip and the

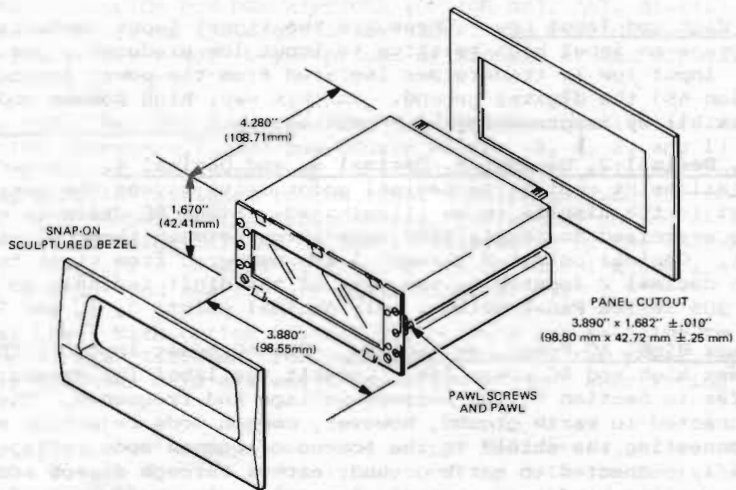

Figure 2-1. Front Mounting Installation

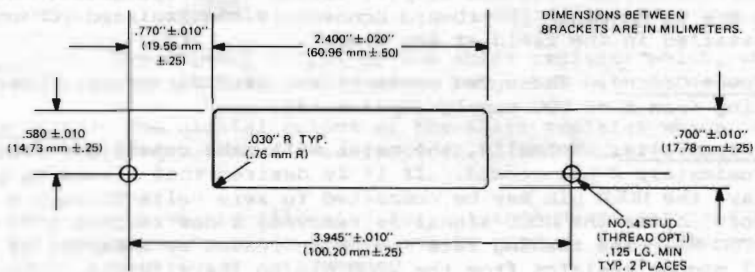

Figure 2-2. Rear Mounting Panel Cutout

data is listed in Table 2-5. The upper barrier strip is the digital strip and the signal data is listed in Table 2-6.

2-10. ANALOG CONNECTOR PIN DESCRIPTION. General descriptions of the signals provided at the analog connector are as follows:

a. Input High and Input Low. These are the signal input contacts. A positive voltage on input high relative to input low produces a positive display indication. Input low is transformer isolated from the power ground, the case, and (on Option A8) the digital ground. In this way, high common mode rejection and full flexibility in grounding is permitted.

b. Drive, Decimal 2, Decimal 3, Decimal 4, and Decimal 5. Connecting the desired decimal point contact to decimal point drive causes the corresponding decimal point in the display to be illuminated. Since AC drive is used, some care must be exercised in maintaining separation between these wires and the signal input. Decimal points 2 through 5 are numbered from right to left in the display with decimal 2 located to the left of the digit farthest to the right. With the TA 305 Series Panel Meters, only decimal points 3, 4, and 5 are active.

c. AC Power High, AC Power Low, Shield. The AC power input is applied between AC power high and AC power low. Consult the label (or decode the part number - refer to Section V) for correct voltage and frequency. The shield is normally connected to earth ground, however, common mode rejection may be improved by connecting the shield to the source of common mode voltage. The metal case is usually connected to earth ground, either through direct contact at the front panel mounting hardware, or through a solder lug under one of the rear panel self-tapping screws. However, common mode rejection can be improved by "floating" the case and tying it to a remote source of common mode voltage.

d. 5 VAC, 5 VAC C.T., Clock Serial BCD Out, Zero Volts, +15 Volts. These terminals are normally connected externally to the corresponding contacts on the digital (upper) connector when BCD output, Option A8 is specified. With this method there are no internal interboard connectors and isolated BCD output may be easily installed in the field at any time.

e. +5V, Power Ground. These two contacts are used for primary power input to units operating from a +5 VDC supply (Option A5).

f. Hold, Zero Volts. Normally, the meter will make repetitive readings at a rate of approximately 2 per second. If it is desired that a reading be retained in the display, the HOLD pin may be connected to zero volts through a switch or NPN transistor. After the HOLD signal is removed, a new reading will be initiated within 700 MS. The reading rate may be increased by a factor of 5 by connecting a 4.7 megohm resistor from the HOLD pin to the +15V pin. The unit will not make a reading while the HOLD signal is at the zero (short) level. To initiate a single reading, connect a 150K resistor from the HOLD pin (8) to +15V pin (P). The HOLD signal should go from 0 to 1 to 0 (short, open, short), remaining in the 1 state (open) for 7 MS.

g. All remaining pins are allocated for internal purposes, test functions, and other options, and therefore should not be used as tiepoints unless verified to be unused in a particular instrument.

2-11. DIGITAL CONNECTOR PIN DESCRIPTIONS (OPTION A8). All digital outputs are positive-true relative to the digital low signal and will drive one standard 7400 series TTL or DTL load. Descriptions of signals at the digital connector are as follows:

a. Binary Coded Decimal Signals. The BCD signal mnemonics are derived from the decade (10^0 through 10^4) and the binary weight (8, 4, 2, and 1) of the digit. The digital output of the instrument is standard and is utilized for a full 4-1/2 digit display with 10^0 assigned to the least significant and 10^4 to the most significant. The TA 305 Series Panel Meters, therefore, do not utilize the 10^0 output. The binary weight of the decade is determined by the decimal displayed. If decade 10^2 displays a numeral 9, outputs 8×10^2 and 1×10^2 are true (logical 1), 4×10^2 and 2×10^2 are false (logical 0).

b. Digital Low. With Option A8, all BCD outputs are relative to digital low. Since this contact is isolated from both input low and the power input, operation with remotely grounded data systems is possible without sacrificing common mode rejection.

c. Print. The positive print command output indicates that stable data is present in the output when it is positive. During data transfer this output goes false (logical 0) for approximately 40 μ S and returns to true (logical 1) approximately 1.6 μ S after the data transfer is complete, thereby eliminating any possibility of recording incorrect data. The negative print command is the complement of the positive output.

d. 5 VAC, 5 VAC C.T., Clock, Serial BCD, Zero Volts, +15 VDC. These terminals are normally connected to the analog connector of the instrument to provide power and signal inputs.

e. Overrange. The digital output of the shift register which, when true (logical 1), indicates that the instruments range has been exceeded.

f. + Polarity. The digital output of the shift register which indicates positive polarity of input when true (logical 1) and negative when false (logical 0).

g. All remaining pins are allocated for internal purposes, test functions, and other options, and therefore should not be used as tiepoints unless verified to be unused in a particular instrument.

Table 2-1. Standard Analog Connector (Lower)

Pin	Function	Pin	Function
*1	-7.5 V	A	Input High
2	Input High	B	Blank
3	Key	C	Key
4	Blank	*D	5 VAC
5	Blank	*E	5 VAC C.T.
6	Blank	*F	5 VAC
7	Blank	*H	Clock
8	Hold	J	Serial BCD Out
9	Decimal Point Drive	*K	10 ² 1
10	Input Low	*L	C2
11	Decimal 2	*M	+5 VDC
12	Decimal 3	N	Zero Volts
13	Decimal 4	*P	+15 Volts
14	Decimal 5	R	Shield Ground
15	AC Power High	S	AC Power Low (Power Ground)

*For Internal Use Only.

NOTE: Jumper pins H and L together on external connector for normal operation (no external linearization).

OBS



Table 2-2. Digital Connector (Option A8 Only) (Upper)

Pin	Function	Pin	Function
#1	BCD 4×10^0	#A	8×10^0
#2	BCD 1×10^0	#B	2×10^0
3	BCD 4×10^1	C	8×10^1
4	BCD 1×10^1	D	2×10^1
5	BCD 8×10^2	*E	5 VAC
6	BCD 4×10^2	*F	5 VAC C.T.
7	BCD 2×10^2	*H	5 VAC
8	BCD 1×10^2	J	Clock
9	BCD 8×10^3	K	Serial BCD
10	BCD 4×10^3	L	Blank
11	BCD 2×10^3	M	Blank
12	BCD 1×10^3	N	Blank
13	BCD 1×10^4	P	Zero Volts
14	Overrange	R	+15 Volts
15	+ Polarity	T	Blank
16	Print	T	Blank
17	Blank	**U	+5 VDC
18	Digital Low	V	Blank

*Used when basic instrument is provided with AC power supply.

**Used when basic instrument is provided with DC power supply.

#Not used.

Table 2-3. Digital-to-Analog Connector Pin External Jumpers (Option A8) With AC Power Supply

From Analog Connector	Function	To Digital Connector
D	5 VAC	E
E	5 VAC C.T.	F
F	5 VAC	H
H	Clock	J
J	Serial BCD	K
N	Zero Volts	P
P	+15 VDC	R

Table 2-4. Digital-to-Analog Connector Pin External Jumpers (Option A8) With +5 DC Power Supply (Option A5)

From Analog Connector	Function	To Digital Connector
-	+5 VDC Primary Power	U
H	Clock	J
J	Serial BCD	K
N	Zero Volts	P
P	+15 VDC	R

Table 2-5. Analog Barrier Terminal Strip Connections
(Option A10 Only) (Lower)

Terminal	Function
1	Input High
2	Hold
3	Decimal Point Drive
4	Input Low
5	Decimal Point 2
6	Decimal Point 3
7	Decimal Point 4
8	Decimal Point 5
9	AC Power High
10	Shield
11	AC Power Low

Table 2-6. Digital Barrier Strip Connections
(Options A8 and A10) (Upper)

Terminal	Function
1	BCD 8×10^1
2	BCD 2×10^1
3	BCD 4×10^1
4	BCD 1×10^1
5	BCD 8×10^2
6	BCD 4×10^2
7	BCD 2×10^2
8	BCD 1×10^2
9	BCD 8×10^3
10	BCD 4×10^3
11	BCD 2×10^3
12	BCD 1×10^3
13	BCD 1×10^4
14	Overrange
15	Polarity +
16	Print
17	Digital Ground

SECTION III THEORY OF OPERATION

3-1. GENERAL.

3-2. This section provides a description of the circuits contained in the basic instrument. Included are descriptions applicable to the optional power supplies and isolated parallel BCD output card.

3-3. FUNCTIONAL DESCRIPTION.

3-4. The TA 305 Series Digital Panel Meters utilize the unique Poly-Tektm method of analog-to-digital conversion. In operation, the input signal is scaled, buffered and applied to an integrator, the output of which feeds a comparator. When a given threshold is exceeded, the digital circuit causes a precise increment of charge to be fed to the integrator, thereby returning its output below the threshold. This process is allowed to continue for the first time interval of a measurement. During the second time interval, an interpolation method is used to supply the integrator the charge needed to return it to its starting level. Thus, the integrator is used as a highly-sensitive, charge-balance indicator. The digital circuitry is so arranged as to add counts to its output number in precise correspondence to the feedback charge. Thus, at the end of a reading, a number is transferred to the output storage which is accurately proportional to the average of the input signal. Since the measurement time interval has been chosen to be equal to two periods of the AC line frequency, this troublesome noise source is rejected by the converter to a high degree.

3-5. BASIC INSTRUMENT DESCRIPTION. The input signal is applied across the input high and input low terminals (Figures 3-1 and 3-2) and is supplied to plug-in range module A2. The range module contains the components required to scale the voltage or current input to a level compatible with integrated circuit input amplifier A5. Input amplifier A5 operates within a high gain feedback loop containing analog integrated circuit A6 and input range module A2. The range module functions to buffer the input circuit from the conversion circuitry. Amplifier A5 is a source of voltage gain to linearize the operation of analog integrated circuit A6. Analog integrated circuit A6 accepts the signal from input amplifier A5 and operates in conjunction with digital integrated circuit A8 to form an analog/digital feedback loop. At the conclusion of a reading, the result is transferred into digital storage within A8 which drives the display. Also, at this time the data appears as a serial pulse train which may be externally buffered for transmission (see Figure 3-7 for timing relationships). An optional internal serial-to-parallel converter (Option A8) can be provided which isolates this output and converts it to parallel TTL compatible levels along with a data ready signal. (Refer to paragraph 3-10.)

3-6. Digital integrated circuit A8 contains the reading rate and oscillator circuits, all counters, storage registers and digital logic to implement the Poly-Tektm conversion technique. In addition, it provides AC drive signals for the inputs to seven-segment, liquid-crystal display D1. The liquid-crystal display operates in the field-effect mode for high-contrast readings from a broad range of angles. It plugs into a special connector on the front of the printed circuit board.

3-7. EXTERNAL READ COMMAND. The external read command circuit (Figure 3-3) provides for precise time correlation of the measurement period with external events. When connected, this circuit inactivates the internal read rate generating circuit and provides for externally triggering the measurement period.

3-8. AC POWER SUPPLY. The power supply provided with the basic instrument operates on 117 VAC 60 Hz, 1.5 watts nominal. A schematic of the power supply is contained in Figure 3-4. The primary input power, protected by 1/8-ampere, fast-blow instrument fuse F1, is applied to transformer T1 which is shielded for isolation. The main secondary of T1 provides voltage conversion; the output of which is rectified, filtered, and regulated to produce +15 VDC, -15 VDC, and -7.5 VDC required by the circuitry. The tertiary winding provides a 5 VAC, 115 milliamperes for use by Option A8, Isolated Parallel BCD Output Card. The AC power supplies provided as Options A1 through A4 utilize similar circuitry with the exception of the transformer which is matched to the requirements of the primary input power.

3-9. DC POWER SUPPLY. The DC power supply provided as Option A5 (Figure 3-5) operates in similar manner to the AC supplies, except that the +5 VDC primary input power is converted by integrated circuit A9 to high-frequency AC before being applied to ferrite pot core transformer T1. The +5 VDC supply also has no 5 VAC secondary winding.

3-10. ISOLATED PARALLEL BCD OUTPUT OPTION A8. The isolated parallel BCD output card (Figure 3-6) is mounted within a basic instrument and is electrically connected to the basic instrument circuitry externally through the input/output connectors. Basic power for the supply is +15 VDC (pin R) and +5 VDC which is obtained either directly from a +5 VDC primary power source (pin U) or by rectifying and filtering 5 VAC power received from the basic unit AC power supply via pins E, F, and H. Timing for the BCD card is the 600 kHz (500 kHz if Option A6 is installed) clock received through pin J from the basic instrument circuitry. The serial data is applied to pin K (relative to pin P), buffered and transformer isolated, and gated into an integrated circuit shift register consisting of circuits Z1 through Z3 by IC flip-flop Z6A. The clock for the shift register is provided by IC flip-flop Z4A and IC gates Z5B and Z5C. Clearing of the shift register is accomplished by IC flip-flop Z6B and IC gates Z7E

and Z5A. The positive and negative print command outputs (pins T and 16) are provided by IC flip-flop Z4B. The BCD outputs of the shift register are relative to the digital low at pin 18.

3-11. ZERO AND COMPENSATION ASSEMBLY. Zero and compensation assembly A4 operates in conjunction with input amplifier A5 to provide for zero adjustment of the instrument. Two types of zero and compensation assemblies are utilized with the TA 305 Digital Panel Meter, depending on the type of input amplifier A5 that is used. If a type 308T input amplifier is used, zero and compensation assembly A4 as illustrated in Figure 3-8 is provided. If a type 725 input amplifier is used, zero and compensation assembly A4 as illustrated in Figure 3-9 is provided.

3-12. DIAGRAMS.

3-13. Figures 3-1 through 3-9 provide a block, schematics, and a timing diagram relative to the TA 305 Digital Panel Meter.



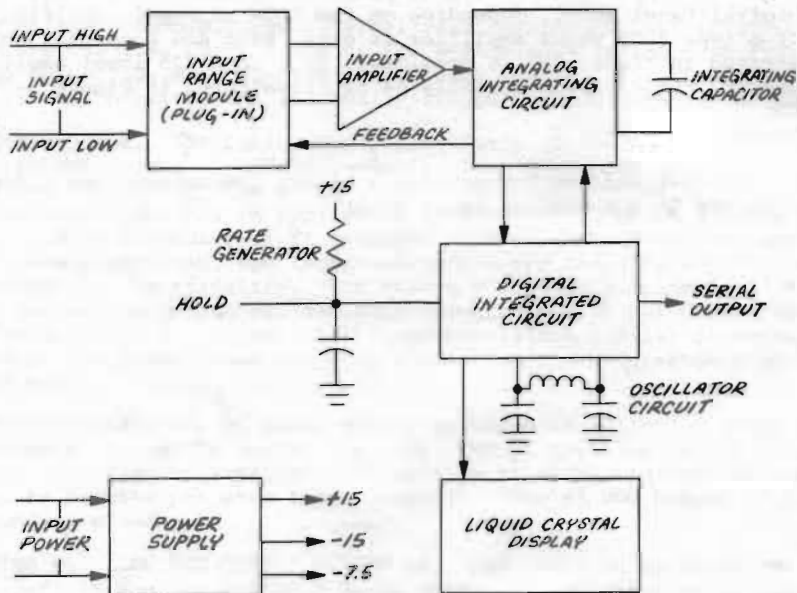

Figure 3-1. TA 305 Digital Panel Meter Block Diagram

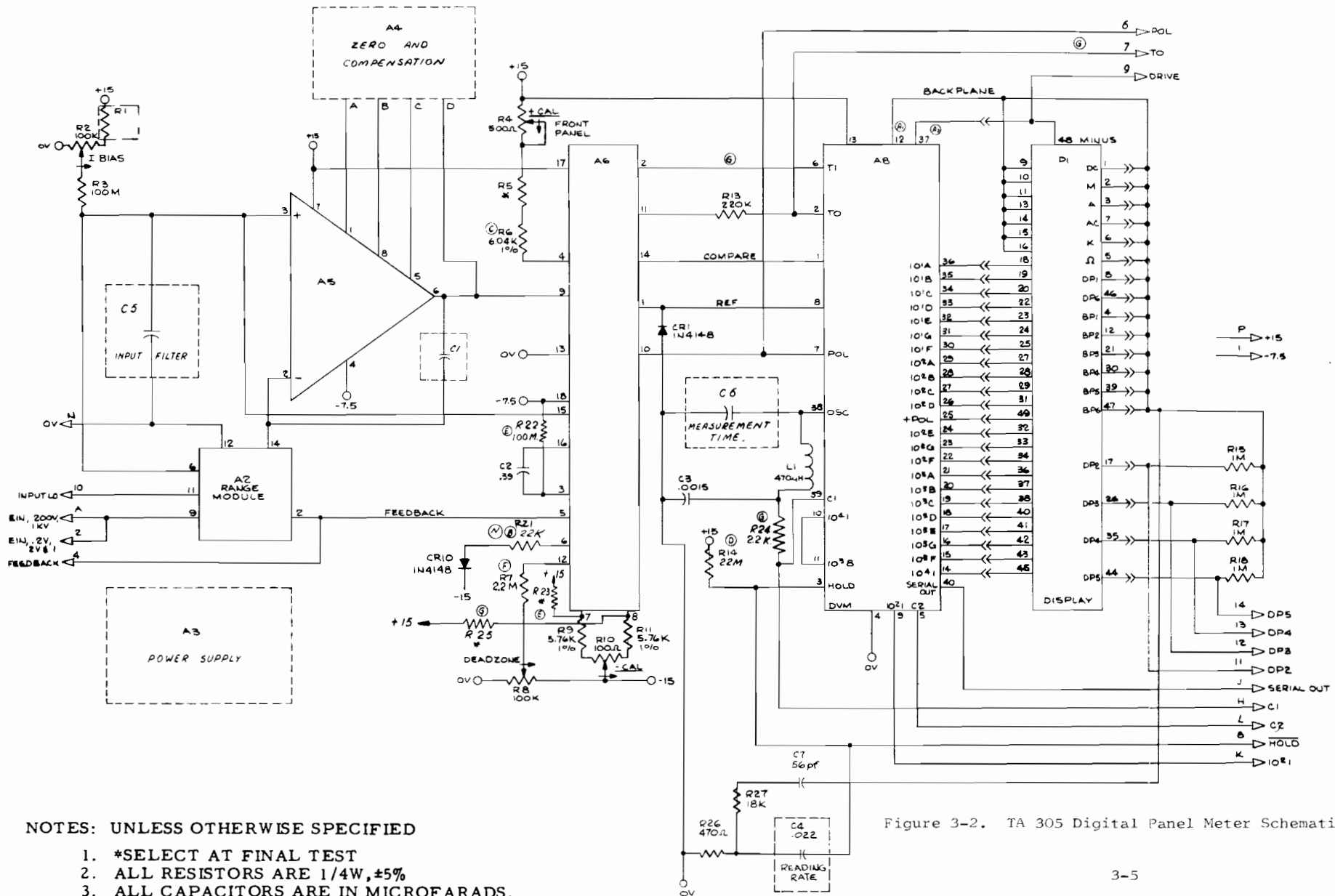
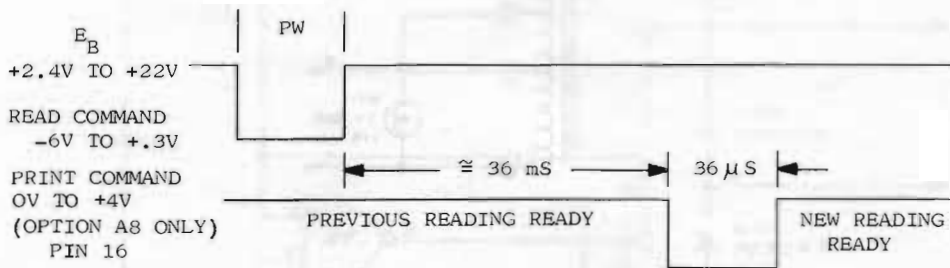
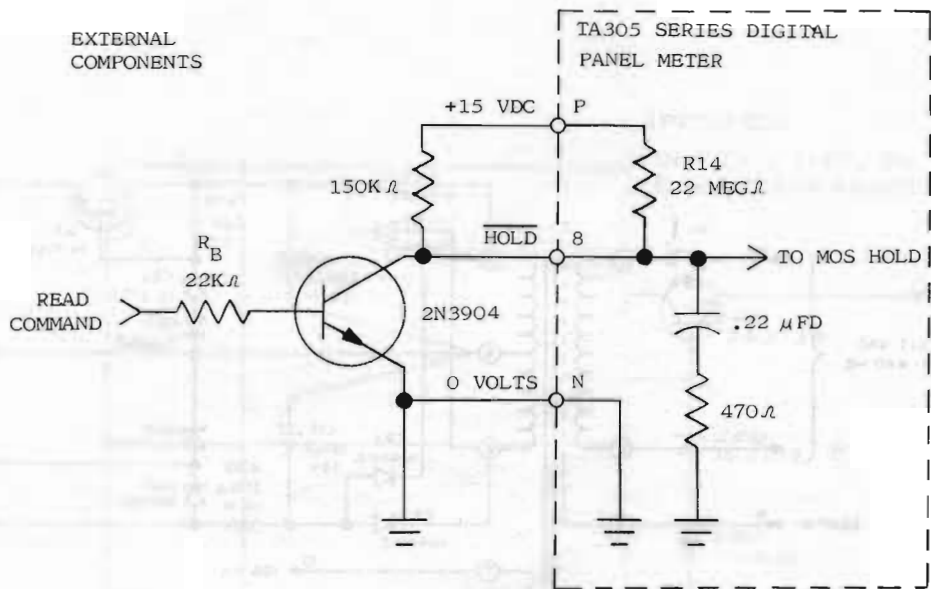

Figure 3-2. TA 305 Digital Panel Meter Schematic



NOTES:

1. $6 \text{ ms} < PW, \text{READ COMMAND} < 8 \text{ ms}$
2. R_B AND E_B ARE PROPER VALUE FOR DRIVING 2N3904 TRANSISTOR.

Figure 3-3. External Read Command Circuit Schematic

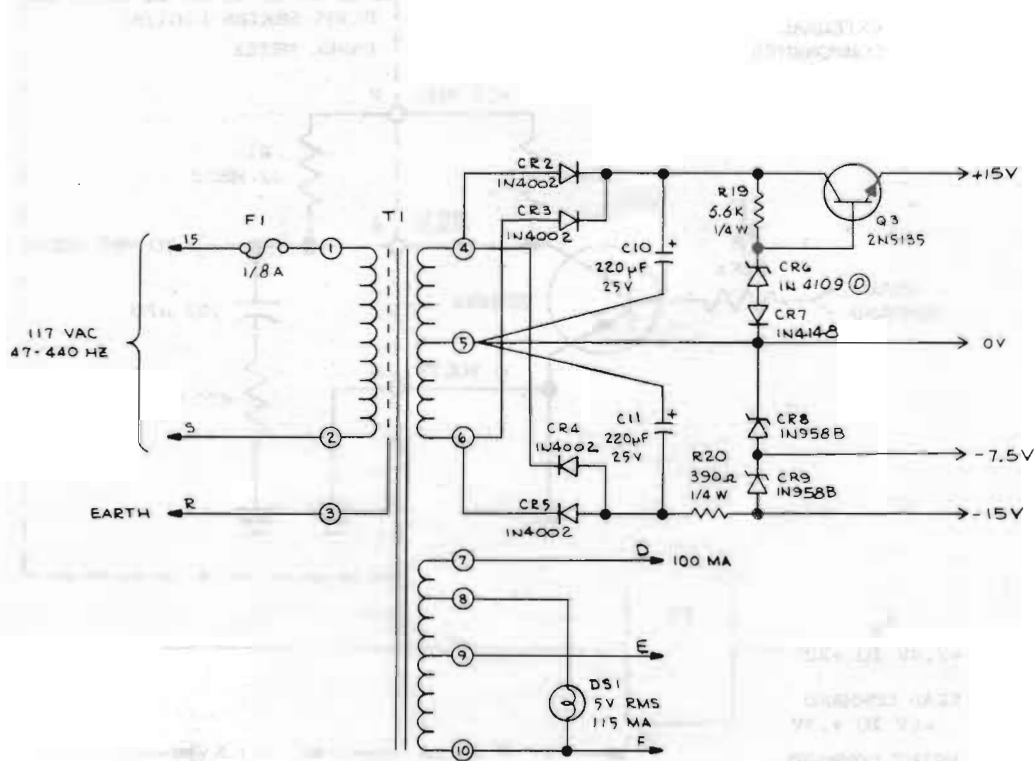
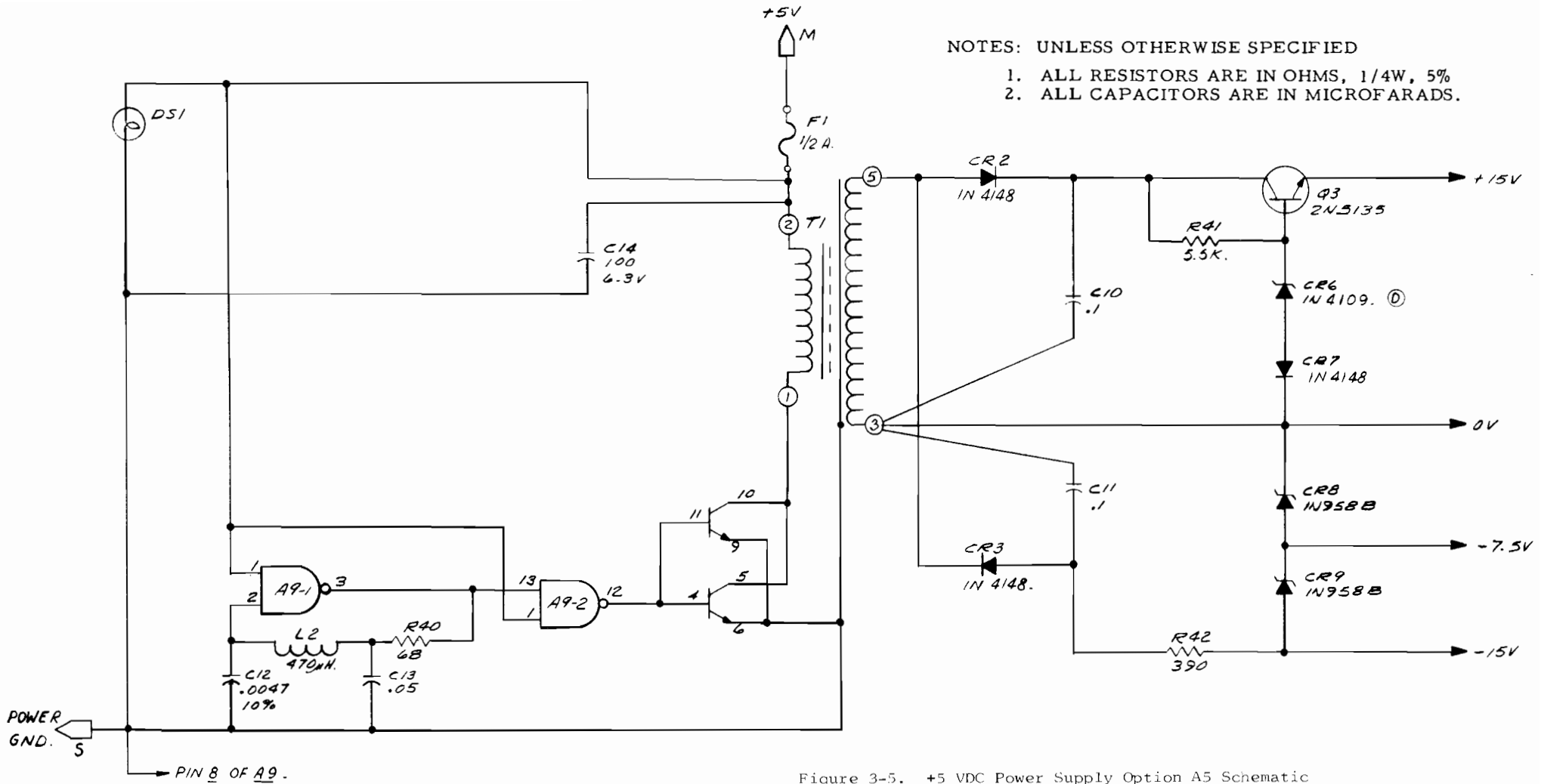

Figure 3-4. 117 VAC Power Supply Schematic



- NOTES: UNLESS OTHERWISE SPECIFIED
1. ALL RESISTORS ARE IN OHMS, 1/4W, 5%
 2. ALL CAPACITORS ARE IN MICROFARADS.

Figure 3-5. +5 VDC Power Supply Option A5 Schematic

NOTES: UNLESS OTHERWISE SPECIFIED

1. Z7A, Z7B, Z7C, Z7D, AND Z7E ARE PART OF INTEGRATED CIRCUIT Z7 (SN74LO4N)
2. Z5A, Z5B, AND Z5C ARE PART OF INTEGRATED CIRCUIT Z5 (SN74LOON)
3. ALL THESE TERMINALS TO HAVE WIRE SOLDER HOLES SPACED AT 0.100 INCHES, AS AN ACCESS FOR SPECTRA STRIP (10 WIRES #28 GAGE)
4. Z6A AND Z6B ARE PART OF ONE INTEGRATED CIRCUIT
5. Z4A AND Z4B ARE PART OF ONE INTEGRATED CIRCUIT
6. ALL RESISTORS ARE 1/4W, ±5%
7. BY-PASS CAPACITORS (C6, C7, C8, AND C9 ARE NOT SHOWN) LOCATED PHYSICALLY CLOSE TO EACH INTEGRATED CIRCUIT FROM +5V TO GROUND
8. 1 THROUGH 11 TERMINALS TERMINATE AT TOP OF BOARD ACCESS FOR SPECTRA STRIP (11 WIRES #28 GAGE)

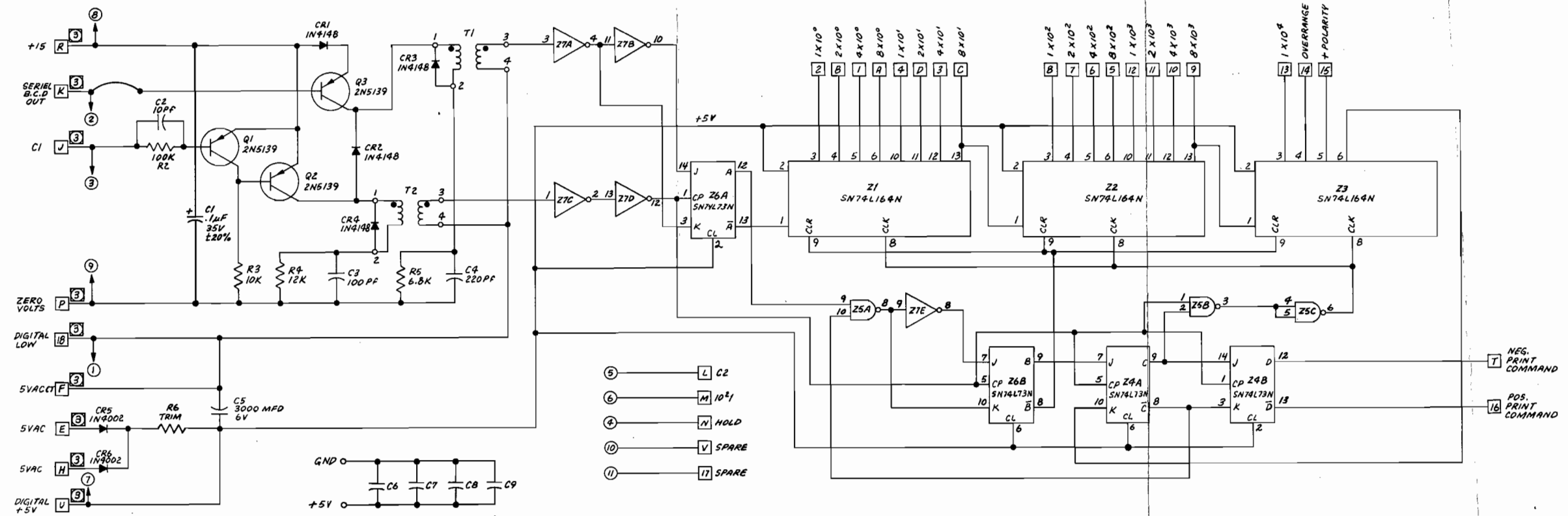

Figure 3-6. Isolated Parallel BCD Output Option AB Schematic

NOTES

1. RELATIVE TO +15V SUPPLY
2. RELATIVE TO 0V, ISOLATED SUPPLY
3. TA 310 4 $\frac{1}{2}$ DIGIT ALL DATA USED AS SHOWN
4. TA 305 3 $\frac{1}{2}$ DIGIT 10⁰ DIGIT RANDOM DATA - NOT USED
5. TA 300 2 $\frac{1}{2}$ DIGIT 10⁰ AND 10¹ DIGITS RANDOM DATA - NOT USED.
6. THESE OUTPUT WAVEFORMS ARE IDEALIZED AND BOTH CLOCK AND SERIAL OUTPUTS HAVE COMPLEX RISE TIMES (NOT SIMPLE TIME CONSTANTS) OF 150 TO 300 n SEC. THERE IS A DELAY OF APPROXIMATELY 500 TO 800 n SEC BETWEEN THE CLOCK EDGE INITIATING A PULSE IN THE SERIAL OUTPUT AND THE OCCURANCE OF THE SERIAL OUTPUT PULSE.
7. INTERFACE CIRCUIT CLOCK AND SERIAL OUTPUT.

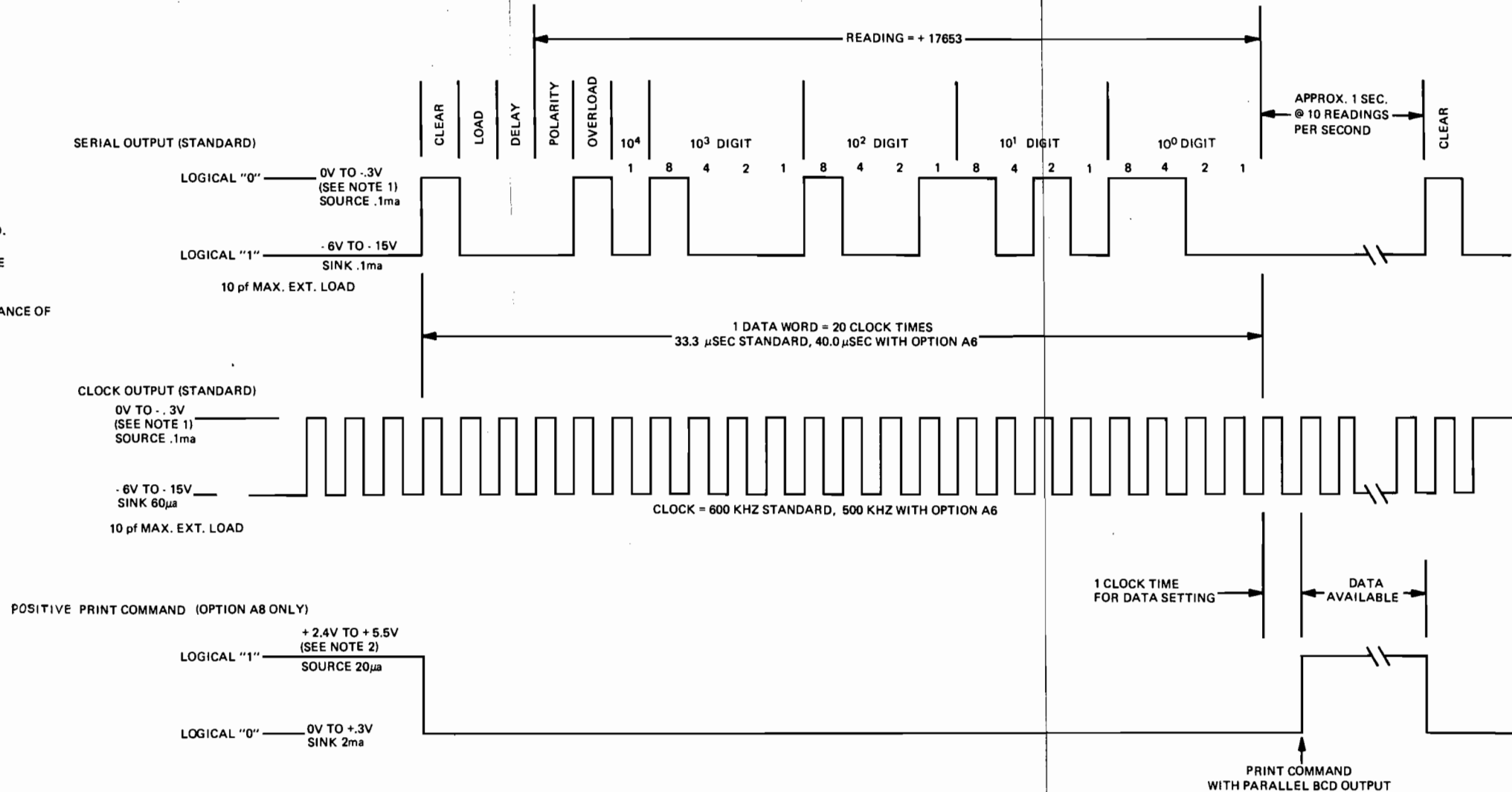
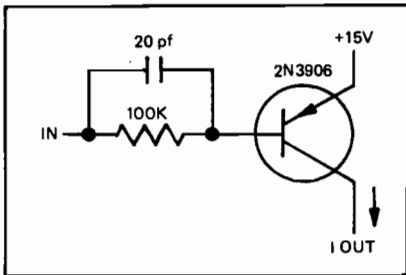

Figure 3-7. Serial BCD Output Timing Diagram

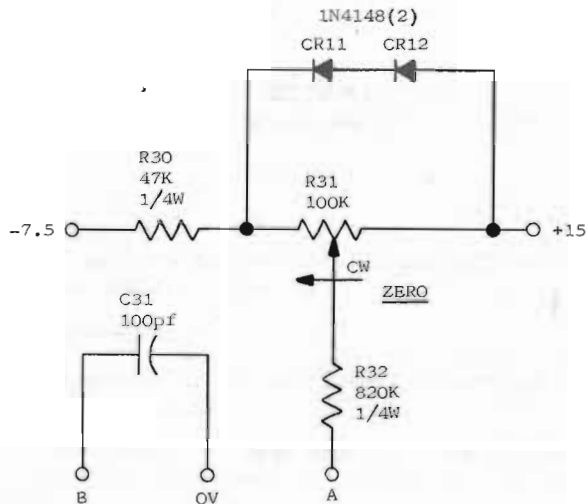

Figure 3-8. Zero and Compensation Assembly (Used With Type 308T Input Amplifier) Schematic

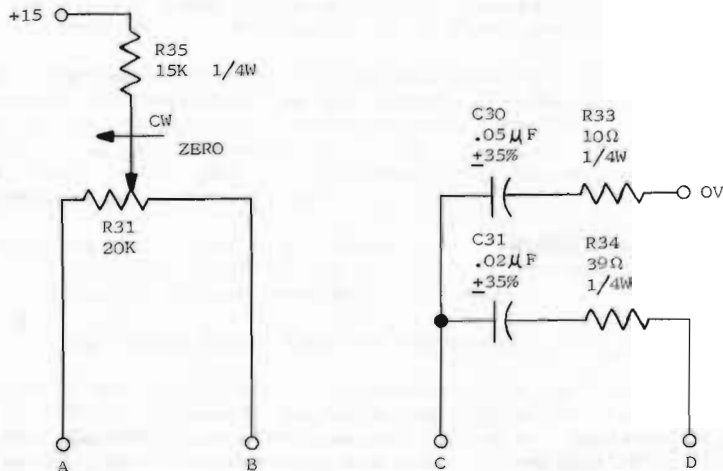

Figure 3-9. Zero and Compensation Assembly (Used With Type 725 Input Amplifier) Schematic

SECTION IV MAINTENANCE

4-1. GENERAL.

4-2. This section contains information for periodic maintenance, calibration, and general servicing instructions.

4-3. PERIODIC MAINTENANCE.

4-4. Periodic maintenance of the instrument is limited to cleaning and periodic adjustment.

4-5. CLEANING. The removal of dust and dirt from the instrument is to be accomplished as dictated by environmental conditions. To remove the instrument, proceed as follows:

a. Remove rear connector(s).

b. Remove snap-on plastic bezel (if present) by pulling gently outward on two indentations on its' lower surface. After removal, the ZERO and SPAN controls are accessible through the holes in the front panel for calibration.

c. The two front panel screws, located nearest the right and left edges of the panel, secure the instrument in the cutout. If the instrument is front mounted, turn these screws 5 or 6 turns counterclockwise to disengage the locking pawls, and slide the instrument out of the cutout. If the instrument is rear mounted, these two screws must be completely removed, or the nuts removed from the corresponding mounting studs.

d. To remove the instrument from the case, remove the four self-tapping screws securing the front panel to the extrusion. Two are located near the right edge of the panel and two near the left edge.

e. Slide the instrument forward out of the case.

4-6. Cleaning of the instrument is accomplished by removal of dust using compressed air (15 PSIG). Stubborn deposits are removed by brushing with a soft-bristled brush. Do not clean with chemical cleaners. Replacement of the instrument is accomplished by reversing the removal instructions.

4-7. PERIODIC ADJUSTMENT. The instrument has been carefully factory calibrated and stabilized using instruments traceable to the National Bureau of

Standards. Periodic adjustment is limited to adjustment of the ZERO and SPAN controls accessible through the front panel after the snap-on bezel is removed. Rear-mounted instruments will have to be removed from the panel unless access holes have been provided. To adjust the ZERO control, proceed as follows:

- a. Connect the signal for which a zero reading is required between input high and input low terminals.
- b. Adjust ZERO control (R31) for a reading of 0. (Note that this control has sufficient range to accommodate a substantial zero offset.)
- c. Apply an input for which a reading of 1900 is desired.
- d. Adjust SPAN control (R4) for 1900. The span control adjusts both polarities simultaneously. Any difference between negative and positive polarities exceeding the accuracy of the instrument indicates an incorrectly adjusted zero or the need for major calibration.

4-8. CALIBRATION.

4-9. Calibration of the instrument is accomplished on the test bench and should only be performed when the instrument exceeds the specified accuracy or after repairs are made. Calibration will also be required when changing range modules. The test equipment required for calibration (or the equivalent) is specified in Table 4-1. The instrument should be operated on the bench for fifteen minutes to stabilize prior to calibration. Calibration consists of the following adjustments; (1) input current zero, (2) zero adjustment, (3) dead-zone adjustment, (4) plus calibration, and (5) minus calibration. The locations of the adjustments are shown in Figure 4-1.

Table 4-1. Calibration Test Equipment

Test Equipment	Manufacturer
Differential Voltmeter	John Fluke Model 883
Voltage Standard	COHU Model 326
Oscilloscope	Tektronix Model 535 with type CA plug-in

4-10. INPUT CURRENT ZERO. To perform the input current zero adjustment, proceed as follows:

a. Connect 1 megohm resistor across differential voltmeter terminals and connect voltmeter across instruments input terminals.

b. Set differential voltmeter range to 1, null to 0.001, and reading to 000000.

c. Adjust R2 for null on differential voltmeter. If null cannot be obtained, perform plus calibration procedure contained in paragraph 4-13 and repeat this procedure.

4-11. ZERO ADJUST. To perform the zero adjust, proceed as follows:

a. Connect oscilloscope, set for 0.5 volts per centimeter, to pin 6 of differential amplifier assembly A5.

b. Jumper instrument input high to input low.

c. Adjust front panel ZERO control (R31) for zero volts as stable as possible.

4-12. DEADZONE ADJUSTMENT. The deadzone adjustment is performed as follows:

a. Using voltage standard, apply voltage to instruments input high and input low terminals equal to +20.5 digits.

b. Adjust R8 on instrument for indications of +20 and +20.5 (with equal frequency) on instrument.

c. Set input voltage to zero volts and observe that instrument indicates zero.

4-13. PLUS CALIBRATION. The plus calibration adjustment is performed as follows:

a. Using voltage standard, apply +1900 (+0.5) digits to instrument input high and input low terminals.

b. Adjust front panel SCALE control (R4) for indications of 1900 and 1901, with equal frequency.

4-14. MINUS CALIBRATION. The minus calibration adjustment is performed as follows:

a. Using voltage standard, apply -1900 (+0.5) digits to instrument input high and input low terminals.

b. Adjust R10 for indications of 1900 and 1901, with equal frequency.

4-15. SERVICING INSTRUCTIONS.

4-16. Nearly all circuit elements of the instrument are contained within integrated circuits, therefore high reliability and long life are expected. Any failure will usually require replacement of one of the integrated circuits; a process which should be performed at the factory or at a factory-authorized service center. If repair must be attempted, techniques and equipment available in qualified metrology shops can be implemented. Standard troubleshooting techniques and precautions relative to solid state devices and printed circuit boards should be followed. After any repair, calibrate the instrument following the instructions contained in paragraph 4-8. The location of replaceable parts in basic instrument is shown in Figure 4-1. Figure 4-2 contains a parts location diagram for the TA 305 with the +5 VDC power supply, Option A5, and figure 4-3 contains a parts location diagram for the isolated parallel BCD output board, Option A8. Replacement parts can be procured utilizing the information contained in Section III or by contacting your sales representative.

4-17. The following information is provided as aids to maintenance:

a. Power Fuse. Application of improper input power line voltage can blow the soldered-in fuse F1, located near the rear of the printed circuit board. If field replacement is required, care should be exercised in removing the blown fuse as an improper technique can result in permanent damage to the printed circuit board.

b. Display. If one or more display segments do not appear, it may indicate that extreme shock or vibration has caused the display to shift in its' socket. A careful sliding motion using the thumbs of both hands will return the display to its correct position at the far right side of the connector. CAUTION: The display is made of glass coated with special plastic films and excessive pressure can cause breakage.

c. Display Lamp. Instruments having transmissive displays incorporate an incandescent lamp soldered into the printed circuit board behind the display. Rated at 50,000 hour life, this lamp should seldom, if ever, require replacement. Therefore, correct input power and fuse integrity should be verified before attempting re-lamping. To replace this lamp, pull gently on leads to remove the glass bulb from the light bar. Note that a drop of silicon rubber retains the bulb and some moderate tension may be required. The leads should be unsoldered from the board and the new bulb installed. A drop of RTV silicon rubber on the back of the bulb is required to complete retention.

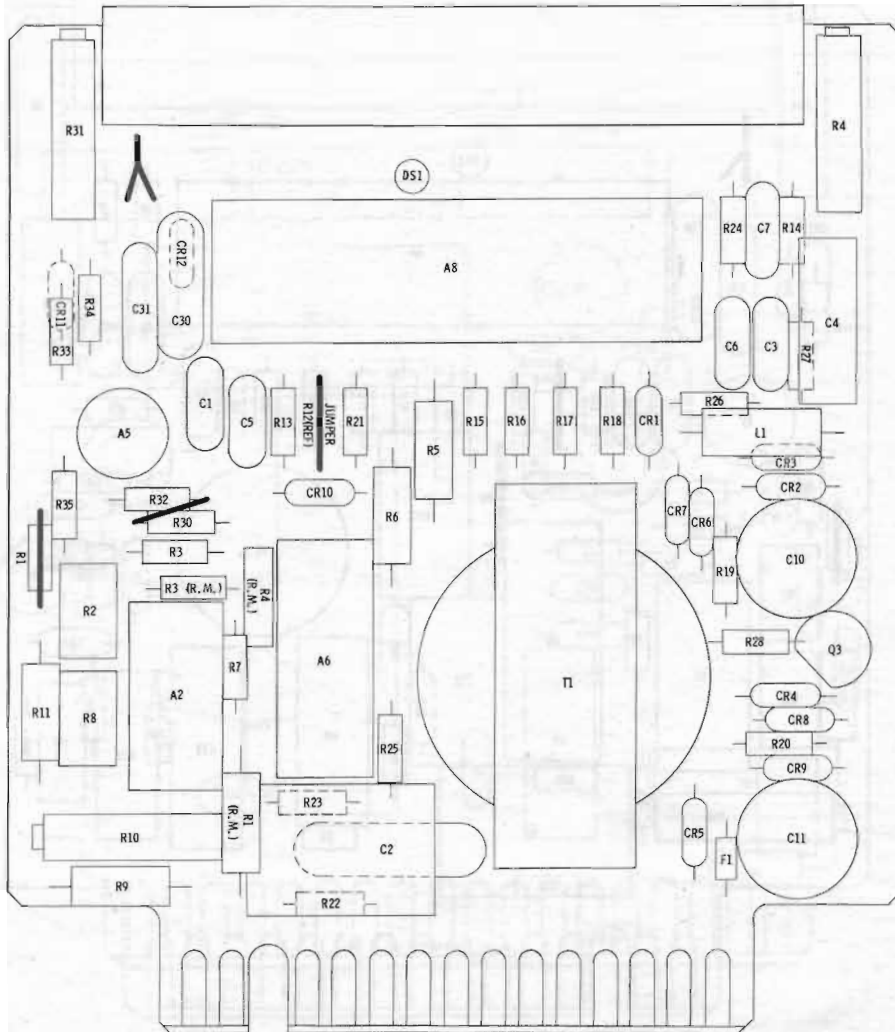

Figure 4-1. Basic TA 305 Parts Location Diagram

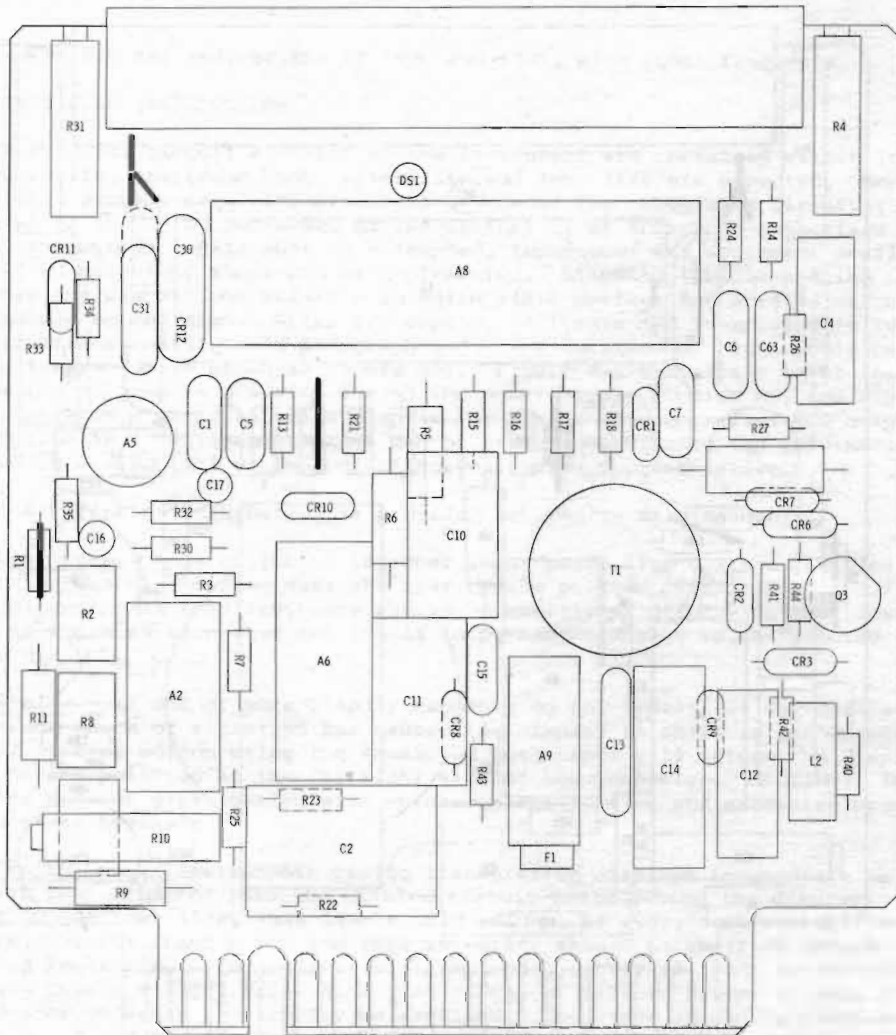

Figure 4-2. TA 305 With +5 VDC Power Supply (Option A5)
Parts Location Diagram

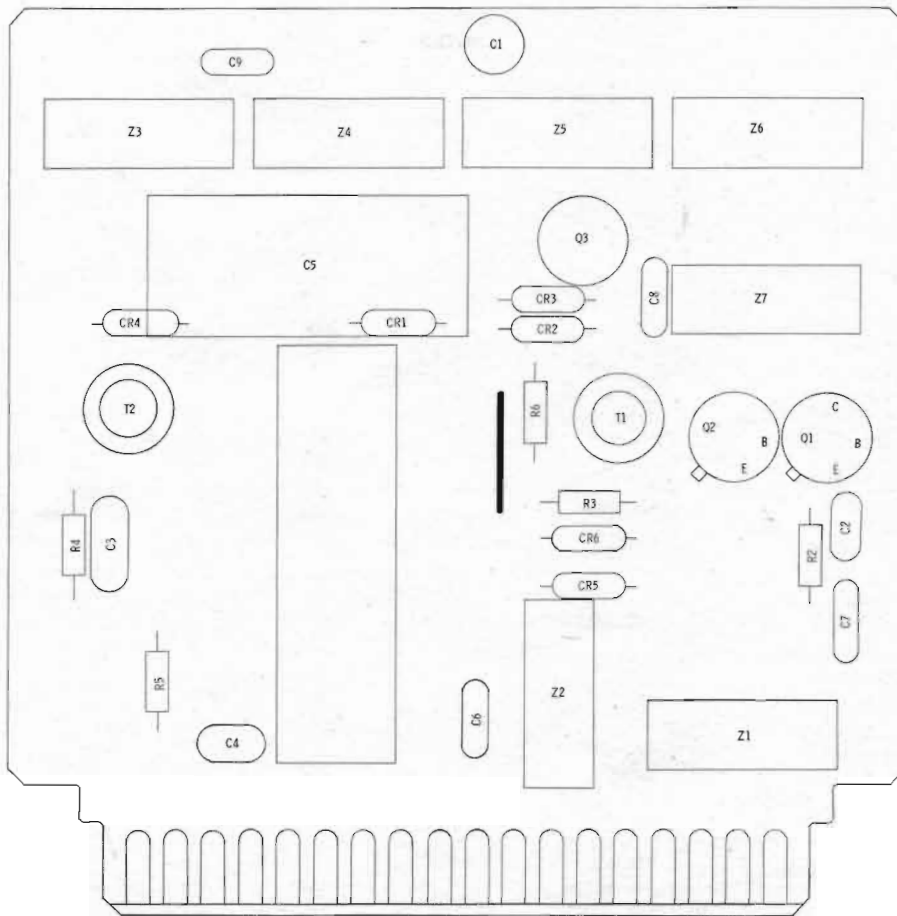

Figure 4-3. Isolated Parallel BCD Output (Option A8)
Parts Location Diagram

EQUIPMENT LOG

MODEL _____ RANGE _____

SERIAL NO. _____ DATE OF PURCHASE _____

OPTIONS: A1 A2 A3 A4 A5 A6 A7 A8
A9 A10 A11 A12 A13 A15 A16 A17 A18

CALIBRATION RECORD

1. _____ 2. _____ 3. _____
4. _____ 5. _____ 6. _____
7. _____ 8. _____ 9. _____

NOTES:



WARRANTY

TEKELEC warrants its products, when installed properly, to perform in accordance with all published specifications for one year from the date delivered.

TEKELEC will repair or replace products which prove to be defective during the warranty period provided they are returned prepaid to TEKELEC. Repaired products will be returned to the point of origin.

No other warranty is expressed or implied. TEKELEC is not liable for consequential damages.

TEKELEC, INC. TA

2623 SADDLE DRIVE
OXNARD, CA. 93030
CALL TOLL FREE (800)235-5951
IN CA. CALL (805)485-5445
TWX 910-336-1280